



## *Gestra® Steam Solutions Catalog*



*Experience In Motion*

## Contents

The Flowserve Gestra® Steam Trap Range	5	Operation	59
What Are Steam Traps?	5	UNA 14 and UNA 16	61
Short Guide to Steam Trap Selection	6	UNA 26H	63
Gestra Steam Traps, Liquid Drainers and Specialty Traps	7	UNA 26H MAX	65
Steam Traps MK	9	UNA 27H	67
Operation	9	UNA 38	69
Tandem seat	9	UNA Special Type 62	71
MK 36/A7	11	UNA Special PN 25	73
MK 35/31	13	Liquid Drainers - UNA	75
MK 35/32	15	UNA 14S and UNA 16S	77
MK 36/51 and MK 36/52	17	UNA 14P	79
MK 45/1	19	UNA 26H	81
MK 45/2	21	UNA 27H	83
MK 35/2S	23	UNA 38	85
MK 35/2S3	25	UNA 39	87
MK 25/2	27	UNA Special, Type 62	89
MK 25/2S	29	UNA PN 25 (2" and 2 ½")	91
TK 23 and TK 24 (2")	31	UNA PN 25 (3" and 4")	93
TK 23 and TK 24 (2½", 3" and 4")	33	UNA Special PN 63	95
Steam Traps BK	35	DK 36/A7	97
Operation	35	DK 47	99
BK 36/A7	37	DK 57	101
BK 45	39	AK 45	103
BK 46	41	SMK 22	105
BK 37	43	GK 11/21	107
BK 28	45	UBK 46	109
BK 29	47	Check Valves	111
BK 212	49	MB 26A	113
BK 212HT	51	RK 70 and RK 71	115
BK 212EX	53	RK 41	117
BK 15	55	RK 44 and RK 44S	119
BK 27	57	RK 16	121
Ball Float Traps – UNA	59	RK 26A	123
		RK 86 and RK 86A	125

## Contents continued

RK 76	127
RK 49	129
CB 14	131
CB 24S, CB 26, CB 26A	133
Special Equipment and Vessels for Heat Recovery	135
FPS-11	137
FPS-14	139
FPS-24	141
FPS-33L	143
Skid Packages	145
V20	147
FMAVC	149
FMAVS	151
FMAHC	153
FMAHS	155
Gestra Engineering Table	157
Steam Table	159
Electronics	
Level Control	
NRGS 11-1, NRGS 16-1, NRGS 16-1S	161
NRGS 11-2, NRGS 16-2	163
NRGS 15-1	165
NRG 16-42	167
NRS 1-42	169
NRS 1-3	171
NRS 1-5	173
NRGT 26-1, NRGT 26-1S	175
NRS 2-3	177
NRG 26-40	179
NRS 2-40	181
NRR 2-40	183
NRG 21-11, NRG 21-51	185
NRG 26-21	187
NRZ 2-1	189

NRS 2-1	191
NRG 16-11, NRG 17-11, NRG 19-11	193
NRS 1-7	197
NRS 1-8	199
NRG 16-36	201
NRS 1-9	203
NRG 16-41, NRG 17-41, NRG 19-41	205
NRG 16-40, NRG 17-40, NRG 19-40	207
NRG 211	209
NRS 2-4	211
NRS 2-5	213
NRS 1-40	215
NRS 1-41	217
Conductivity Measurement	
LRGT 16-1	219
LRG 16-40	221
LRG 16	223
LRG 17, LRG 19	227
LRS 1-5B, LRS 1-6B	229
LRG 12-2	231
LRG 12-1	233
LRT 1-5B, LRT 1-6B	235
LRR 1-40	237
Control Valves	
ZK 29	239
ZK 313	243
ZK 213	247
BA(E) 46, BA(E) 47	251
BA 28, BA 29, BA 210, BA 211	257
(M)PA 46, (M)PA 47, (M)PA 110	259
Turbidity Monitoring	
ORGS 11-2	263
OR 52/5, OR 52/6	265
Controllers and Misc. Electronics	



## The Flowserve Gestra® steam trap range

### What are steam traps?

To be able to operate a plant over a long period with an optimum efficiency, the choice of the correct valves is of vital importance.

Among these valves are steam traps, which have an important role to play. Steam must be trapped within heating equipment until it has surrendered all heat energy, at which point the condensate formed must be immediately discharged.

### The three steam trap types

#### BK

The BK is a thermostatic steam trap with Duo stainless (bimetallic) regulator.

Advantage: particularly robust.

#### MK

The MK is a thermostatic steam trap with membrane regulator.

Advantage: very sensitive response characteristic.

#### UNA

The UNA is a float trap.

Advantage: condensate discharge at extreme and sudden condensate flowrate and pressure fluctuations.

The optimum efficiency of a steam-heated plant is dependent upon the performance of steam traps.

One type of steam trap cannot be equally well suited for the various applications and requirements. Therefore, Flowserve

Gestra offers a comprehensive steam trap range developed and refined on practical applications over the years.

The choice of the steam trap type depends, of course, on the plant condition. We are willingly prepared to assist you in selecting the most economic solution for your particular application.

### What are the advantages of Flowserve Gestra steam traps?

- Easy maintenance – our traps can be checked, cleaned and repaired without being removed from the pipeline.
- Interchangeable – our various trap types have standardized face-to-face dimensions, sizes and end connections and are therefore interchangeable without any modification to the pipe layout.
- Tight shut-off, without loss of live steam.
- Automatic air-venting.
- Unaffected by dirt.
- Production tested – besides the legally required tests (e.g., hydraulic test), our trap regulators are tested under operating conditions (steam, condensate).
- Complies with recognized standards – our traps meet the relevant DIN standards and regulations, and are in accordance with the AD bulletins (AD - Arbeitsgemeinschaft Druckbehälter = German pressure vessel regulations authority) with regard to choice of material, pressure and temperature ratings. On request test certificates to EN 10204.



## Short guide to steam trap selection

Not all steam trap types are equally suitable for a given application. Depending on the operating conditions and service in question, one or more systems will be particularly well suited.

The following table contains 14 criteria for steam trap selection based on the operation of the plant and the specific requirements on the part of the plant owner.

Criteria		Steam trap types				Please note:
		Trap type BK with bimetallic regulator	Trap type MK with bimetallic regulator	Ball Float type UNA with Duplex control	Ball Float type UNA with Simplex control	
1. Operation with different condensates	Condensate from steam	1	1	1	1	For "cold" condensates or condensates with a saturation curve deviating from that of water only float traps featuring Simplex control (without thermal venting) can be used.
	Condensate from compressed air	—	—	—	1	
	Condensate, distillate from chemical products	—	—	—	1	
2. Different modes of operation	Continuous operation: Constant formation of condensate; flowrate and pressure vary	2	1	1	1	
	Discontinuous operation: Intermittent formation of condensate; flowrate and pressure vary strongly	2	1	1	3*	* e.g. air venting difficulties
	Any operation: Heat exchanger may be controlled on the steam side	3**	2	1	3*	* Air venting difficulties ** With partial load (reduced differential pressure) flowrate possibly not sufficient
3. Operation with back pressure	Up to approx. 30% of upstream pressure	1	1	1	1	
	> 30% of upstream pressure	3	1	1	1	
4. Sensitivity to dirt	Highly contaminated condensate	1	1	1	1	
5. Air-venting	Automatic	1	1	1	3*	* Manual air-venting
6. Condensate discharge at definite temperatures	Condensate temperature nearly boiling temperature	3	2*	1	1	This may apply to small heat exchangers (e.g. laboratory equipment) * Might require special membrane regulator
	Condensate undercooling approx. 54°C (required)	1*	1**	—	—	* with U-type regulator ** with U-type capsule
	Condensate undercooling adjustable	3*	—	1	1	* If possible use steam trap with adjustable discharge temperature UBK
7. Frost resistance		1	1	1*	3*	* Only ensured with V-type design
8. Condensate discharge without loss of live steam	Intermittent condensate formation	1	1	1	1	
	Reduced condensate formation (< 22 lb/h)	1	1	1	1	
	Continuous condensate formation (> 22 lb/h)	1	1	1	1	
9. Resistance to waterhammer		1	1*	3	3	* Built-in non-return valve
10. Non-return valve action		1	1*	—	—	* Built-in non-return valve
11. Application in vacuum		3	2	1	1	
12. Installation in any position		1	1	—	—	
13. Easy of maintenance		1	1	1	1	
14. Service life of control unit		1	2	1	1	

### Ratings:

- 1 = Excellent
- 2 = Good
- 3 = Fair or Conditional
- = Not recommended

## ***Gestra Steam Traps, Liquid Drainers and Specialty Traps***

**For Drip and Tracer, High Pressure and Process Applications**



---

This page intentionally left blank.



## Steam Traps MK

**Thermostatic steam traps with membrane regulator. Pressure ratings up to ANSI 600. Unexcelled regulating accuracy due to thermostatic capsule.**

**May also be used for thermal air-venting.**

**With Tandem seat (double sealing) for low condensate flowrates.**

**For larger condensate flow rates with single seat.**

The main feature of the MK traps is an unusually sensitive response. They are particularly suited for the drainage of such heat exchangers that would be appreciably affected in their operation by even the slightest banking-up of condensate. The operation of the trap is influenced neither by its position of installation nor by upstream or back pressure.

The thermostatic capsule and all other internals are made of corrosion-resistant materials. The membrane of Hastelloy® is completely corrosion-resistant, even with acid condensate and condensate containing chlorides.

Two different designs of the thermostatic capsule are available:

- standard capsule (N) for instantaneous condensate discharge without any banking-up. Opening temperature approximately 18°F (10°C) below saturation temperature.
- undercooling capsule (U) for additional energy savings (utilization of a certain amount of sensible heat by banking-up of condensate, thus decreasing the amount of flash steam). Opening temperature approximately 54°F (30°C) below saturation temperature. The integral non-return valve with hollow cone and reduced mass protects the capsule from waterhammer. The asbestos-free cover gasket is maintenance-free. The large-surface strainer protects the trap from dirt, ensuring longer maintenance intervals. For particularly aggressive condensate and special hygienic requirements, the MK 45 A is available made completely of stainless steel.



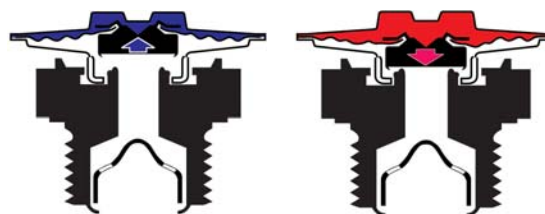
### Operation

#### Membrane regulator

**Opening** The capsule of the membrane regulator is filled with a liquid having an evaporation temperature that is just a few degrees below the saturation temperature of water. During shut-down or start-up of the plant (i.e., if cold condensate is present), the liquid filling is completely condensed. The pressure in the capsule is lower than the surrounding pressure (service pressure); the membrane with the valve disc is pushed in the opening direction.

**Closing** With rising condensate temperature, the liquid filling starts to evaporate. The pressure in the capsule

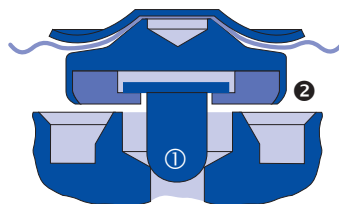
rises; the membrane with the valve disc is moved in the closing direction. Just before the condensate has reached its saturation temperature, the trap is closed completely.



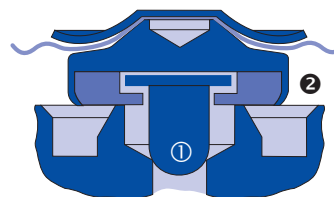
#### Tandem seat

The self-centering valve cone 1 ensures steam-tight closure. With rising temperatures the additional flat seat 2 closes too and provides a further guarantee of tightness, even in the presence of dirt particles. Moreover, the pressure drop in two stages across the orifice area of the trap reduces wear and enhances the life of the trap.

**During plant operation**  
Seat 1 closes (regulator is pushed in the closed position).



**Trap closed**  
Both seats are tightly shut off.



**Rhombus-shaped cover**  
secured with only two bolts, which are easy to insert and easy to use in restricted spaces.

**Thermostatic capsule**  
Regulator unit replaceable without removing body from pipeline. Precise reaction to any change in temperature. Corrugated membrane of Hastelloy®. High elasticity, long service life.

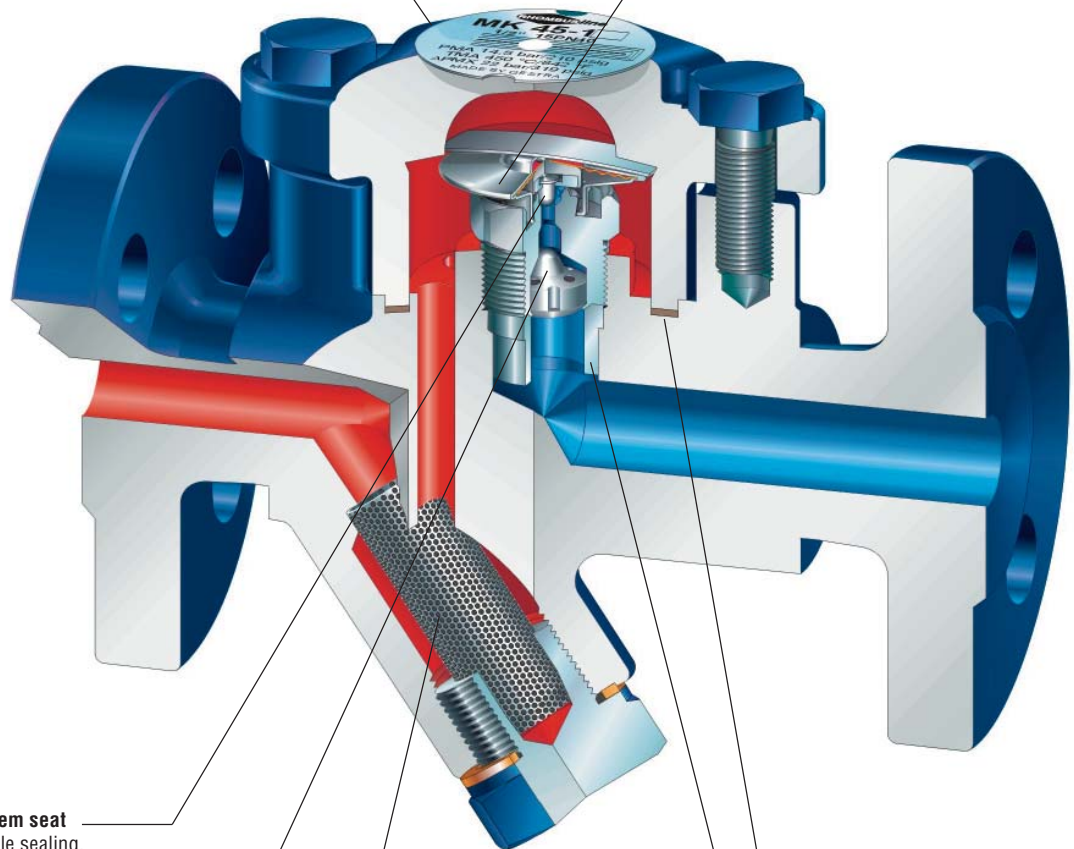
**Tandem seat**  
Double sealing.

**Non-return valve with hollow cone and reduced mass**  
Quick closing in the event of waterhammer.

**Large-surface strainer**

**Recessed flat gasket for superior sealing**

**Metal base bushing**



# Gestra® Steam Trap • Thermostatic Steam Trap

**MK 36/A7**

465

psi  
Maximum Δp  
(32 bar)

**Class Rating:** ANSI 300

**Available Sizes:** 1/2", 3/4" and 1"  
(DN 15, 20 and 25)

**Application**

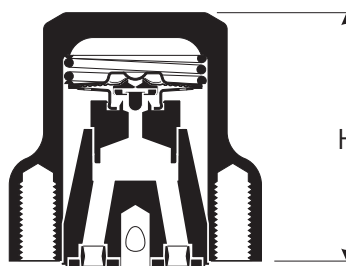
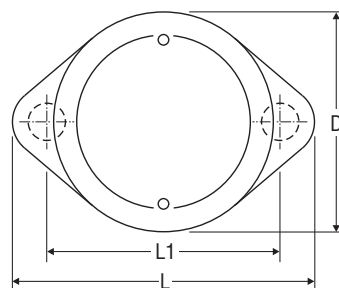
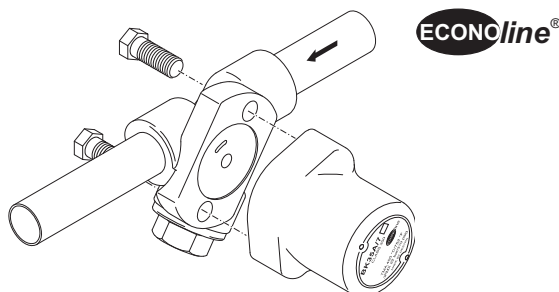
The **ECONOLine**® MK 35/A7 steam trap is used for low capacity applications such as drip and tracing. The trap is attached to the universal connector by means of 2 hex head bolts and can be used on any existing connectors in your piping system.

**Features and Benefits**

- Tandem seated control capsule combined with a venturi-style orifice uses a unique double valve and seat for tight shutoff, cyclical discharge and superior dirt-handling ability.
- Discharges hot condensate at approximately **18°F (10°C)** below saturation temperature throughout its operating range. One internal regulator for all pressure ranges.
- Cyclical discharge eases audible/visual performance checking.
- Resistant to water hammer.
- Self-draining – will not freeze when installed in gravity drainage position.
- Automatically vents air and non-condensable gases and has a high **(4:1)** cold water capacity for rapid startup.
- Operates with **zero steam loss** throughout its operating range, saving steam and money during the life of the trap.
- Can be installed in any position.
- Two (2) year guarantee.

**Materials**

- Cover – A351-CF8M (DIN 1.4408)
- Cover Bolts – ASTM A193-B7 (DIN 1.7225)
- Regulator – Hastelloy® and Stainless Steel
- Other Internals – Stainless Steel
- Connector – A351-CF8M (DIN 1.4408)



Dimensions and Weights		End Connections		
		Screwed / Socket Weld		
Nominal Sizes	[inch] [mm]	<b>1/2</b> 15	<b>3/4</b> 20	<b>1</b> 25
Dimensions	D [inch] [mm]	<b>1.9</b> 49		
	L [inch] [mm]	<b>2.6</b> 66		
	L1 [inch] [mm]	<b>2.0</b> 51		
	H [inch] [mm]	<b>2.6</b> 65		
Approx. Weight w/o connector	[lbs]	<b>1.5</b>		
	[kg]	0.7		
Approx. Weight with connector	[lbs]	<b>4.2</b>	<b>4.0</b>	<b>3.7</b>
	[kg]	1.9	1.8	1.7

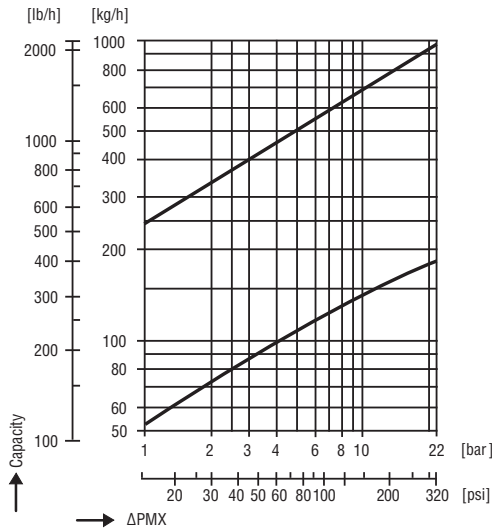
**465**  
psi  
Maximum  $\Delta p$   
(32 bar)

**Gestra® Steam Trap •  
Thermostatic Steam Trap**

**MK 36/A7**

**Class Rating:** ANSI 300

**Available Sizes:** ½", ¾" and 1"  
(DN 15, 20 and 25)



**Capacity Charts**

The chart shows the maximum capacities for hot and cold condensate. The capacities are a function of differential pressure or the difference between inlet and outlet pressures for the trap.

Curve 1 shows the maximum capacity when discharging hot condensate that is **18°F (10°C)** below steam saturation temperature. For example, at a differential pressure of **100 psi** the maximum hot capacity is approximately **250 lb/h**.

Curve 2 shows the maximum capacity when discharging cold condensate at a temperature of **68°F (20°C)**. For example, at a differential pressure of **100 psi** the maximum cold capacity is approximately **1,100 lb/h**.

**Available End Connections**

Screwed sockets: NPT, BSP

Socket-weld

Butt weld

**How to Order**

For the trap only:

MK 35/A7

For the trap and connector:

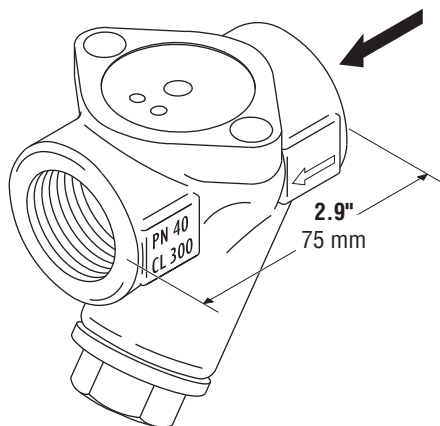
Specify trap, end connection size and type.

For Example: MK 35/A7 ½" NPT.

Add "w/BOV" if blow-off valve is desired.

Pressure/Temperature Ratings						
Maximum Service Pressure	[psig]	<b>719</b>	<b>613</b>	<b>519</b>	<b>458</b>	<b>421</b>
	[barg]	49.6	42.3	35.8	31.6	29
Related Temperature	[°F]	<b>68</b>	<b>212</b>	<b>392</b>	<b>572</b>	<b>842</b>
	[°C]	20	100	200	300	450
Maximum Differential Pressure		<b>320 psig (22 barg)</b>				

Flowserve Gestra Universal Connector



# Gestra® Steam Trap • Thermostatic Steam Trap

**MK 35/31**

**305**  
psi  
Maximum Δp  
(21 bar)

**Class Rating:** ANSI 300

**Available Sizes:** 3/8" and 1/2"  
(DN 10 and 15)

**Application**

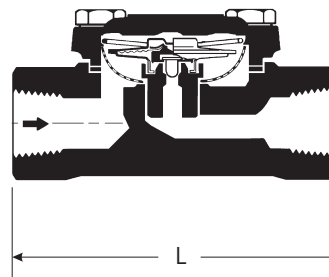
The MK 35/31 steam trap is used for lower-capacity applications such as drips, tracers and light process where only saturated steam is used. The trap features a replaceable capsule with tandem seated design.

**Features and Benefits**

- Control capsule of Hastelloy® and Stainless Steel for superior corrosion resistance.
- Tandem seated control capsule combined with a venturi style orifice uses a unique double valve and seat for tight shutoff, cyclical discharge and superior dirt-handling ability.
- Forged Steel Body and Cover.
- Standard (N) capsule discharges hot condensate at approximately **18°F** (10°C) below saturation temperature throughout its operating range. One internal regulator for all pressure ranges.
- Resistant to water hammer.
- Self-draining – will not freeze when installed in gravity drainage position.
- Automatically vents air and non-condensable gases and has a high (>**3:1**) cold water capacity for rapid start-up.
- Operates with **zero steam loss** throughout its operating range, saving steam and money during the life of the trap.
- Can be installed in any position.
- Small profile and lightweight for ease of use and maintenance.
- Internal stainless steel strainer.
- Three (3) year guarantee.

**Materials**

- Body and Cover – ASTM A105 (DIN 1.0460)
- Regulator – Hastelloy® and Stainless Steel
- Other Internals – Stainless Steel



Pressure / Temperature Ratings				
Maximum Service Pressure	[psig]	<b>305</b>	<b>189</b>	<b>131</b>
	[barg]	21	13	9
Related Temperature	[°F]	<b>437</b>	<b>752</b>	<b>842</b>
	[°C]	225	400	450
Maximum Differential Pressure	305 psi (21 bar)			

Dimensions and Weights		End Connections	
		Screwed / Socketweld	
Nominal Sizes	[inch]	<b>3/8</b>	<b>1/2</b>
	[mm]	10	15
Dimensions	L [inch]	<b>3.7</b>	<b>3.7</b>
	[mm]	95	95
Approx. Weight	[lbs]	<b>1.5</b>	<b>1.8</b>
	[kg]	0.7	0.8

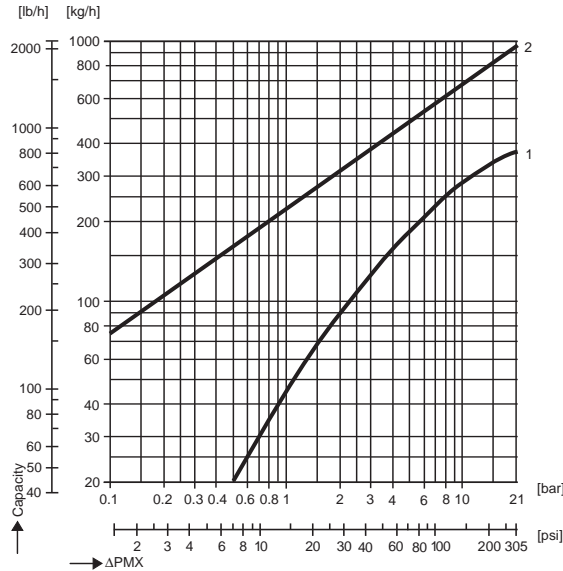
**305**  
psi  
Maximum  $\Delta p$   
(21 bar)

**Gestra® Steam Trap •  
Thermostatic Steam Trap**

**MK 35/31**

**Class Rating:** ANSI 300

**Available Sizes:** 3/8" and 1/2"  
(DN 10 and 15)



**Capacity Charts**

The charts show the maximum capacity for hot and cold condensate. The capacities are a function of differential pressure or the difference between inlet and outlet pressures for the trap.

Curve 1 shows the maximum capacity when discharging hot condensate that is **18°F (10°C)** below steam saturation temperature. For example, at a differential pressure of **100 psi**, the maximum hot capacity is approximately **500 lb/h**.

Curve 2 shows the maximum capacity when discharging cold condensate at a temperature of **68°F (20°C)**. For example, at a differential pressure of **100 psi**, the maximum cold capacity is approximately **1,200 lb/h**.

**Temperature Discharge Options**

The MK 35/31 steam trap is available with an optional undercooling capsule (**U**) for open discharge applications where sensible heat savings and flash steam suppression are desirable. This capsule discharges condensate at **54°F (30°C)** below saturation temperatures. Please contact your local Flowserve Gestra representative for details.

**Body Pressure/Temperature Rating**

The chart shows the maximum shell (body) pressure and temperature rating. Regulator operating differential pressure is limited to **305 psi**.

**Material/Test Certificates**

All inspection requirements must be stated at time of order. Test certificates can be issued on request in accordance with EN 10204 – 2.2 and -3.1B. Body and Cover heat codes are required.

**Available End Connections**

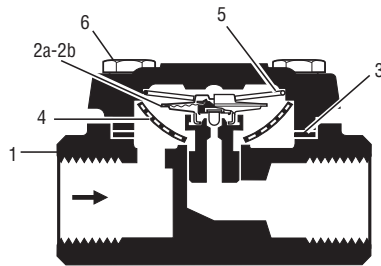
NPT, BSP

SW

**How to Order**

Specify trap, end connection size and type.

For Example: MK 35/31 1/2" (N) NPT



Standard Spare Parts		
Item Number	Description	MK 35/31
1	Body & Cover	
2a	Capsule (5N1)	376165
2b	Capsule (5U1)	376166
3	Cover Gasket	087080
4	Strainer	087401
5	Retaining Spring	098317

# Gestra® Steam Trap • Thermostatic Steam Trap

**MK 35/32**

305

psi  
Maximum Δp  
(21 bar)

**Class Rating:** ANSI 300

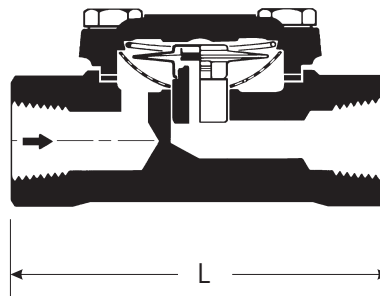
**Available Sizes:** 3/8" and 1/2"  
(DN 10 and 15)

**Application**

The MK 35/32 steam traps is used for higher-capacity applications such as drips, tracers and light process where only saturated steam is used. The trap features a replaceable capsule with single seated design.

**Features and Benefits**

- Control capsule of Hastelloy® and Stainless Steel for superior corrosion resistance.
- Flat seated capsule for modulating discharge. Discharges condensate at the rate it is presented to the trap.
- Forged Steel Body and Cover.
- Standard (N) capsule discharges hot condensate at approximately **18°F** (10°C) below saturation temperature throughout its operating range. One internal regulator for all pressure ranges.
- Resistant to water hammer.
- Self-draining – will not freeze when installed in gravity drainage position.
- Automatically vents air and non-condensable gases and has a high (>**3:1**) cold water capacity for rapid start-up.
- Operates with **zero steam loss** throughout its operating range, saving steam and money during the life of the trap.
- Can be installed in any position.
- Small profile and lightweight for ease of use and maintenance.
- Internal stainless steel strainer.
- Three (3) year guarantee.



Pressure / Temperature Ratings				
Maximum Service Pressure	[psig]	<b>305</b>	<b>189</b>	<b>131</b>
	[barg]	21	13	9
Related Temperature	[°F]	<b>437</b>	<b>752</b>	<b>842</b>
	[°C]	225	400	450
Maximum Differential Pressure	<b>305 psi (21 bar)</b>			

Dimensions and Weights		End Connections	
		Screwed / Socketweld	
Nominal Sizes	[inch]	<b>3/8</b>	<b>1/2</b>
	[mm]	10	15
Dimensions	L [inch]	<b>3.7</b>	<b>3.7</b>
	[mm]	95	95
Approx. Weight	[lbs]	<b>1.5</b>	<b>1.8</b>
	[kg]	0.7	0.8

**Materials**

- Body and Cover – ASTM A105 (DIN 1.0460)
- Regulator – Hastelloy® and Stainless Steel
- Other Internals – Stainless Steel

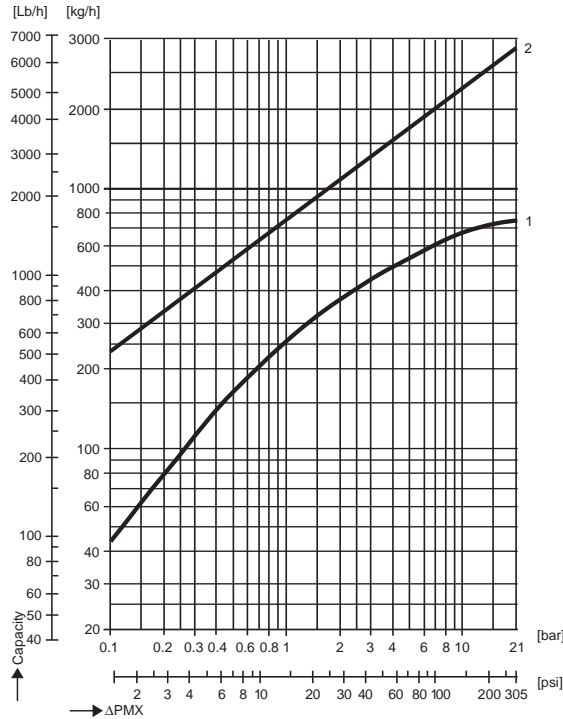
**305**  
psi  
Maximum  $\Delta p$   
(21 bar)

**Gestra® Steam Trap •  
Thermostatic Steam Trap**

**MK 35/32**

**Class Rating:** ANSI 300

**Available Sizes:** 3/8" and 1/2"  
(DN 10 and 15)



**Capacity Charts**

The charts show the maximum capacity for hot and cold condensate. The capacities are a function of differential pressure or the difference between inlet and outlet pressures for the trap.

Curve 1 shows the maximum capacity when discharging hot condensate that is **18°F (10°C)** below steam saturation temperature. For example, at a differential pressure of **100 psi**, the maximum hot capacity is approximately **1,450 lb/h**.

Curve 2 shows the maximum capacity when discharging cold condensate at a temperature of **68°F (20°C)**. For example, at a differential pressure of **100 psi**, the maximum cold capacity is approximately **4,400 lb/h**.

**Temperature Discharge Options**

The MK 35/32 steam trap is available with an optional undercooling capsule (**U**) for open discharge applications where sensible heat savings and flash steam suppression are desirable. This capsule discharges condensate at **54°F (30°C)** below saturation temperatures. Also available are hot (**H**) capsules that discharge condensate at **9°F (5°C)** below saturation temperatures. Please contact your local Flowserve Gestra representative for details.

**Body Pressure/Temperature Rating**

The chart shows the maximum shell (body) pressure and temperature rating. Regulator operating differential pressure is limited to **305 psi**.

**Material/Test Certificates**

All inspection requirements must be stated at time of order. Test certificates can be issued on request in accordance with EN 10204 – 2.2 and -3.1B. Body and Cover heat codes are required.

**Available End Connections**

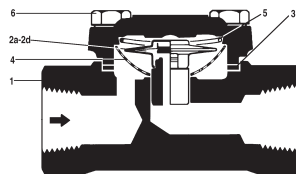
NPT, BSP

SW

**How to Order**

Specify trap, end connection size and type.

For Example: MK 35/32 1/2" (N) NPT



Standard Spare Parts		
Item Number	Description	MK 35/32
1	Body & Cover	
2a	Capsule (5N2)	376175
2b	Capsule (5U2)	376168
3	Cover Gasket	087080
4	Strainer	087401
5	Retaining Spring	098317



## Gestra® Steam Trap • Thermostatic Steam Trap

## MK 36/51 and MK 36/52

**465**  
psi  
Maximum Δp  
(32 bar)

**Class Rating:** ANSI 600

**Available Sizes:** 1/4", 3/8", 1/2" and 3/4"  
(DN 8, 10, 15 and 20)

### Application

The MK 36 series steam trap is used for low capacity applications such as drips and tracers where only saturated steam is used.

### Features and Benefits

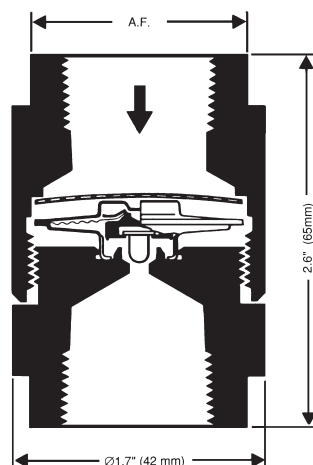
- Control capsule of Hastelloy® and Stainless Steel construction for corrosion resistance.
- Tandem seated design and venturi style orifice provides tight shutoff, cyclical discharge and superior dirt-handling ability.
- Small trap body and low weight – excellent for end of line tracer applications.
- Stainless steel construction for superior corrosion resistance.
- Discharges hot condensate at approximately **18°F** (10°C) below saturation temperature throughout its operating range. One internal regulator for all pressure ranges.
- Self-draining – will not freeze when installed in gravity drainage position.
- Resistant to waterhammer.
- Cyclical discharge eases audible/visual performance checking.
- Automatic start-up: Vents air and non-condensable gases with a high **(2:1)** cold water capacity for rapid start-up.
- Operates with **zero steam loss** throughout its operating range, saving steam and money during the life of the trap.
- Can be installed in any position.
- Internal stainless steel strainer.
- Three (3) year guarantee.

### Materials

- Body – ASTM A182 F304 (DIN 1.4301)
- Regulator – Hastelloy® and Stainless Steel
- Other Internals – Stainless Steel

### Pressure/Temperature Chart

The chart shows the maximum shell (body) pressure and temperature rating. Operating differential pressure is limited to **465 psi**.



Dimensions and Weights		End Connections			
		Screwed			
Nominal Sizes	[inch] [mm]	1/4 8	3/8 10	1/2 15	3/4 20
Dimensions	A.F. [inch] [mm]	1.1 27	1.1 27	1.1 27	1.4 36
Approx. Weight	[lbs] [kg]	1 0.4	1 0.4	1 0.4	1 0.4

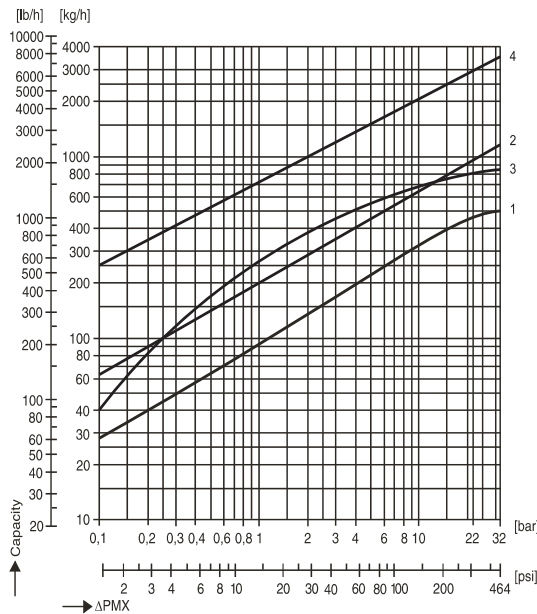
Pressure / Temperature Ratings				
Maximum Service Pressure	[psig]	<b>464</b>	<b>189</b>	<b>131</b>
	[barg]	32	13	9
Related Temperature	[°F]	<b>464</b>	<b>752</b>	<b>842</b>
	[°C]	240	400	450
Maximum Differential Pressure	<b>465 psig (32 barg)</b>			

**465**  
psi  
Maximum  $\Delta p$   
(32 bar)

## Gestra® Steam Trap • Thermostatic Steam Trap

## MK 36/51 and MK 36/52

**Class Rating:** ANSI 600



**Available Sizes:** 1/4", 3/8", 1/2" and 3/4"  
(DN 8, 10, 15 and 20)

### Capacity Charts

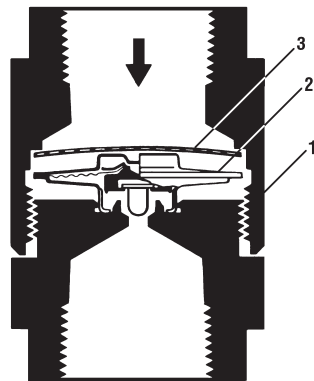
The charts show the maximum capacities for hot and cold condensate.

Curve 1 shows the maximum capacity when discharging hot condensate that is **18°F (10°C)** below steam saturation temperature. For example, at a differential pressure of **100 psi**, the maximum hot capacity is approximately **600 lb/h**.

Curve 2 shows the maximum capacity when discharging cold condensate at a temperature of **68°F (20°C)**. For example, at a differential pressure of **100 psi**, the maximum cold capacity is approximately **1,300 lb/h**.

Curve 3 shows the maximum capacity when discharging hot condensate that is **18°F (10°C)** below steam saturation temperature. For example, at a differential pressure of **100 psi**, the maximum hot capacity is approximately **1,360 lb/h**.

Curve 4 shows the maximum capacity when discharging cold condensate at a temperature of **68°F (20°C)**. For example, at a differential pressure of **100 psi**, the maximum cold capacity is approximately **4,000 lb/h**.



### Energy Savings

Flowserve Gestra MK 36 series steam traps are available with optional undercooling (**U**) capsules for open discharge applications where sensible heat savings and flash steam suppression are desirable. This capsule discharges condensate at **54°F (30°C)** below saturation temperature. Please contact your local Flowserve Gestra representative for details.

### Material/Test Certificates

Test certificates can be issued on request in accordance with EN 10204 – 2.2 and -3.1B. Test and/or Inspection certificates must be requested at time of order and cannot be issued after the equipment has been shipped from the factory.

### Available End Connections

Screwed sockets: NPT or BSP

### How to Order

Specify trap, end connection size and type.

For Example: MK 36/51 1/2" (N) NPT

Standard Spare Parts			
Item Number	Description	MK 36/5_	
1	Body		
2	Capsule		
		<b>Tandem Seat:</b> 5N1	376165
		5U1	376166
		5H1	376173
		<b>Flat Seat:</b> 5N2	376167
		5U2	376168
	5H2	376174	
3	Strainer	088503	

# Gestra® Steam Trap • RHOMBUSline® Thermostatic Steam Trap

**MK 45/1**

**465**  
psi  
Maximum Δp  
(32 bar)

**Class Rating:** ANSI 300

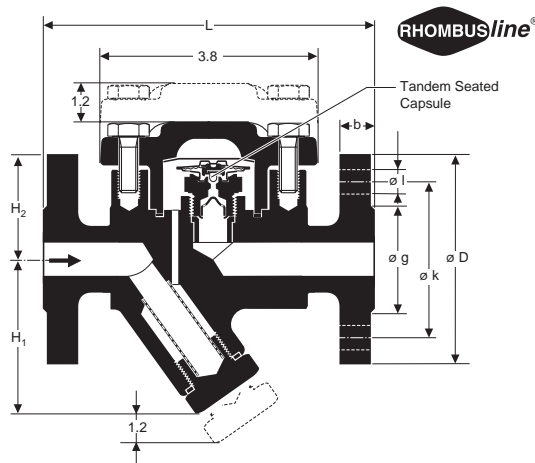
**Available Sizes:** 1/2", 3/4" and 1"  
(DN 8, 10, 15 and 20)

### Application

The **RHOMBUSline**® MK 45/1 steam trap is used for low capacity applications such as drip and tracing, and economically combines steam trap, check valve and Y-Strainer (with optional blow off valve) in a small profile with a convenient 2-bolt cover for easy maintenance.

### Features and Benefits

- Forged carbon steel body.
  - Tandem seated control capsule combined with a venturi style orifice uses a unique double valve and seat for tight shut off, cyclical discharge and superior dirt handling ability.
  - Discharges hot condensate at approximately **18°F** (10°C) below saturation temperature throughout its operating range. One internal regulator for all pressure ranges.
  - Cyclical discharge eases audible/visual performance checking.
  - Resistant to water hammer.
  - Self-draining – will not freeze when installed in gravity drainage position.
  - Automatically vents air and non-condensable gases and has a high (2:1) cold water capacity for rapid start-up.
  - Operates with **zero steam loss** throughout its operating range, saving steam and money during the life of the trap.
  - Easy in-line inspection and maintenance – mechanical stops prevent crushing of the gasket for extended gasket life.
  - Can be installed in any position.
  - Internal stainless steel Y-strainer with optional blow-off valve.
  - Replaceable seat with integral check valve.
  - Three (3) year guarantee.
- ### Materials
- Body and Cover – ASTM A105 (DIN 1.0460)
  - Cover Bolts – ASTM A193B7 (DIN 1.7258)
  - Regulator – Hastelloy® and Stainless Steel
  - Other Internals – Stainless Steel



Pressure / Temperature Ratings				
Maximum Service Pressure	[psig]	464	319	305
	[barg]	32	22	21
Related Temperature	[°F]	482	725	752
	[°C]	250	385	400
Maximum Differential Pressure		<b>465 psig (32 barg)</b>		

Dimensions and Weights		End Connections								
		Flanged			Screwed Socket-Weld			Butt-Weld		
		1/2	3/4	1	1/2	3/4	1	1/2	3/4	1
Nominal Sizes	[inch] [mm]	15	20	25	15	20	25	15	20	25
Dimensions	L [inch] [mm]	5.9	5.9	6.3	3.7			7.9		
	H1 [inch] [mm]	2.8			2.8			2.8		
	H2 [inch] [mm]	2.4			2.4			2.4		
	Approx. Weight	[lbs] [kg]	8.1 3.7	9.5 4.3	10.6 4.8	4.8 2.2	4.6 2.1	4.4 2	5.5 2.5	5.5 2.5

Flange Dimensions	End Connections								
	DIN			CL 150			CL 300		
D [inch] [mm]	3.7 95	4.1 105	4.5 115	3.5 88.9	3.9 98.4	4.2 107.9	3.7 95.2	4.6 117.5	4.9 123.8
b [inch] [mm]	0.6 16	0.7 18	0.7 18	0.4 11.1	0.5 12.7	0.6 14.3	0.6 14.3	0.6 15.9	0.7 17.5
k [inch] [mm]	2.6 65	3 75	3.3 85	2.4 60.3	2.7 69.8	3.1 79.4	2.6 66.7	3.2 82.5	3.5 88.9
g [inch] [mm]	1.8 45	2.3 58	2.7 68	1.4 34.9	1.7 42.9	2 50.8	1.4 34.9	1.7 42.9	2 50.8
l [inch] [mm]	0.6 14	0.6 14	0.6 14	0.6 15.9	0.6 15.9	0.6 15.9	0.6 15.9	0.7 19	0.7 19
Number of bolts	4	4	4	4	4	4	4	4	4

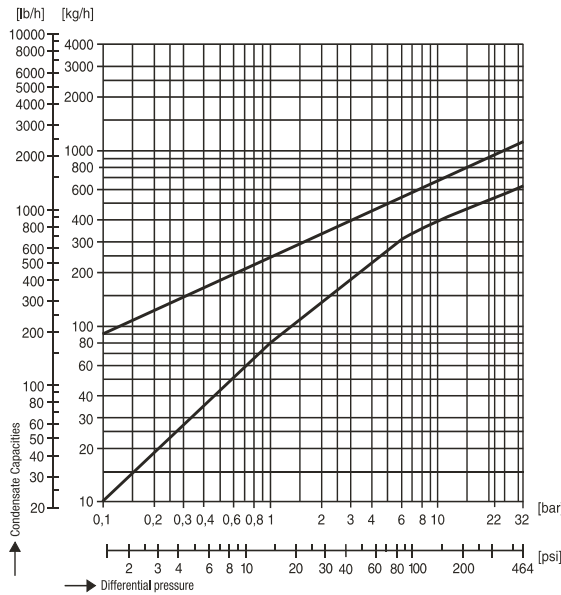
**465**  
psi  
Maximum  $\Delta p$   
(32 bar)

**Gestra® Steam Trap • RHOMBUSline®  
Thermostatic Steam Trap**

**MK 45/1**

**Class Rating:** ANSI 300

**Available Sizes:** ½", ¾" and 1"  
(DN 8, 10, 15 and 20)



**Capacity Charts**

The chart shows the maximum capacities for hot and cold condensate. The capacities are a function of differential pressure or the difference between inlet and outlet pressures for the trap.

Curve 1 shows the maximum capacity when discharging hot condensate that is **18°F (10°C)** below steam saturation temperature. For example, at a differential pressure of **100 psi** the maximum hot capacity is approximately **460 lb/h**.

Curve 2 shows the maximum capacity when discharging cold condensate at a temperature of **68°F (20°C)**. For example, at a differential pressure of **100 psi** the maximum cold capacity is approximately **1,200 lb/h**.

**Temperature Discharge Options**

Flowserve Gestra MK 45/1 steam traps are available with undercooling (**U**) capsules for open discharge applications where sensible heat savings and flash steam suppression are desirable. This capsule discharges condensate at **54°F (30°C)** below saturation temperatures. Please contact your Flowserve Gestra representative for details.

**Body Pressure/Temperature Chart**

The chart shows the maximum shell (body) pressure and temperature rating. Operating differential pressure is limited to **465 psi**.

**Material/Test Certificates**

All inspection requirements must be stated at time of order. Test certificates can be issued on request at extra cost in accordance with EN 10204 – 2.2 and -3.1B. Heat Codes on Body and Cover are required.

**Available End Connections**

Flanges: ANSI 150RF, 300RF (DIN, PN 40)

Screwed sockets: NPT, BSP

Socket-weld, Butt weld

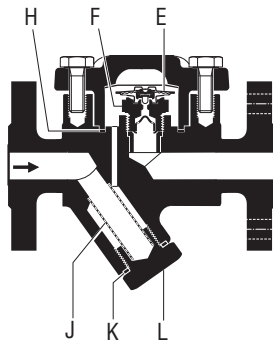
**How to Order**

Specify trap, end connection size and type.

For Example: MK 45/1 ½" NPT (N).

Add "w/BOV" if blow-off valve is desired.

If ANSI flanged ends are required, please specify either ANSI 150 RF or ANSI 300 RF.



Standard Spare Parts			
Item Number	Description		MK 45-1
E,F,H	Complete Membrane regulator including cover gasket	5N1 5U1	375109 375111
J, K, L	Complete Strainer set		375113
E	Thermostatic capsule	5N1 5U1	376165 376166
H	Cover Gasket		3750221
K	Strainer Gasket		013322

# Gestra® Steam Trap • RHOMBUSline® Thermostatic Steam Trap

**MK 45/2**

465

psi  
Maximum Δp  
(32 bar)

**Class Rating:** ANSI 300

**Available Sizes:** 1/2", 3/4" and 1"  
(DN 8, 10, 15 and 20)

**Application**

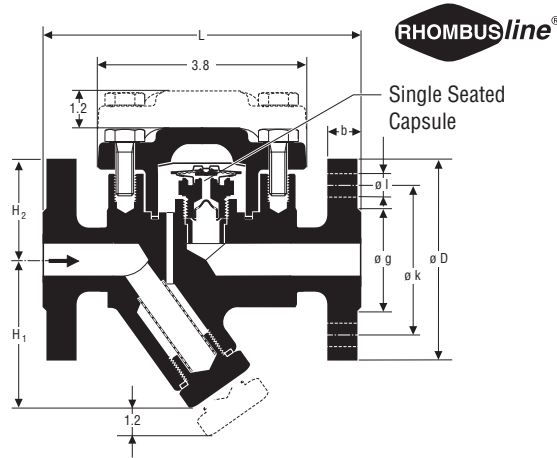
The **RHOMBUSline®** MK 45/2 steam trap is used for low capacity applications such as drip and tracing, and economically combines steam trap, check valve and **Y-Strainer** (with optional blow off valve) in a small profile with a convenient 2-bolt cover for easy maintenance.

**Features and Benefits**

- Forged carbon steel body.
- Discharges hot condensate at approximately **18°F** (10°C) below saturation temperature throughout its operating range. One internal regulator for all pressure ranges.
- Cyclical discharge eases audible/visual performance checking.
- Resistant to water hammer.
- Self-draining – will not freeze when installed in gravity drainage position.
- Automatically vents air and non-condensable gases and has a high **(2:1)** cold water capacity for rapid start-up.
- Operates with **zero steam loss** throughout its operating range saving steam and money during the life of the trap.
- Easy in-line inspection and maintenance – mechanical stops prevent crushing of the gasket for extended gasket life.
- Can be installed in any position.
- Internal stainless steel **Y**-strainer with optional blow-off valve.
- Replaceable seat with integral check valve.
- Three (3) year guarantee.

**Materials**

- Body and Cover – ASTM A105 (DIN 1.0460)
- Cover Bolts – ASTM A193B7 (DIN 1.7258)
- Regulator – Hastelloy® and Stainless Steel
- Other Internals – Stainless Steel



Pressure / Temperature Ratings		
Maximum Service Pressure	[psig]	464 319 305
	[barg]	32 22 21
Related Temperature	[°F]	482 725 752
	[°C]	250 385 400
Maximum Differential Pressure		<b>465</b> psig (32 barg)

Dimensions and Weights		End Connections								
		Flanged			Screwed Socket-Weld			Butt-Weld		
Nominal Sizes	[inch]	1/2	3/4	1	1/2	3/4	1	1/2	3/4	1
	[mm]	15	20	25	15	20	25	15	20	25
Dimensions	L [inch]	5.9	5.9	6.3	3.7			7.9		
	L [mm]	150	150	160	95			200		
	H1 [inch]	2.8			2.8			2.8		
	H1 [mm]	70			70			70		
H2 [inch]	2.4			2.4			2.4			
	62			62			62			
Approx. Weight	[lbs]	8.1	9.5	10.6	4.8	4.6	4.4	5.5	5.5	5.5
	[kg]	3.7	4.3	4.8	2.2	2.1	2	2.5	2.5	2.5

Flange Dimensions	End Connections											
	DIN			CL 150			CL 300					
D [inch]	3.7	4.1	4.5	3.5	3.9	4.2	3.7	4.6	4.9			
D [mm]	95	105	115	88.9	98.4	107.9	95.2	117.5	123.8			
b [inch]	0.6	0.7	0.7	0.4	0.5	0.6	0.6	0.6	0.7			
b [mm]	16	18	18	11.1	12.7	14.3	14.3	15.9	17.5			
k [inch]	2.6	3	3.3	2.4	2.7	3.1	2.6	3.2	3.5			
k [mm]	65	75	85	60.3	69.8	79.4	66.7	82.5	88.9			
g [inch]	1.8	2.3	2.7	1.4	1.7	2	1.4	1.7	2			
g [mm]	45	58	68	34.9	42.9	50.8	34.9	42.9	50.8			
l [inch]	0.6	0.6	0.6	0.6	0.6	0.6	0.6	0.7	0.7			
l [mm]	14	14	14	15.9	15.9	15.9	15.9	19	19			
Number of bolts	4	4	4	4	4	4	4	4	4			

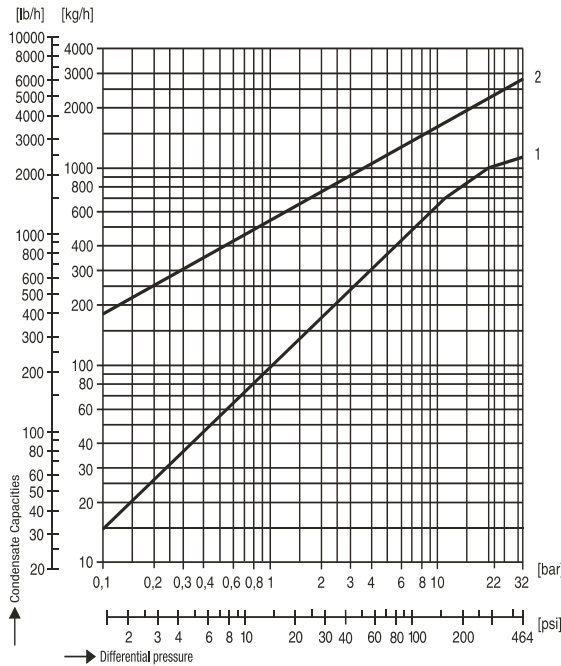
**465**  
psi  
Maximum  $\Delta p$   
(32 bar)

**Gestra® Steam Trap • RHOMBUSline®  
Thermostatic Steam Trap**

**MK 45/2**

**Class Rating:** ANSI 300

**Available Sizes:** ½", ¾" and 1"  
(DN 8, 10, 15 and 20)



**Capacity Charts**

The chart shows the maximum capacities for hot and cold condensate. The capacities are a function of differential pressure or the difference between inlet and outlet pressures for the trap.

Curve 1 shows the maximum capacity when discharging hot condensate that is **18°F (10°C)** below steam saturation temperature. For example, at a differential pressure of **100 psi** the maximum hot capacity is approximately **1,300 lb/h**.

Curve 2 shows the maximum capacity when discharging cold condensate at a temperature of **68°F (20°C)**. For example, at a differential pressure of **100 psi** the maximum cold capacity is approximately **4,000 lb/h**.

**Temperature Discharge Options**

Flowserve Gestra MK 45/2 steam traps are available with undercooling (**U**) capsules for open discharge applications where sensible heat savings and flash steam suppression are desirable. This capsule discharges condensate at **54°F (30°C)** below saturation temperatures. Also available are hot (**H**) temperature capsules that discharge condensate at **9°F (5°C)** below saturation temperatures. Please contact your Flowserve Gestra representative for details.

**Body Pressure/Temperature Chart**

The chart shows the maximum shell (body) pressure and temperature rating. Operating differential pressure is limited to **465 psi**.

**Material/Test Certificates**

All inspection requirements must be stated at time of order. Test certificates can be issued on request at extra cost in accordance with EN 10204 – 2.2 and -3.1B. Heat Codes on Body and Cover are required.

**Available End Connections**

Flanges: ANSI 150RF, 300RF (DIN, PN 40)

Screwed sockets: NPT, BSP

Socket-weld, Butt weld

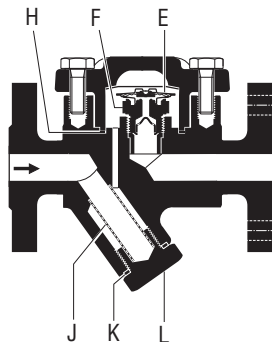
**How to Order**

Specify trap, end connection size and type.

For Example: MK 45/2 ½" NPT (N).

Add "w/BOV" if blow-off valve is desired.

If ANSI flanged ends are required, please specify either ANSI 150 RF or ANSI 300 RF.



Standard Spare Parts			
Item Number	Description		MK 45-2
E,F,H	Complete Membrane regulator including cover gasket	5N2 5U2	375110 375112
J, K, L	Complete Strainer set		375113
E	Thermostatic capsule	5N2 5U2	376175 376168
H	Cover Gasket		375022I
K	Strainer Gasket		013322

# Gestra® Steam Trap • Thermostatic Steam Trap

**MK 35/2S**

**465**  
psi  
Maximum Δp  
(32 bar)

**Class Rating:** ANSI 300

**Available Sizes:** 1"  
(DN 25)

**Application**

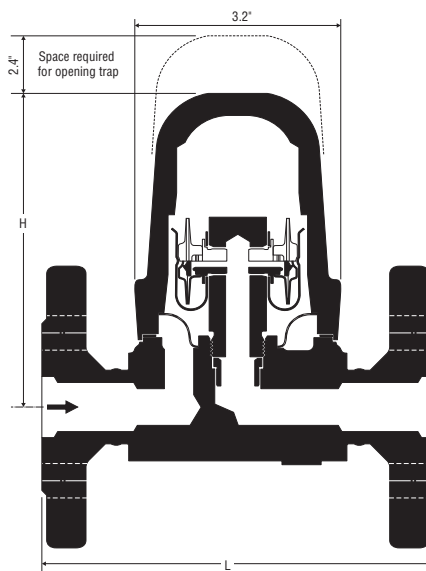
The MK 35/2S 1" steam trap is used for process service such as heat exchangers, tank coils, large air heaters, etc. The membrane thermostatic capsules in the trap operate independently and will adjust very quickly to changes in load. These traps are ideally suited for many process applications.

**Features and Benefits**

- Two (2) modulating control capsules of Hastelloy® and Stainless Steel for superior corrosion resistance that independently control the flow of condensate.
- Standard (H) capsules discharge hot condensate in a modulating fashion at approximately 9°F (5°C) below saturation temperature throughout its operating range.
- Very compact and lightweight design relative to other comparable steam traps in its capacity range, saving time in installation and piping.
- Resistant to water hammer.
- Self-draining – will not freeze when installed in gravity drainage position.
- Automatically vents air and non-condensable gases and has a high (>2:1) cold water capacity for rapid start-up.
- Operates with **zero steam loss** throughout its operating range saving steam and money during the life of the trap.
- Can be installed in any position.
- Internal stainless steel strainer.
- Internal check valve.
- Three (3) year guarantee.

**Materials**

- Body – ASTM A105 (DIN 1.0460)
- Capsules – Hastelloy® and Stainless Steel
- Other Internals – Stainless Steel



Pressure / Temperature Ratings				
Maximum Service Pressure	[psig]	464	319	305
	[barg]	32	22	21
Related Temperature	[°F]	482	725	752
	[°C]	250	385	400
Maximum Differential Pressure		<b>465 psig (32 barg)</b>		

Dimensions and Weights		End Connections			
		Butt-Weld	Screwed / Socket Weld	Flanged	
Nominal Sizes	[inch]	<b>1</b>	<b>1</b>	<b>1</b>	
	[mm]	25	25	25	
Dimensions	L	[inch]	<b>9.8</b>	<b>3.7</b>	<b>6.3</b>
		[mm]	250	95	160
	H	[inch]	<b>4.9</b>	<b>4.9</b>	<b>4.9</b>
		[mm]	124	124	124
Approx. Weight	[lbs]	<b>10</b>	<b>9</b>	<b>14</b>	
	[kg]	4.4	3.9	6.3	

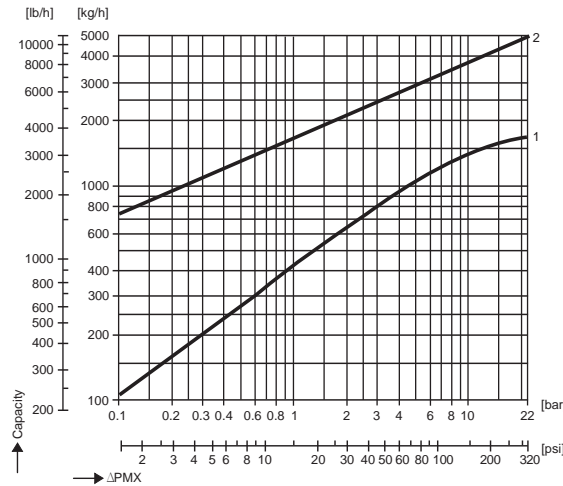
**465**  
psi  
Maximum  $\Delta p$   
(32 bar)

**Gestra® Steam Trap •  
Thermostatic Steam Trap**

**MK 35/2S**

**Class Rating:** ANSI 300

**Available Sizes:** 1"  
(DN 25)



**Capacity Charts**

The charts show the maximum capacities for hot and cold condensate. The capacities are a function of differential pressure or the difference between inlet and outlet pressures for the trap.

Curve 1 shows the maximum capacity when discharging hot condensate that is **9°F (5°C)** below steam saturation temperature. For example, at a differential pressure of **100 psi** the maximum hot capacity is approximately **2,700 lb/hr.**

Curve 2 shows the maximum capacity when discharging cold condensate at a temperature of **68°F (20°C)**. For example, at a differential pressure of **100 psi** the maximum cold capacity is approximately **6,900 lb/hr.**

**Body Pressure/Temperature Rating**

The chart shows the maximum shell (body) pressure and temperature rating. Operating differential pressure is limited to **465 psi.**

**Material/Test Certificates**

Test certificates can be issued on request in accordance with EN 10204 – 2.2 and -3.1B. All inspection requirements must be stated with the order. Heat codes from body and cover are required.

**Available End Connections**

NPT, BSP

Flanged: ANSI 150, 300

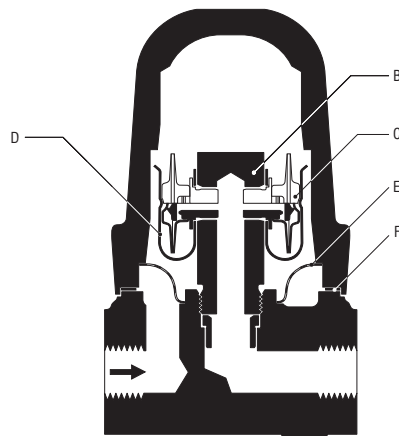
SW

**How to Order**

Specify trap, end connection size and type.

For Example: MK 35/2S 1" (H) NPT

**NOTE:** There are many factors that can affect the performance of a high capacity process steam trap. Please consult your local Gestra representative prior to installation.



Standard Spare Parts		
Item Number	Description	MK 35/2S
R	Regulator with cover gasket Includes items B, C, D, & F	376730
C	Capsule 5H2	376174
F	Cover gasket	560493
E	Strainer & Cover gasket kit	376732



# Gestra® Steam Trap • Thermostatic Steam Trap

**MK 35/2S3**

465

psi  
Maximum Δp  
(32 bar)

**Class Rating:** ANSI 300

**Available Sizes:** 1"  
(DN 25)

**Application**

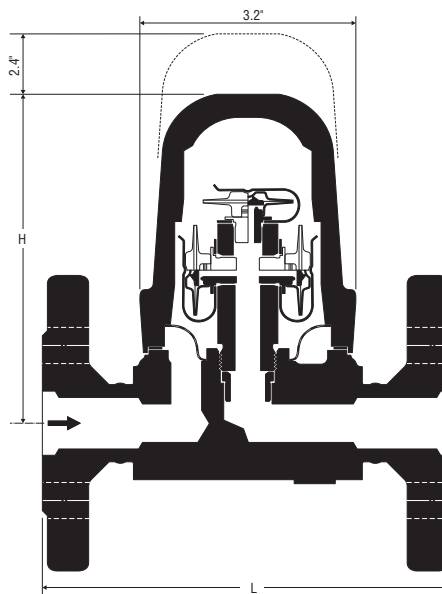
The MK 35/2S3 1" steam trap is used for process service such as heat exchangers, tank coils, large air heaters, etc. The membrane thermostatic capsules in the trap operate independently and will adjust very quickly to changes in load. These traps are ideally suited for many process applications.

**Features and Benefits**

- Three (3) modulating control capsules of Hastelloy® and Stainless Steel for superior corrosion resistance that independently control the flow of condensate in a modulating fashion for good temperature control and smooth condensate flow.
- Standard (H) capsules discharge hot condensate at approximately 9°F (5°C) below saturation temperature throughout its operating range.
- Very compact and lightweight design relative to other comparable steam traps in its capacity range. This saves time in installation and piping.
- Resistant to water hammer.
- Self-draining – will not freeze when installed in gravity drainage position.
- Automatically vents air and non-condensable gases and has a high (>2:1) cold water capacity for rapid start-up.
- Operates with **zero steam loss** throughout its operating range saving steam and money during the life of the trap.
- Can be installed in any position.
- Internal stainless steel strainer.
- Three (3) year guarantee.

**Materials**

- Body and Cover – ASTM A105 (DIN 1.0460)
- Capsules – Hastelloy® and Stainless Steel
- Other Internals – Stainless Steel



Pressure / Temperature Ratings				
Maximum Service Pressure	[psig]	464	319	305
	[barg]	32	22	21
Related Temperature	[°F]	482	725	752
	[°C]	250	385	400
Maximum Differential Pressure	<b>465 psig (32 barg)</b>			

Dimensions and Weights		End Connections		
		Butt-Weld	Screwed / Socket Weld	Flanged
Nominal Sizes	[inch]	1	1	1
	[mm]	25	25	25
Dimensions	L [inch]	9.8	3.7	6.3
	[mm]	250	95	160
	H [inch]	4.9	4.9	4.9
	[mm]	124	124	124
Approx. Weight	[lbs]	10	9	14
	[kg]	4.4	3.9	6.3

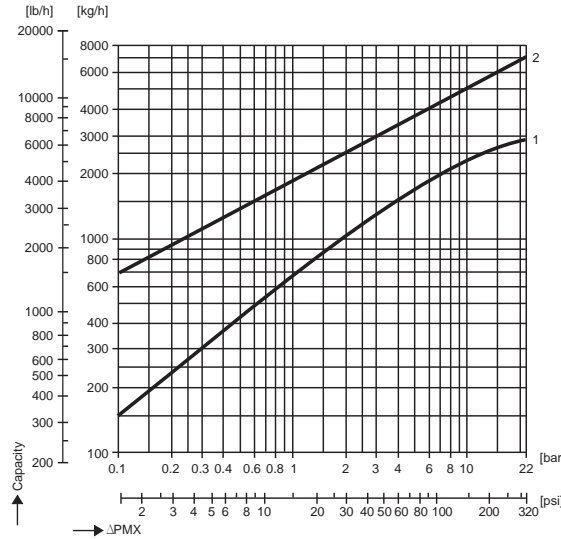
**465**  
psi  
Maximum  $\Delta p$   
(32 bar)

**Gestra® Steam Trap •  
Thermostatic Steam Trap**

**MK 35/2S3**

**Class Rating:** ANSI 300

**Available Sizes:** 1"  
(DN 25)



**Capacity Charts**

The charts show the maximum capacities for hot and cold condensate. The capacities are a function of differential pressure or the difference between inlet and outlet pressures for the trap.

Curve 1 shows the maximum capacity when discharging hot condensate that is **9°F (5°C)** below steam saturation temperature. For example, at a differential pressure of **100 psi** the maximum hot capacity is approximately **4,000 lb/hr.**

Curve 2 shows the maximum capacity when discharging cold condensate at a temperature of **68°F (20°C)**. For example, at a differential pressure of **100 psi** the maximum cold capacity is approximately **9,000 lb/hr.**

**Body Pressure/Temperature Rating**

The chart shows the maximum shell (body) pressure and temperature rating. Operating differential pressure is limited to **465 psi.**

**Material/Test Certificates**

Test certificates can be issued on request in accordance with EN 10204 – 2.2 and -3.1B. All inspection requirements must be stated with the order. Heat codes from body and cover are required.

**Available End Connections**

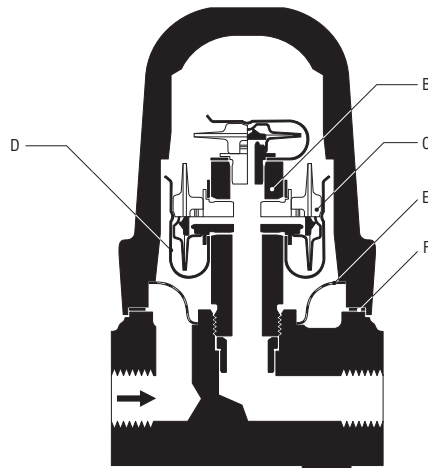
NPT, BSP  
Flanged: ANSI 150, 300  
SW

**How to Order**

Specify trap, end connection size and type.

For Example: MK 35/2S3 1" NPT

**NOTE:** There are many factors that can affect the performance of a process steam trap. Please contact your local Flowserve Gestra representative prior to installation.



Standard Spare Parts		
Item Number	Description	MK 35/2S3
R	Regulator with cover gasket Includes items B, C, D, & F	376731
C	Capsule 5H2	376174
F	Cover gasket	560493
E	Strainer & Cover gasket kit	376732

# Gestra® Steam Trap • Thermostatic Steam Trap

**MK 25/2**

**465**

psi  
Maximum Δp  
(32 bar)

**Class Rating:** ANSI 300

**Available Sizes:** 1½" and 2"  
(DN 40 and 50)

**Application**

The MK 25/2 steam trap is used for process service such as heat exchangers, tank coils, large air heaters, etc. The membrane thermostatic capsules in the trap operate independently and will adjust very quickly to changes in load. These traps are ideally suited for many process applications.

**Features and Benefits**

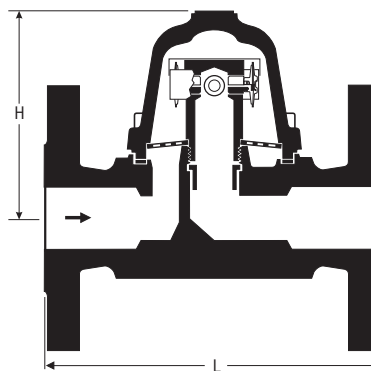
- Four (4) modulating control capsules of Hastelloy® and Stainless Steel for superior corrosion resistance that independently control the flow of condensate in a modulating fashion for good temperature control and smooth condensate flow.
- Standard (H) capsules discharge hot condensate at approximately 9°F (5°C) below saturation temperature throughout its operating range.
- Very compact and lightweight design relative to other comparable steam traps in its capacity range. This saves time in installation and piping.
- Resistant to water hammer.
- Self-draining – will not freeze when installed in gravity drainage position.
- Automatically vents air and non-condensable gases and has a high (>2:1) cold water capacity for rapid start-up.
- Operates with zero steam loss throughout its operating range saving steam and money during the life of the trap.
- Can be installed in any position.
- Internal stainless steel strainer.
- Three (3) year guarantee.

**Materials**

- Body and Cover – ASTM A105 (DIN 1.0460)
- Capsules – Hastelloy® and Stainless Steel
- Other Internals – Stainless Steel

**Body Pressure/Temperature Rating**

The chart shows the maximum shell (body) pressure and temperature rating. Operating differential pressure is limited to **465 psi**.



Pressure / Temperature Ratings				
Maximum Service Pressure	[psig]	464	319	305
	[barg]	32	22	21
Related Temperature	[°F]	482	725	752
	[°C]	250	385	400
Maximum Differential Pressure	<b>465</b> psig (32 barg)			

Dimensions and Weights		End Connections			
		Screwed / Socket Weld		Flanged	
Nominal Sizes	[inch]	<b>1 1/2</b>	<b>2</b>	<b>1 1/2</b>	<b>2</b>
	[mm]	40	50	40	50
Dimensions	L [inch]	<b>5.1</b>	<b>8.3</b>	<b>9.1</b>	<b>9.1</b>
		[mm]	130	210	230
	H [inch]	<b>4.9</b>	<b>4.9</b>	<b>4.9</b>	<b>4.9</b>
		[mm]	124	124	124
Approx. Weight	[lbs]	<b>14</b>	<b>17</b>	<b>24</b>	<b>28</b>
	[kg]	6.3	7.7	11	12.5

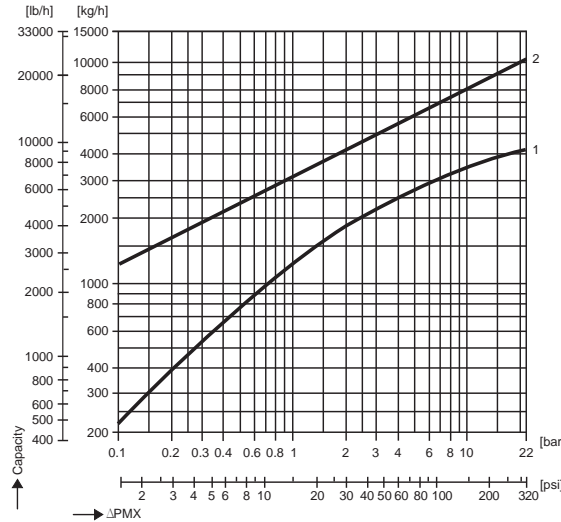
**465**  
psi  
Maximum  $\Delta p$   
(32 bar)

**Gestra® Steam Trap •  
Thermostatic Steam Trap**

**MK 25/2**

**Class Rating:** ANSI 300

**Available Sizes:** 1½" and 2"  
(DN 40 and 50)



**Capacity Charts**

The curves show the maximum capacity for hot and cold condensate. The capacities are a function of differential pressure or the difference between inlet and outlet pressures for the trap.

Curve 1 shows the maximum capacity when discharging hot condensate that is **9°F (5°C)** below steam saturation temperature. For example, at a differential pressure of **100 psi** the maximum hot capacity is approximately **6,700 lb/hr.**

Curve 2 shows the maximum capacity when discharging cold condensate at a temperature of **68°F (20°C)**. For example, at a differential pressure of **100 psi** the maximum cold capacity is approximately **14,000 lb/hr.**

**Material/Test Certificates**

Test certificates can be issued on request in accordance with EN 10204 – 2.2 and -3.1B. All inspection requirements must be stated with the order. Heat codes from body and cover are required.

**Available End Connections**

NPT, BSP

Flanged: ANSI 150RF, 300RF

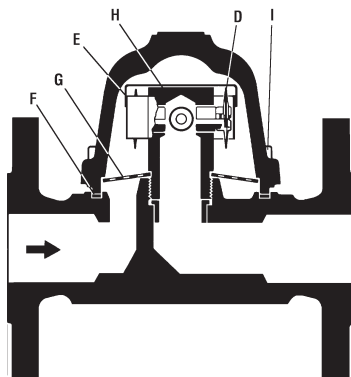
Socket-weld

**How to Order**

Specify trap, end connection size and type.

For Example: MK 25/2 2" NPT

**NOTE:** There are many factors that can affect the performance of a process steam trap. Please call your local Flowserve Gestra representative prior to installation.



Standard Spare Parts		
Item Number	Description	MK 25/2
D	Regulating Membrane 5H2 5OH2	376174 085184
E	Spring Retainer	098897
F	Cover Gasket	087095
G	Strainer	096891
H	Nozzle Seat	097029
I	Cover Bolts	011254

# Gestra® Steam Trap • Thermostatic Steam Trap

**MK 25/2S**

**465**  
psi  
Maximum Δp  
(32 bar)

**Class Rating:** ANSI 300

**Available Sizes:** 1½" and 2"  
(DN 40 and 50)

### Application

The MK 25/2S steam trap is used for process service such as heat exchangers, tank coils, large air heaters, etc. The traps should be sized according to the capacity required by the application. The membrane thermostatic capsules in the trap operate independently and will adjust very quickly to changes in load. These traps are ideally suited for many process applications.

### Features and Benefits

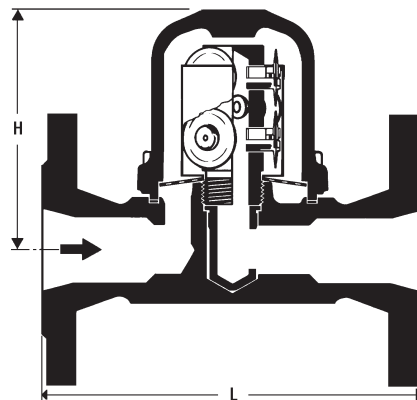
- Nine (9) modulating control capsules of Hastelloy® and Stainless Steel for superior corrosion resistance that independently control the flow of condensate.
- Standard (H) capsules discharge hot condensate in a modulating fashion at approximately 9°F (5°C) below saturation temperature throughout its operating range.
- Resistant to water hammer.
- Self-draining – will not freeze when installed in gravity drainage position.
- Automatically vents air and non-condensable gases and has a high (>2:1) cold water capacity for rapid start-up.
- Very compact and lightweight design relative to other comparable steam traps in its capacity range. This saves time in installation and piping.
- Operates with **zero steam loss** throughout its operating range saving steam and money during the life of the trap.
- Can be installed in any position.
- Internal stainless steel strainer.
- Three (3) year guarantee.

### Materials

- Body and Cover – ASTM A105 (DIN 1.0460)
- Capsules – Hastelloy® and Stainless Steel
- Other Internals – Stainless Steel

### Body Pressure/Temperature Rating

The chart shows the maximum shell (body) pressure and temperature rating. Operating differential pressure is limited to **465 psi**.



Pressure / Temperature Ratings				
Maximum Service Pressure	[psig]	464	319	305
	[barg]	32	22	21
Related Temperature	[°F]	482	725	752
	[°C]	250	385	400
Maximum Differential Pressure	<b>465</b> psig (32 barg)			

Dimensions and Weights		End Connections				
		Screwed / Socket Weld		Flanged		
Nominal Sizes	[inch]	1 1/2	2	1 1/2	2	
	[mm]	40	50	40	50	
Dimensions	L	[inch]	5.1	8.3	9.1	9.1
		[mm]	130	210	230	230
	H	[inch]	5.7	5.7	5.7	5.7
		[mm]	146	146	146	146
Approx. Weight	[lbs]	15	19	25	29	
	[kg]	6.8	8.5	11.5	13	

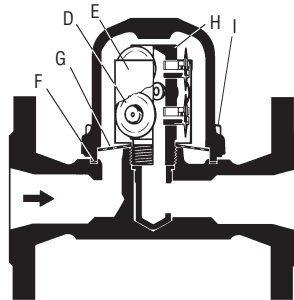
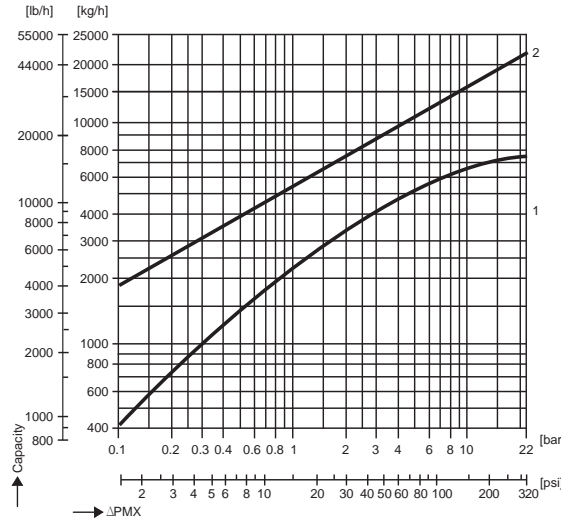
**465**  
psi  
Maximum  $\Delta p$   
(32 bar)

**Gestra® Steam Trap •  
Thermostatic Steam Trap**

**MK 25/2S**

**Class Rating:** ANSI 300

**Available Sizes:** 1½" and 2"  
(DN 40 and 50)



**Capacity Charts**

The charts show the maximum capacities for hot and cold condensate. The capacities are a function of differential pressure or the difference between inlet and outlet pressures for the trap.

Curve 1 shows the maximum capacity when discharging hot condensate that is **9°F (5°C)** below steam saturation temperature. For example, at a differential pressure of **100 psi** the maximum hot capacity is approximately **13,000 lb/hr.**

Curve 2 shows the maximum capacity when discharging cold condensate at a temperature of **68°F (20°C)**. For example, at a differential pressure of **100 psi** the maximum cold capacity is approximately **29,000 lb/hr.**

**Material/Test Certificates**

Test certificates can be issued on request in accordance with EN 10204 – 2.2 and -3.1B. All inspection requirements have to be stated with the order. Heat codes from body and cover are required.

**Available End Connections**

- NPT, BSP
- Flanged: ANSI 150RF, 300RF
- Socket-weld

**How to Order**

Specify trap, end connection size and type.

For Example: MK 25/2S 2" (H) NPT

**NOTE:** Many factors can affect the performance of a high capacity process steam trap. Please consult your Flowserve Gestra representative prior to installation.

Standard Spare Parts		
Item Number	Description	MK 25/2S
D	Regulating Membrane 5H2 5OH2	376174 085184
E	Spring Retainer	097637
F	Cover Gasket	087095
G	Strainer	096891
H	Nozzle Seat	097633
I	Cover Bolts	011254

# Gestra® Steam Trap • Thermostatic Steam Trap

## TK 23 and TK 24

**200**  
psi  
Maximum Δp  
(14 bar)

**Class Rating:** TK 23 – PN 16  
TK 24 – PN 25

**Available Sizes:** 2"  
(DN 50)

### Application

The TK 23 and TK 24 steam traps are used for very high capacity process load applications such as large heat exchangers, reboilers, digesters and rotating dryers. Both the TK 23 and the TK 24 are operationally identical; however, the materials of construction are changed to allow for higher maximum operating conditions for the TK 24.

TK 23: Cast Iron, **145 psi** Maximum Δp

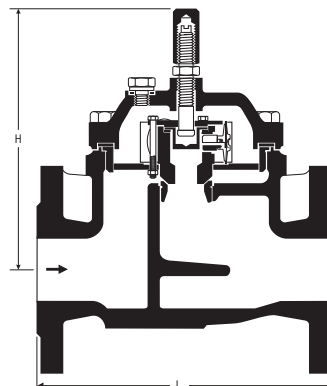
TK 24: Cast Steel, **200 psi** Maximum Δp

### Features and Benefits

- Three (3) modulating control capsules of Hastelloy® and Stainless Steel construction for corrosion resistance control pilot flow. Subsequent equalization of pressures provide for full stem lift, opening very large orifice.
- Standard (H) capules discharge hot condensate in a modulating fashion at approximately **9°F (5°C)** below saturation temperature throughout its operating range.
- Resistant to water hammer.
- Very compact and lightweight design relative to other comparable steam traps in its capacity range. This saves time in installation and piping.
- Automatically vents air and non-condensable gases and has a high (>2:1) cold water capacity for rapid start-up.
- External adjustment allows for passage of live steam (for rolling drum dryers and siphon lift applications as a steam lock release), or limits the capacity to provide for smoother flows where the application may have a smaller load than the full trap capacity.
- Top access plug provided for easy in-line cleaning or for pressure balancing.
- Two (2) year guarantee.

### Materials

- Body and Cover: TK 23 – Cast Iron – ASTM A126 CL. B (DIN 0.6025)  
TK 24 – Cast Steel – ASTM A216 WCB (DIN 1.0619)
- Capsules – Hastelloy® and Stainless Steel
- Other Internals – Stainless Steel



Pressure / Temperature Ratings				
Body Style		TK 23		TK 24
Maximum Operating Pressure	[psig] [barg]	<b>185</b> 13	<b>305</b> 21	
Maximum Operating Temperature	Saturated steam temperature relative to the applied pressure			
Maximum Service Pressure	[psig] [barg]	<b>230</b> 16	<b>145</b> 10	<b>360</b> 25
Related Temperature	[°F]	<b>248</b>	<b>572</b>	<b>248</b>
	[°C]	120	300	120
Maximum Differential Pressure	<b>145 psig (10 barg)</b>		<b>200 psig (14 barg)</b>	

Dimensions and Weights		Body Style	
		TK 23	TK 24
Nominal Sizes	[inch]	<b>2</b>	<b>2</b>
	[mm]	50	50
Dimensions	L	[inch]	<b>9.1</b>
		[mm]	230
	H	[inch]	<b>8.0</b>
		[mm]	202
Approx. Weight	[lbs]	<b>35</b>	<b>37</b>
	[kg]	16	17

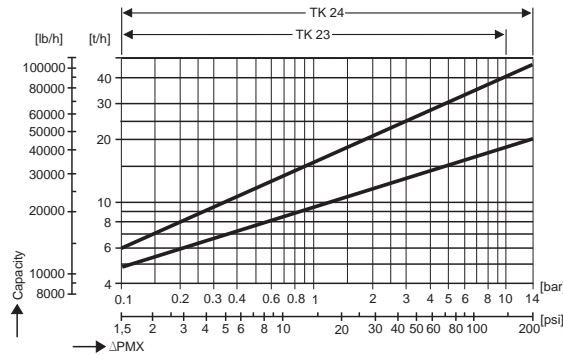
**200**  
psi  
Maximum  $\Delta p$   
(14 bar)

## Gestra® Steam Trap • Thermostatic Steam Trap

## TK 23 and TK 24

**Class Rating:** TK 23 – PN 16  
TK 24 – PN 25

**Available Sizes:** 2"  
(DN 50)



### Capacity Charts

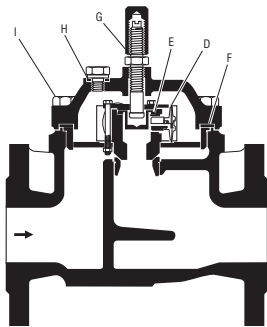
The charts show the maximum capacities for hot and cold condensate. The capacities are a function of differential pressure or the difference between inlet and outlet pressures for the trap.

The same chart is used for both the TK 23 and the TK 24.

Curve 1 shows the maximum capacity when discharging hot condensate that is **9°F (5°C)** below steam saturation temperature. For example, at a differential pressure of **100 psi** the maximum hot capacity is approximately **36,300 lb/hr.**

Curve 2 shows the maximum capacity when discharging cold condensate at a temperature of **68°F (20°C)**. For example, at a differential pressure of **100 psi** the maximum cold capacity is approximately **80,000 lb/hr.**

For differential pressures below **15 psi** (and a maximum upstream pressure of **70 psig**), Gestra recommends the use of the 'OH' membrane capsule to enhance the responsiveness of the steam trap. Please consult your local Flowserve Gestra representative for details.



### Body Pressure/Temperature Rating

The chart shows the maximum shell (body) pressure and temperature rating. Operating differential pressure is limited to **145 psi** for the TK 23 and **200 psi** for the TK 24.

### Material/Test Certificates

Test certificates can be issued on request in accordance with EN 10204 – 2.2 and -3.1B. All inspection requirements must be stated with the order. Heat codes from body and cover are required.

### Available End Connections

Flanged: TK 23 – ANSI 125 FF

TK 24 – ANSI 150 RF, 300 RF

### How to Order

Specify trap, end connection size and type.

For Example: TK 24 2" ANSI 300 RF

**NOTE:** Many factors can affect the performance of a high capacity process steam trap. Please consult your Flowserve Gestra representative prior to installation.

Standard Spare Parts		
Item Number	Description	TK 23/24
D	Regulating Membrane	5H2 376174
		5OH2 376272
E	Regulator Gasket	370215
F	Cover Gasket	087509
G	Adjustment Assembly Gasket	013327
H	Plug Gasket	000992
I	Cover Bolts	TK 23 011519
		TK 24 010085



# Gestra® Steam Trap • Thermostatic Steam Trap

## TK 23 and TK 24

**200**  
psi  
Maximum Δp  
(14 bar)

**Class Rating:** TK 23 – PN 16  
TK 24 – PN 25

**Available Sizes:** 2½", 3" and 4"  
(DN 65, 80 and 100)

### Application

The TK 23 and TK 24 steam traps are used for very high capacity process load applications such as large heat exchangers, reboilers, digesters and rotating dryers. Both the TK 23 and the TK 24 are operationally identical; however, the materials of construction are changed to allow for higher maximum operating conditions for the TK 24.

TK 23: Cast Iron, **145 psi** Maximum Δp

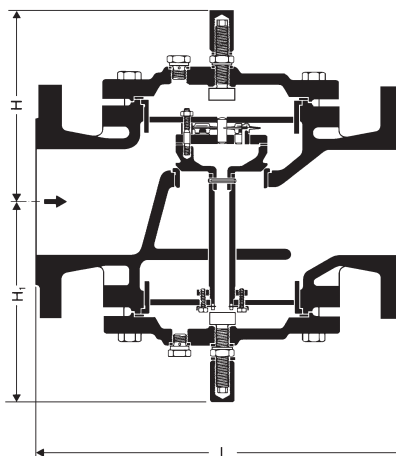
TK 24: Cast Steel, **200 psi** Maximum Δp

### Features and Benefits

- Four (4) modulating control capsules of Hastelloy® and Stainless Steel construction for corrosion resistance control pilot flow. Subsequent equalization of pressures provide for full stem lift, opening very large orifice.
- Standard (H) capules discharge hot condensate in a modulating fashion at approximately 9°F (5°C) below saturation temperature throughout its operating range.
- Resistant to water hammer.
- Very compact and lightweight design relative to other comparable steam traps in its capacity range. This saves time in installation and piping.
- Automatically vents air and non-condensable gases and has a high cold water capacity for rapid start-up.
- Two (2) external adjustments allow for passage of live steam (for rolling drum dryers and siphon lift applications as a steam lock release), or to limit the capacity to provide for smoother flows where the application may have a smaller load than the full trap capacity.
- Top and Bottom access plugs provided for easy in-line cleaning or pressure balancing.
- Two (2) year guarantee.

### Materials

- Body and Cover: TK 23 – Cast Iron – ASTM A126 CL. B (DIN 0.6025)  
TK 24 – Cast Steel – ASTM A216 WCB (DIN 1.0619)
- Capsule – Hastelloy® and Stainless Steel
- Other Internals – Stainless Steel



Pressure / Temperature Ratings			
Body Style		TK 23	TK 24
Maximum Operating Pressure	[psig]	185	305
	[barg]	13	21
Maximum Operating Temperature		Saturated steam temperature relative to the applied pressure	
Maximum Service Pressure	[psig]	230	360
	[barg]	16	25
Related Temperature	[°F]	248	572
	[°C]	120	300
Maximum Differential Pressure		145 psig (10 barg)	200 psig (14 barg)

Dimensions and Weights		Body Style					
		TK 23	TK 24	TK 23	TK 24	TK 23	TK 24
Nominal Sizes	[inch]	2 1/2	2 1/2	3	3	4	4
	[mm]	65	65	80	80	100	100
Dimensions	L [inch]	11.4	11.4	12.2	12.2	13.8	13.8
	[mm]	290	290	310	310	350	350
	H [inch]	6.9	7.1	6.9	7.1	6.9	7.1
	[mm]	175	180	175	180	175	180
H1	[inch]	6.9	6.7	6.9	6.7	7.4	7.4
	[mm]	175	170	175	170	188	188
Approx. Weight	[lbs]	55	62	59	68	95	128
	[kg]	25	28	27	31	43	58

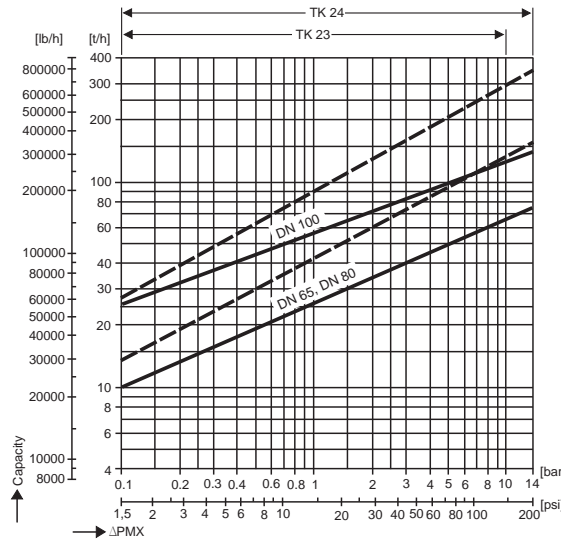
**200**  
psi  
Maximum  $\Delta p$   
(14 bar)

## Gestra® Steam Trap • Thermostatic Steam Trap

## TK 23 and TK 24

**Class Rating:** TK 23 – PN 16  
TK 24 – PN 25

**Available Sizes:** 2½", 3" and 4"  
(DN 65, 80 and 100)



### Capacity Charts

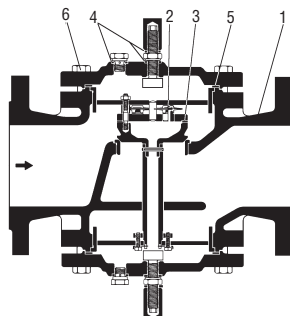
The charts show the maximum capacities for hot and cold condensate. The capacities are a function of differential pressure or the difference between inlet and outlet pressures for the trap.

The same chart is used for both the TK 23 and the TK 24.

Curve 1 shows the maximum capacity when discharging hot condensate that is **9°F (5°C)** below steam saturation temperature. For example, at a differential pressure of **100 psi** the maximum hot capacity is approximately **140,000 lb/hr**.

Curve 2 shows the maximum capacity when discharging cold condensate at a temperature of **68°F (20°C)**. For example, at a differential pressure of **100 psi** the maximum cold capacity is approximately **250,000 lb/hr**.

For differential pressures below **15 psi** and a maximum upstream pressure of **70 psig**, Flowserve Gestra recommends the use of the 'OH' membrane capsule to enhance the responsiveness of the steam trap. Please consult your local Flowserve Gestra representative for details.



### Pressure/Temperature Rating

The chart shows the maximum shell (body) pressure and temperature rating. Operating differential pressure is limited to **145 psi** for the TK 23 and **200 psi** for the TK 24.

### Material/Test Certificates

Test certificates can be issued on request in accordance with EN 10204 – 2.2 and -3.1B. All inspection requirements must be stated with the order. Heat Codes from body and cover are required.

### Available End Connections

Flanged: TK 23 – ANSI 125 FF  
TK 24 – ANSI 150 RF

### How to Order

Specify trap, end connection size and type.

For Example: TK 24 3" ANSI 300 RF

**NOTE:** Many factors can affect the performance of a high capacity process steam trap. Please consult your Flowserve Gestra representative prior to installation.

Standard Spare Parts		
Item Number	Description	TK 23 / 24
1	Body	
2	Regulating Membrane 5H2 5OH2	376174 376272
3	Seat Gasket	370216
4	Cover Gasket 2 1/2" to 3" 4"	087510 087511
G	Adjustment Assembly Gasket	000992
I	Cover Bolts	TK 23 011519 TK 24 011133

## Steam Traps BK

**Thermostatic steam traps with Duo stainless steel (bimetallic) regulator**

**Pressure ratings up to PN 630.**

**For roughest operating conditions. Unexcelled service life.**

**Operating principle resulting in a sturdy design unaffected by waterhammer and frost.**

**May also be used as air vents.**

### Operation

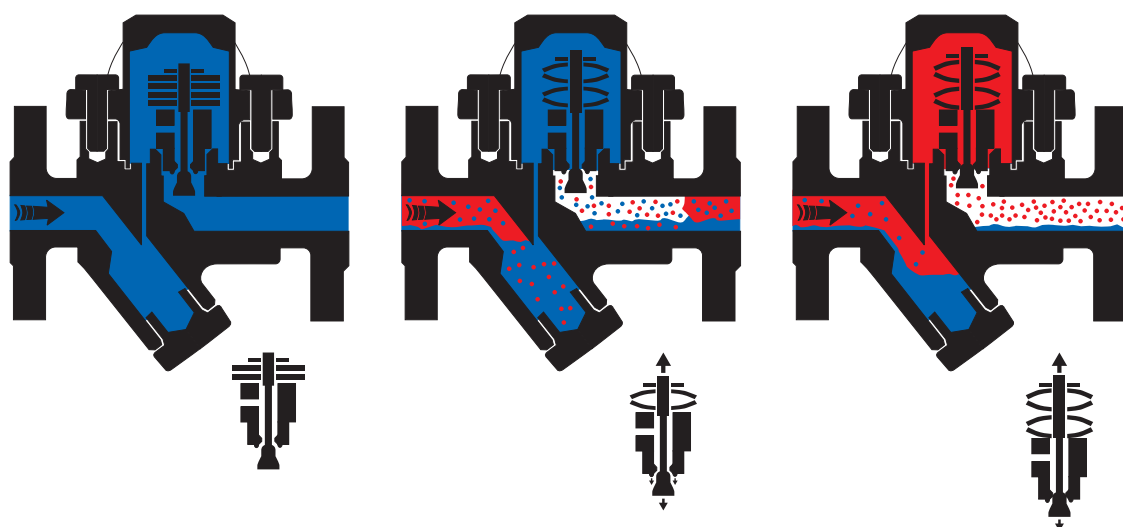
Opening and closing are controlled by the temperature sensor of Duo stainless steel plates and the stage nozzle operating together. During start-up of the plant and in the presence of cold condensate and air, the Duo stainless steel plates are flat. The service pressure acts in the opening direction; the valve is completely open.

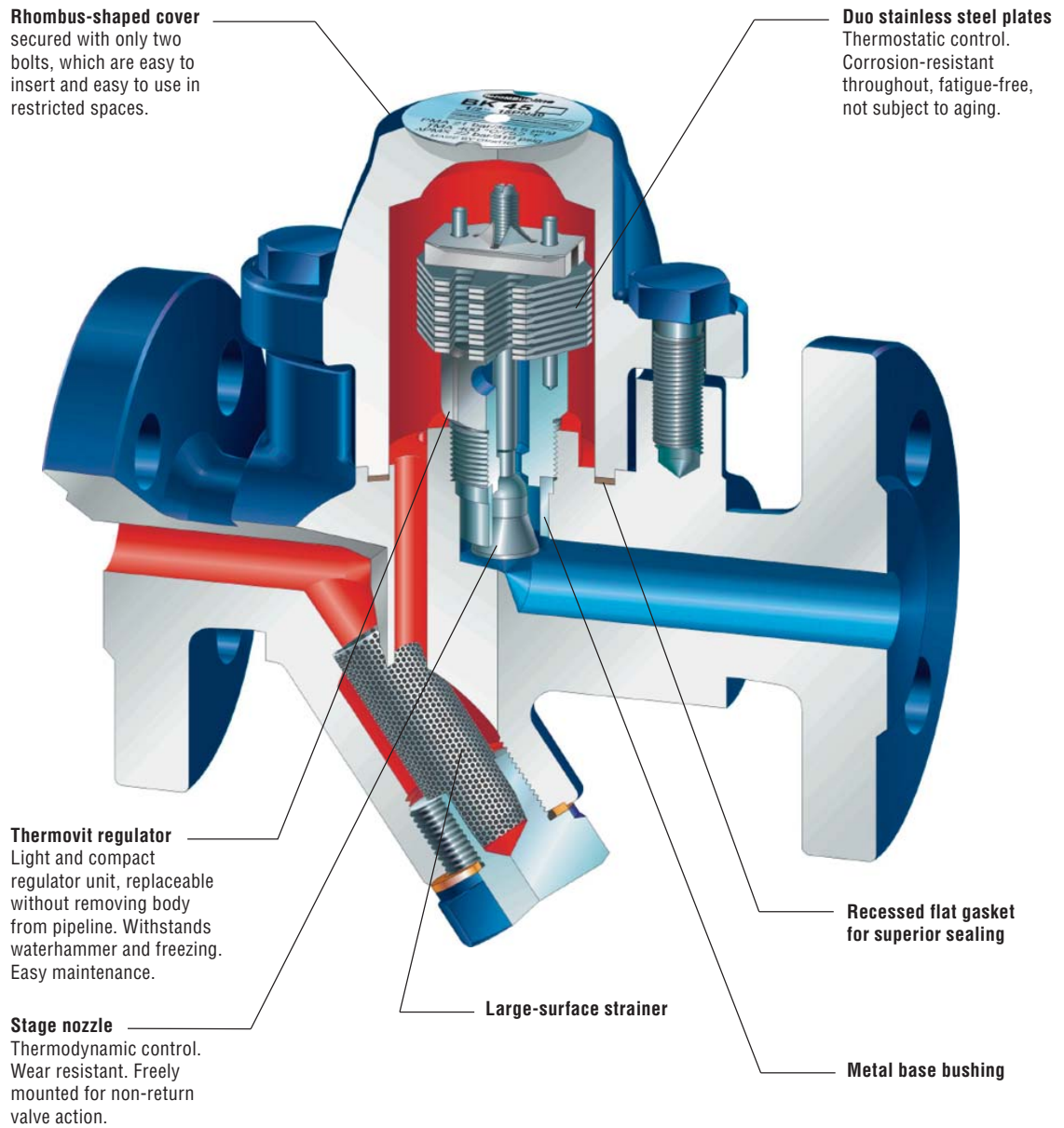
With rising condensate temperature, the plates deflect and draw the stage nozzle toward the closed position (a thermostatic process). The service pressure and the

pressure built up in the stage-nozzle chamber by flashing produce an opposite force (a thermodynamic process). The orifice area is determined by the prevailing state of equilibrium between the temperature-dependent closing force and the pressure-related opening force. Immediately below saturation temperature (boiling temperature), the plates are deflected to such an extent that the stage nozzle is almost closed. As a consequence the pressure in the stage-nozzle chamber decreases and breaks down as the flashing across the stage nozzle then closes.

The deflection of the Duo stainless steel plates created by the temperature is not sufficient to produce, over the complete pressure range, the force required to counteract the force acting on the stage nozzle in the opening direction. The plates are therefore arranged in a stack, which acts as a spring having a characteristic that adapts itself to the force acting on the stage nozzle, varying with the service pressure.

Thermostatic and spring characteristics are balanced so that the opening and closing temperatures are always just a few degrees below saturation temperature.





# Gestra® Steam Trap • Thermostatic Steam Trap

**BK 36/A7**

**465**  
psi  
Maximum Δp  
(32 bar)

**Class Rating:** ANSI 300

**Available Sizes:** 1/2", 3/4" and 1"  
(DN 15, 20 and 25)

### Application

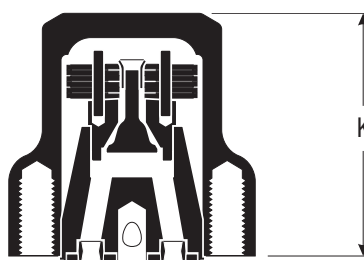
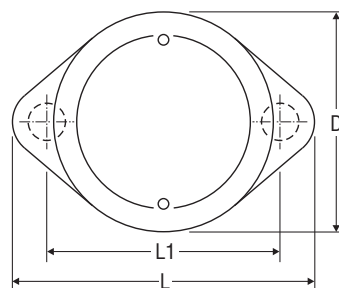
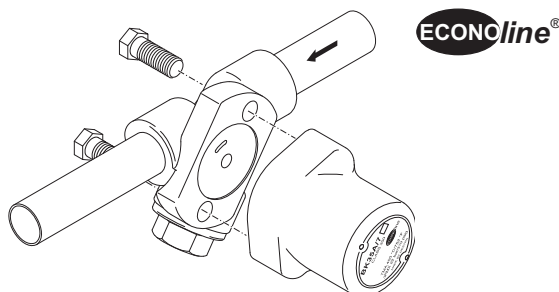
The **ECONoline®** BK 36/A7 steam trap is used for low capacity applications such as drip and tracing. The trap is attached to the universal connector by means of 2 hex head bolts and can be used on any existing connectors in your piping system.

### Features and Benefits

- Pressure assisted fail-open design.
- Discharges hot condensate at approximately **18°F** (10°C) below saturation temperature throughout its operating range. One internal regulator for all pressure ranges.
- Unaffected by water hammer or superheat - solid stainless steel internals.
- Self draining – will not freeze when installed in gravity drainage position.
- Automatically vents air and non-condensable gases and has a high **(9:1)** cold water capacity for rapid start-up.
- Operates with **zero steam loss** throughout its operating range saving steam and money during the life of the trap.
- Can be installed in any position.
- Two (2) year guarantee.

### Materials

- Cover – A351-CF8M (DIN 1.4408)
- Cover Bolts – ASTM A193-B7 (DIN 1.7225)
- Regulator – Stainless Steels
- Other Internals – Stainless Steel
- Connector – A351-CF8M (DIN 1.4408)



Dimensions and Weights		End Connections		
		Screwed / Socket Weld		
Nominal Sizes	[inch] [mm]	1/2 15	3/4 20	1 25
Dimensions	D [inch] [mm]	1.9 49		
	L [inch] [mm]	2.6 66		
	L1 [inch] [mm]	2.0 51		
	H [inch] [mm]	2.6 65		
Approx. Weight w/o connector	[lbs] [kg]	1.5 0.7		
Approx. Weight with connector	[lbs] [kg]	4.2 1.9	4.0 1.8	3.7 1.7

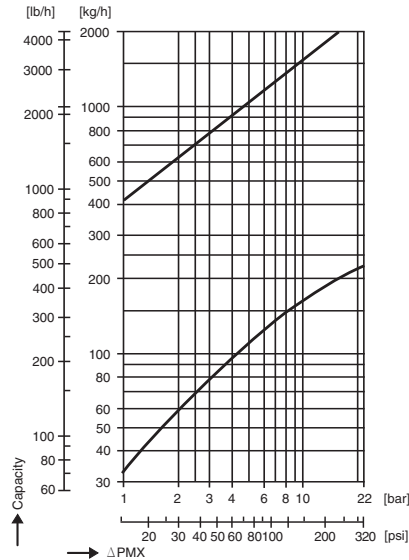
**465**  
psi  
Maximum  $\Delta p$   
(32 bar)

**Gestra® Steam Trap •  
Thermostatic Steam Trap**

**BK 36/A7**

**Class Rating:** ANSI 300

**Available Sizes:** ½", ¾" and 1"  
(DN 15, 20 and 25)



**Capacity Charts**

The chart shows the maximum capacities for hot and cold condensate. The capacities are a function of differential pressure or the difference between inlet and outlet pressures for the trap.

Curve 1 shows the maximum capacity when discharging hot condensate that is **18°F (10°C)** below steam saturation temperature. For example, at a differential pressure of **100 psi** the maximum hot capacity is approximately **290 lb/h**.

Curve 2 shows the maximum capacity when discharging cold condensate at a temperature of **68°F (20°C)**. For example, at a differential pressure of **100 psi** the maximum cold capacity is approximately **2,500 lb/h**.

**Available End Connections**

Screwed sockets: NPT, BSP

Socket-weld

Butt weld

**How to Order**

For the trap only:

BK 36/A7

For the trap and connector:

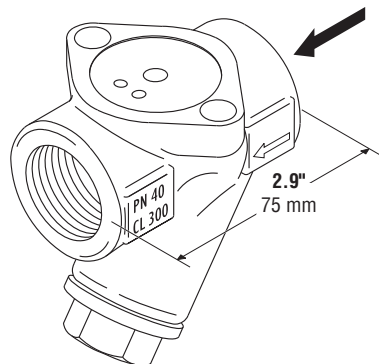
Specify trap, end connection size and type.

For Example: BK 35/A7 ½" NPT.

Add "w/BOV" if blow-off valve is desired.

Pressure / Temperature Ratings						
Maximum Service Pressure	[psig]	719	613	519	458	421
	[barg]	49.6	42.3	35.8	31.6	29
Related Temperature	[°F]	68	212	392	572	842
	[°C]	20	100	200	300	450
Maximum Differential Pressure	<b>465 psig (32 barg)</b>					

Flowserve Gestra Universal Connector



# Gestra® Steam Trap • Thermostatic Steam Trap

**BK 45**

**320**  
psi  
Maximum Δp  
(22 bar)

**Class Rating:** ANSI 300

**Available Sizes:** 1/2", 3/4" and 1"  
(DN 15, 20 and 25)

### Application

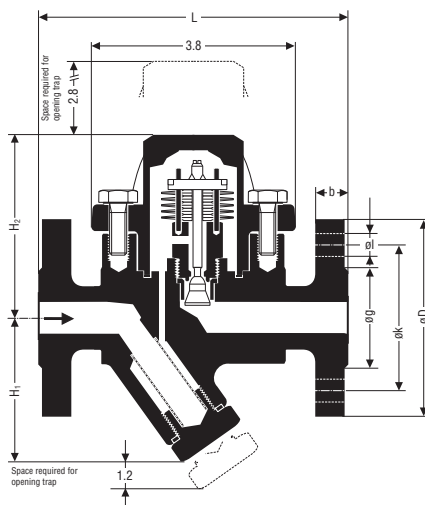
The **RHOMBUSline®** BK 45 steam trap is used for low capacity applications such as drip and tracing, and economically combines steam trap, check valve and Y-Strainer (with optional blow off valve) in a small profile with a convenient 2-bolt cover for easy maintenance.

### Features and Benefits

- Forged steel body and cover.
- Pressure assisted fail-open design.
- Factory-preset bimetallic regulator with integral staged nozzle. No adjustment required.
- Discharges hot condensate in a modulating fashion at approximately **18°F (10°C)** below saturation temperature throughout its operating range. One internal regulator for all pressure ranges.
- Unaffected by water hammer or superheat-solid stainless steel internals.
- Self draining – will not freeze when installed in gravity drainage position.
- Automatically vents air and non-condensable gases and has a high (**6:1**) cold water capacity for rapid start-up.
- Operates with **zero steam loss** throughout its operating range saving steam and money during the life of the trap.
- Easy in-line inspection and maintenance – mechanical stops prevent crushing of the gasket for extended gasket life.
- Can be installed in any position.
- Internal stainless steel **Y**-strainer, with optional blowoff valve.
- Integral check valve design.
- Two (2) year guarantee.

### Materials

- Body and Cover – ASTM A105 (DIN 1.0460)
- Cover Bolts – ASTM A193 B7 (DIN 1.7258)
- Bimetallic Regulator – Stainless Steels
- Other Internals – Stainless Steel



Pressure / Temperature Ratings				
Maximum Service Pressure	[psig]	464	319	305
	[barg]	32	22	21
Related Temperature	[°F]	482	725	752
	[°C]	250	385	400
Maximum Differential Pressure		320 psig (22 barg)		

Dimensions and Weights		End Connections								
		Flanged			Screwed Socket-Weld			Butt-Weld		
Nominal Sizes	[inch] [mm]	1/2 15	3/4 20	1 25	1/2 15	3/4 20	1 25	1/2 15	3/4 20	1 25
Dimensions	L [inch] [mm]	5.9 150	5.9 150	6.3 160	3.7 95			7.9 200		
	H1 [inch] [mm]	2.8 70			2.8 70			2.8 70		
	H2 [inch] [mm]	2.4 62			2.4 62			2.4 62		
Approx. Weight	[lbs] [kg]	8.1 3.7	9.5 4.3	10.6 4.8	4.8 2.2	4.6 2.1	4.4 2	5.5 2.5	5.5 2.5	5.5 2.5

Flange Dimensions	End Connections											
	DIN			CL 150			CL 300					
D [inch] [mm]	3.7 95	4.1 105	4.5 115	3.5 88.9	3.9 98.4	4.2 107.9	3.7 95.2	4.6 117.5	4.6 117.5	4.9 123.8		
b [inch] [mm]	0.6 16	0.7 18	0.7 18	0.4 11.1	0.5 12.7	0.6 14.3	0.6 14.3	0.6 15.9	0.6 15.9	0.7 17.5		
k [inch] [mm]	2.6 65	3 75	3.3 85	2.4 60.3	2.7 68.8	3.1 79.4	2.6 66.7	3.2 82.5	3.2 82.5	3.5 88.9		
g [inch] [mm]	1.8 45	2.3 58	2.7 68	1.4 34.9	1.7 42.9	2 50.8	1.4 34.9	1.7 42.9	1.7 42.9	2 50.8		
l [inch] [mm]	0.6 14	0.6 14	0.6 14	0.6 14	0.6 15.9	0.6 15.9	0.6 15.9	0.7 19	0.7 19	0.7 19		
Number of bolts	4	4	4	4	4	4	4	4	4	4		

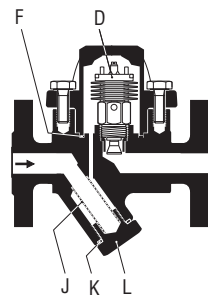
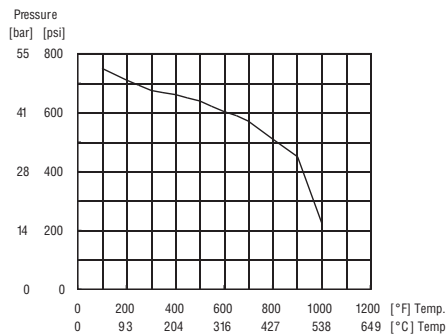
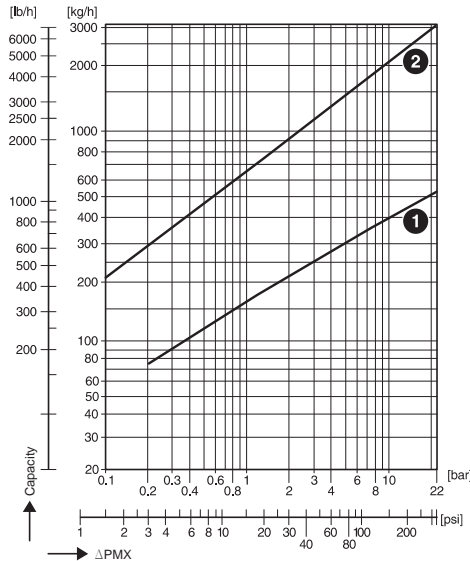
**320**  
psi  
Maximum  $\Delta p$   
(22 bar)

## Gestra® Steam Trap • Thermostatic Steam Trap

**BK 45**

**Class Rating:** ANSI 300

**Available Sizes:** ½", ¾" and 1"  
(DN 15, 20 and 25)



Standard Spare Parts			
Item Number	Description	BK 45	BK 45U
D, F	Complete Regulator including cover gasket	375234	375235
J, K, L	Complete Strainer set	375113	375113

### Capacity Charts

The chart shows the maximum capacities for hot and cold condensate as a function of differential pressure or the difference between inlet and outlet pressures for the trap.

Curve 1 shows the maximum capacity when discharging hot condensate that is **18°F (10°C)** below steam saturation temperature. For example, at a differential pressure of **100 psi**, the maximum hot capacity is approximately **770 lb/hr.**

Curve 2 shows the maximum capacity when discharging cold condensate at a temperature of **68°F (20°C)**. For example, at a differential pressure of **100 psi**, the maximum cold capacity is approximately **4,200 lb/hr.**

### Temperature Discharge Options

Special factory adjustment of the regulator for increased undercooling is available for open discharge applications where sensible heat savings and flash steam suppression are desirable. Please contact your Flowserve Gestra representative for more details.

### Body Pressure/Temperature Ratings

The curve shows the maximum shell (body) pressure and temperature ratings. Operating differential pressure of the regulator is limited to **320 psi**.

### Material/Test Certificates

All inspection requirements must be stated at time of order. Test certificates can be issued on request in accordance with EN 10204 – 2.2 and -3.1B. Body and Cover heat codes are required.

### Available End Connections

Flanges: ANSI 150RF and 300RF (DIN, PN 40)

Screwed sockets: NPT, BSP

Socket-weld, Butt weld

### How to Order

Specify trap, end connection size and type.

Add "w/BOV" if optional blow off valve is desired.

For example: BK 45 ½" NPT w/BOV

**NOTE:** If ANSI flanged ends are required, please specify either ANSI 150 RF or ANSI 300 RF.



# Gestra® Steam Trap • Thermostatic Steam Trap

**BK 46**

465

psi  
Maximum Δp  
(32 bar)

**Class Rating:** ANSI 300

**Available Sizes:** 1/2", 3/4" and 1"  
(DN 15, 20 and 25)

**Application**

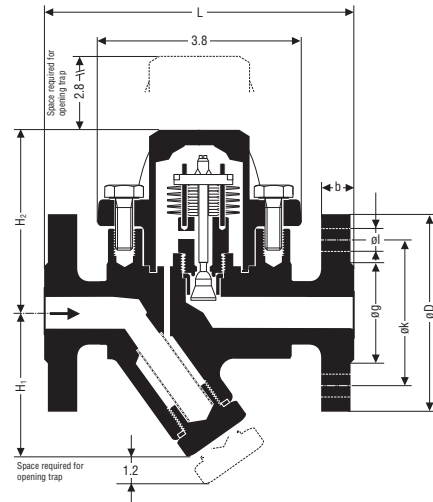
The **RHOMBUSline®** BK 46 steam trap is used for low capacity applications such as drip and tracing, and economically combines steam trap, check valve and Y-Strainer (with optional blow off valve) in a small profile with a convenient 2-bolt cover for easy maintenance.

**Features and Benefits**

- Forged steel body and cover.
- Pressure assisted fail-open design.
- Factory-preset bimetallic regulator with integral staged nozzle. No adjustment required.
- Discharges hot condensate in a modulating fashion at approximately **18°F (10°C)** below saturation temperature throughout its operating range. One internal regulator for all pressure ranges.
- Unaffected by water hammer or superheat-solid stainless steel internals.
- Self draining – will not freeze when installed in gravity drainage position.
- Automatically vents air and non-condensable gases and has a high (**5:1**) cold water capacity for rapid start-up.
- Operates with **zero steam loss** throughout its operating range saving steam and money during the life of the trap.
- Easy in-line inspection and maintenance – mechanical stops prevent crushing of the gasket for extended gasket life.
- Can be installed in any position.
- Internal stainless steel Y-strainer, with optional blowoff valve.
- Integral check valve design.
- Two (2) year guarantee.

**Materials**

- Body and Cover – ASTM A182 F12 (DIN 1.5415)
- Cover Bolts – ASTM A193 B7 (DIN 1.7258)
- Bimetallic Regulator – Stainless Steels
- Other Internals – Stainless Steel



Pressure / Temperature Ratings				
Maximum Service Pressure	[psig]	<b>508</b>	<b>464</b>	<b>406</b>
	[barg]	35	32	28
Related Temperature	[°F]	<b>572</b>	<b>635</b>	<b>842</b>
	[°C]	300	335	450
Maximum Differential Pressure	<b>465 psig (32 barg)</b>			

Dimensions and Weights		End Connections								
		Flanged			Screwed Socket-Weld			Butt-Weld		
		1/2	3/4	1	1/2	3/4	1	1/2	3/4	1
Nominal Sizes	[inch] [mm]	15 15	20 20	25 25	15 15	20 20	25 25	15 15	20 20	25 25
Dimensions	L [inch] [mm]	5.9 150	5.9 150	6.3 160	3.7 95			7.9 200		
	H1 [inch] [mm]	2.8 70			2.8 70			2.8 70		
	H2 [inch] [mm]	2.4 62			2.4 62			2.4 62		
Approx. Weight	[lbs] [kg]	8.1 3.7	9.5 4.3	10.6 4.8	4.8 2.2	4.6 2.1	4.4 2	5.5 2.5	5.5 2.5	5.5 2.5

Flange Dimensions	End Connections								
	DIN			CL 150			CL 300		
D [inch] [mm]	3.7 95	4.1 105	4.5 115	3.5 88.9	3.9 98.4	4.2 107.9	3.7 95.2	4.6 117.5	4.9 123.8
b [inch] [mm]	0.6 16	0.7 18	0.7 18	0.4 11.1	0.5 12.7	0.6 14.3	0.6 14.3	0.6 15.9	0.7 17.5
k [inch] [mm]	2.6 65	3 75	3.3 85	2.4 60.3	2.7 69.8	3.1 79.4	2.6 66.7	3.2 82.5	3.5 88.9
g [inch] [mm]	1.8 45	2.3 58	2.7 68	1.4 34.9	1.7 42.9	2 50.8	1.4 34.9	1.7 42.9	2 50.8
l [inch] [mm]	0.6 14	0.6 14	0.6 14	0.6 15.9	0.6 15.9	0.6 15.9	0.6 15.9	0.7 19	0.7 19
Number of bolts	4	4	4	4	4	4	4	4	4

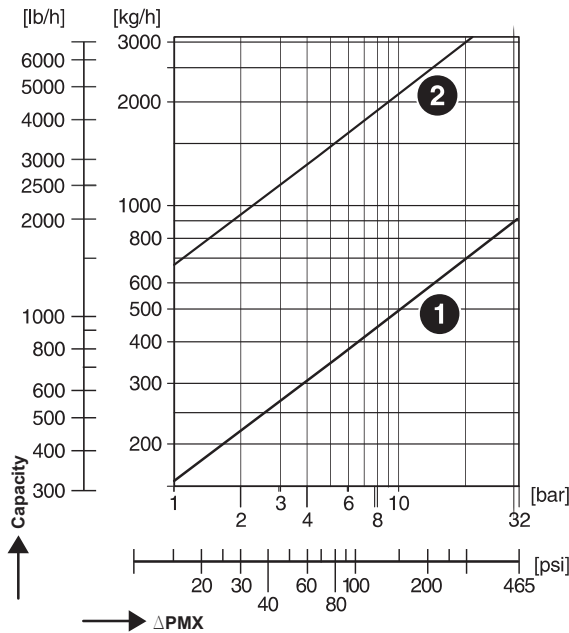
**465**  
psi  
Maximum  $\Delta p$   
(32 bar)

**Gestra® Steam Trap •  
Thermostatic Steam Trap**

**BK 46**

**Class Rating:** ANSI 300

**Available Sizes:** ½", ¾" and 1"  
(DN 15, 20 and 25)



**Capacity Charts**

The chart shows the maximum capacities for hot and cold condensate as a function of differential pressure or the difference between inlet and outlet pressures for the trap.

Curve 1 shows the maximum capacity when discharging hot condensate that is **18°F (10°C)** below steam saturation temperature. For example, at a differential pressure of **100 psi**, the maximum hot capacity is approximately **830 lb/hr.**

Curve 2 shows the maximum capacity when discharging cold condensate at a temperature of **68°F (20°C)**. For example, at a differential pressure of **100 psi**, the maximum cold capacity is approximately **4,000 lb/hr.**

**Temperature Discharge Options**

Special factory adjustment of the regulator for increased undercooling is available for open discharge applications where sensible heat savings and flash steam suppression are desirable. Please contact your Flowserve Gestra representative for more details.

**Body Pressure/Temperature Ratings**

The curve shows the maximum shell (body) pressure and temperature ratings. Operating differential pressure of the regulator is limited to **465 psi.**

**Material/Test Certificates**

All inspection requirements must be stated at time of order. Test certificates can be issued on request in accordance with EN 10204 – 2.2 and -3.1B. Body and Cover heat codes are required.

**Available End Connections**

Flanges: ANSI 150RF and 300RF (DIN, PN 40)

Screwed sockets: NPT, BSP

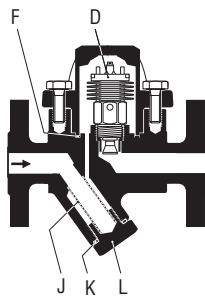
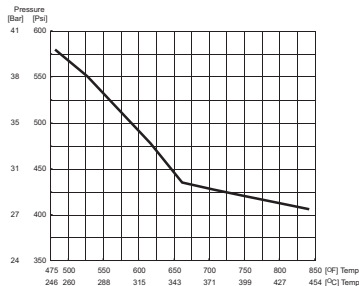
Socket-weld, Butt weld

**How to Order**

Specify trap, end connection size and type.

For example: BK 46 ½" NPT

**NOTE:** If ANSI flanged ends are required, please specify either ANSI 150 RF or ANSI 300 RF.



Standard Spare Parts		
Item Number	Description	BK 46
D, F	Complete Regulator including cover gasket	375464
J, K, L	Complete Strainer set	375113

# Gestra® Steam Trap • Thermostatic Steam Trap

**BK 37**

**652**  
psi  
Maximum Δp  
(45 bar)

**Class Rating:** ANSI 600

**Available Sizes:** 1/2", 3/4" and 1"  
(DN 15, 20 and 25)

### Application

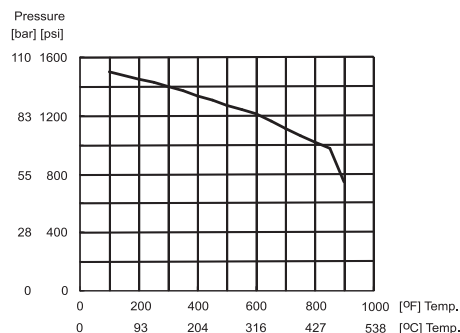
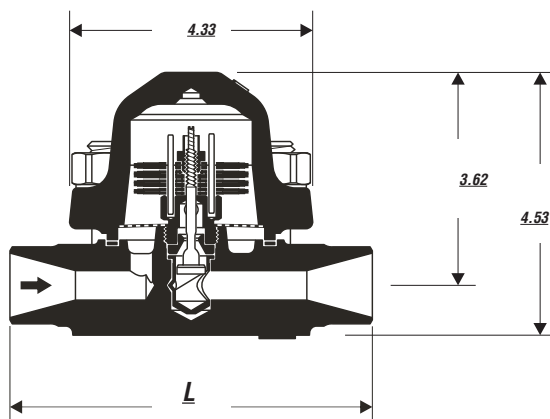
The BK 37 is designed for high pressure drip applications including: steam main drip, turbine drain, etc. Excellent for superheated steam drip applications.

### Features and Benefits

- Forged alloy steel body with thick Titanium Body Shield to resist flashing damage.
- Titanium alloy valve and seat.
- Pressure assisted “fail open-only” design.
- Standard factory setting discharges hot condensate in a modulating fashion at approximately **18°F (10°C)** below saturation temperatures throughout its operating range.
- One internal bimetallic regulator for all applicable body pressure ranges. Single replacement part.
- Staged “control valve-style” nozzle reduces wiredrawing damage by reducing flashing. Totally unaffected by water hammer.
- Self draining – will not freeze when installed in gravity drainage position. Can be installed in any position.
- Automatically vents air and non-condensable gases and has a very high (7:1) cold water capacity for rapid start-up.
- Operates with **zero steam loss** throughout its operating range saving steam and money during the life of the trap.
- Easy in-line inspection and maintenance – no need to remove the trap from the piping to clean or replace the internals.
- Internal stainless steel strainer.
- Integral check valve design.
- Two (2) year guarantee.

### Materials

- Body and Cover – ASTM-A182 F12
- Body Insert – Titanium
- Cover Bolts – ASTM A193 B7
- Bimetallic Regulator – SST Steels and Titanium
- Other Internals – Stainless Steel



Pressure / Temperature Ratings			
Maximum Service Pressure	[psig]	1400	1210
	[barg]	97	83
Related Temperature	[°F]	300	600
	[°C]	149	316
Maximum Differential Pressure		652 psig (45 barg)	

Dimensions and Weights		End Connections								
		Flanged			Screwed Socket-Weld			Butt-Weld		
Nominal Sizes	[inch] [mm]	1/2 15	3/4 20	1 25	1/2 15	3/4 20	1 25	1/2 15	3/4 20	1 25
Dimensions	L [inch] [mm]	9.1 230			6.3 160			6.3 160		
Approx. Weight	[lbs]	15.4	19.8	19.8	11.2			11.2		
	[kg]	7	9	9	5.1			5.1		

**652**

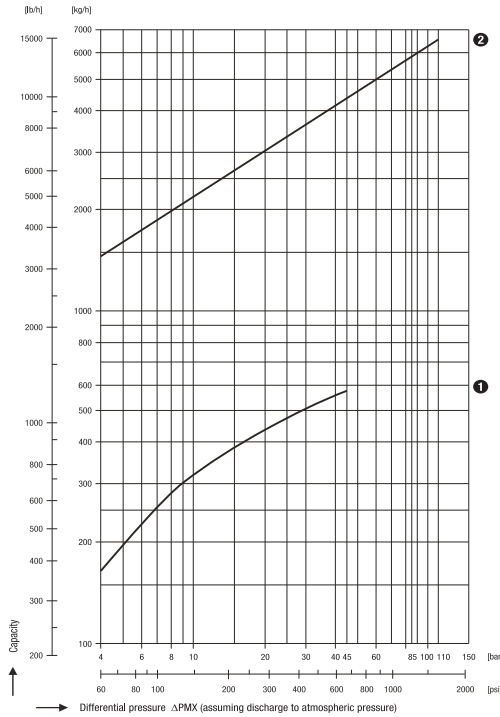
psi  
Maximum  $\Delta p$   
(45 bar)

**Gestra® Steam Trap •  
Thermostatic Steam Trap**

**BK 37**

**Class Rating:** ANSI 600

**Available Sizes:** ½", ¾" and 1"  
(DN 15, 20 and 25)



**Capacity Charts**

The chart shows the maximum capacities for hot and cold condensate. The capacities are a function of differential pressure or the difference between inlet and outlet pressures for the trap.

Curve 1 shows the maximum capacity when discharging hot condensate that is **18°F (10°C)** below steam saturation temperature. For example, at a differential pressure of **400 psi** the maximum hot capacity is approximately **1,060 lb/hr**.

Curve 2 shows the maximum capacity when discharging cold condensate at a temperature of **68°F (20°C)**. For example, at a differential pressure of **400 psi** the maximum cold capacity is approximately **7,700 lb/hr**.

**Temperature Discharge Options**

Special factory adjustment of the regulator for increased undercooling is available for open discharge applications where sensible heat savings and flash steam suppression are desirable. Additionally, the regulator can also be adjusted for hotter discharge (less subcooling) if required. Please contact your local Gestra representative for more details.

**Body Pressure/Temperature Ratings**

The curve shows the maximum shell (body) pressure and temperature rating. Operating differential pressure is limited to **652 psi (45 bar)**.

**Material/Test Certificates**

All inspection requirements must be stated at time of order. Test certificates can be issued upon request in accordance with EN 10204 – 2.2 and -3.1B. Heat codes from Body and Cover are required.

**Available End Connections**

NPT

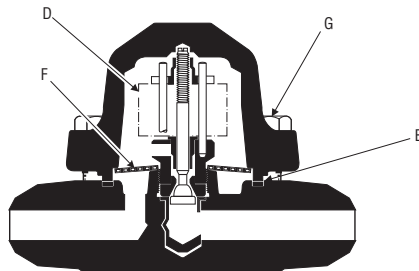
Flanges: ANSI 600

Socket-weld, Butt weld

**How to Order**

Specify trap, end connection size and type.

For Example: BK 37 ½" SW



Standard Spare Parts		
Item Number	Description	BK 37
D	Regulator	377722
E	Cover Gasket	372095
F	Strainer	096701
G	Cover Bolt	013644
H	Nuts (not shown)	013574

# Gestra® Steam Trap • Thermostatic Steam Trap

**BK 28**

**1230**  
psi  
Maximum Δp  
(85 bar)

**Class Rating:** ANSI 600

**Available Sizes:** 1/2", 3/4" and 1"  
(DN 15, 20 and 25)

**Application**

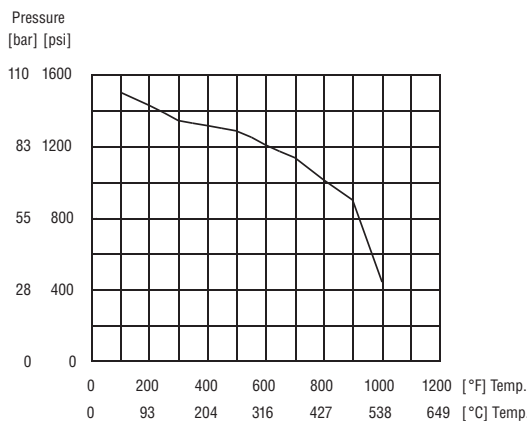
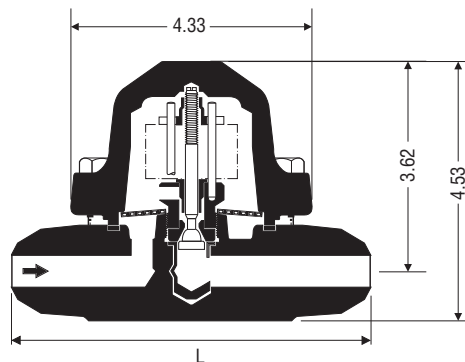
The BK 28 is designed for high pressure drip applications including: steam main drip, turbine drain, etc. Excellent for superheated steam drip applications.

**Features and Benefits**

- Forged alloy steel body with thick Titanium Body Shield to resist flashing damage.
- Titanium alloy valve and seat.
- Pressure assisted “fail open-only” design.
- Standard factory setting discharges hot condensate in a modulating fashion at approximately **18°F (10°C)** below saturation temperatures throughout its operating range.
- One internal bimetallic regulator for all applicable body pressure ranges. Single replacement part.
- Staged “control valve-style” nozzle reduces wiredrawing damage by reducing flashing. Totally unaffected by water hammer.
- Self draining – will not freeze when installed in gravity drainage position. Can be installed in any position.
- Automatically vents air and non-condensable gases and has a very high (7:1) cold water capacity for rapid start-up.
- Operates with **zero steam loss** throughout its operating range saving steam and money during the life of the trap.
- Easy in-line inspection and maintenance – no need to remove the trap from the piping to clean or replace the internals.
- Internal stainless steel strainer.
- Integral check valve design.
- Two (2) year guarantee.

**Materials**

- Body and Cover – ASTM-A182 F12
- Body Insert – Titanium
- Cover Bolts – ASTM A193 B7 (DIN 1.7258)
- Bimetallic Regulator – SST Steels and Titanium
- Other Internals – Stainless Steel



Pressure / Temperature Ratings			
Maximum Service Pressure	[psig]	1233	972
	[barg]	85	67
Related Temperature	[°F]	572	842
	[°C]	300	450
Maximum Differential Pressure	1230 psig (85 barg)		

Dimensions and Weights		End Connections								
		Flanged			Screwed Socket-Weld			Butt-Weld		
Nominal Sizes	[inch] [mm]	1/2 15	3/4 20	1 25	1/2 15	3/4 20	1 25	1/2 15	3/4 20	1 25
Dimensions	L [inch] [mm]	9.1 230			6.3 160			6.3 160		
Approx. Weight	[lbs] [kg]	13.9 6.3	15.8 7.2	15.8 7.2	11.9 5.4			11.2 5.1		

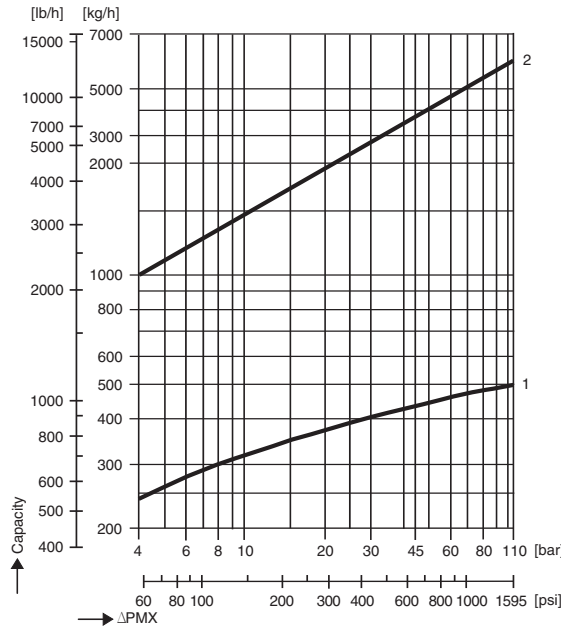
**1230**  
psi  
Maximum  $\Delta p$   
(85 bar)

**Gestra® Steam Trap •  
Thermostatic Steam Trap**

**BK 28**

**Class Rating:** ANSI 600

**Available Sizes:** ½", ¾" and 1"  
(DN 15, 20 and 25)



**Capacity Charts**

The chart shows the maximum capacities for hot and cold condensate. The capacities are a function of differential pressure or the difference between inlet and outlet pressures for the trap.

Curve 1 shows the maximum capacity when discharging hot condensate that is **18°F (10°C)** below steam saturation temperature. For example, at a differential pressure of **650 psi** the maximum hot capacity is approximately **900 lb/hr.**

Curve 2 shows the maximum capacity when discharging cold condensate at a temperature of **68°F (20°C)**. For example, at a differential pressure of **650 psi** the maximum cold capacity is approximately **9,000 lb/hr.**

**Temperature Discharge Options**

Special factory adjustment of the regulator for increased undercooling is available for open discharge applications where sensible heat savings and flash steam suppression are desirable. Additionally, the regulator can also be adjusted for hotter discharge (less subcooling) if required. Please contact your local Gestra representative for more details.

**Body Pressure/Temperature Ratings**

The curve shows the maximum shell (body) pressure and temperature rating. Operating differential pressure is limited to **1,230 psi (85 bar)**.

**Material/Test Certificates**

All inspection requirements must be stated at time of order. Test certificates can be issued upon request in accordance with EN 10204 – 2.2 and -3.1B. Heat codes from Body and Cover are required.

**Available End Connections**

NPT, BSP

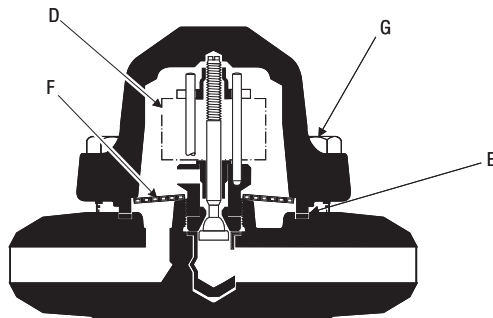
Flanges: ANSI 600 (DIN PN 40)

Socket-weld, Butt weld

**How to Order**

Specify trap, end connection size and type.

For Example: BK 28 ½" SW



Standard Spare Parts		
Item Number	Description	BK 37
D	Regulator	377722
E	Cover Gasket	372095
F	Strainer	096701
G	Cover Bolt	013644
H	Nuts (not shown)	013574

# Gestra® Steam Trap • Thermostatic Steam Trap

**BK 29**

**1600**  
psi  
Maximum Δp  
(110 bar)

**Class Rating:** ANSI 900

**Available Sizes:** 1/2", 3/4" and 1"  
(DN 15, 20 and 25)

**Application**

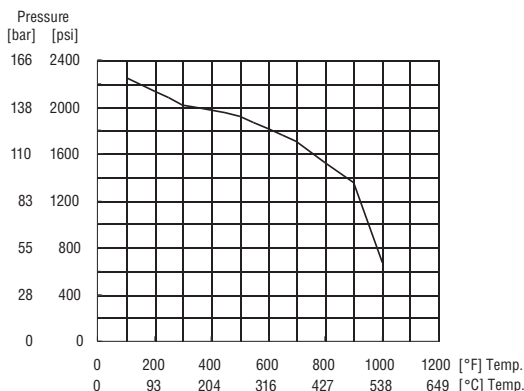
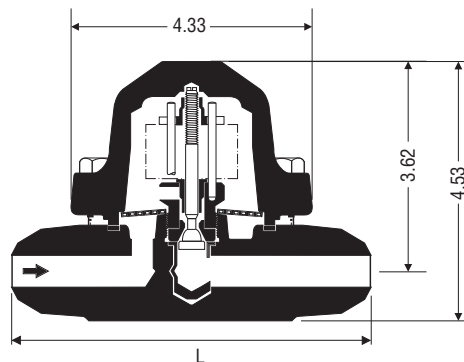
The BK 29 is designed for high pressure drip applications including steam main drip, turbine protection drain, etc. Excellent for superheated steam drip applications.

**Features and Benefits**

- Forged alloy steel body with Titanium body shield to resist flashing damage.
- Titanium alloy valve and seat.
- Pressure assisted “fail open-only” design.
- Standard factory setting discharges hot condensate in a modulating fashion at approximately **18°F (10°C)** below saturation temperatures throughout its operating range.
- One internal bimetallic regulator for all applicable body pressure ranges.
- Staged “control valve-style” nozzle reduces wiredrawing damage by reducing flashing. Totally unaffected by water hammer.
- Self draining – will not freeze when installed in gravity drainage position. Can be installed in any position.
- Automatically vents air and non-condensable gases and has a very high (>7:1) cold water capacity for rapid start-up.
- Operates with **zero steam loss** throughout its operating range saving steam and money during the life of the trap.
- Easy in-line inspection and maintenance – no need to remove the trap from the piping to clean or replace the internals.
- Valve and seat are a single, modular replacement part.
- Internal stainless steel strainer.
- Integral check valve design.
- Two (2) year guarantee.

**Materials**

- Body and Cover – A182 F12 (DIN 1.5415 )
- Cover Bolts – ASTM A193 B7 (DIN 1.7709)
- Bimetallic Regulator – Stainless Steel and Titanium
- Other Internals – Stainless Steel



Pressure / Temperature Ratings			
Maximum Service Pressure	[psig]	1595	667
	[barg]	110	46
Related Temperature	[°F]	752	1004
	[°C]	400	540
Maximum Differential Pressure		1595 psig (110 barg)	

Dimensions and Weights		End Connections								
		Flanged			Screwed Socket-Weld			Butt-Weld		
Nominal Sizes	[inch] [mm]	1/2 15	3/4 20	1 25	1/2 15	3/4 20	1 25	1/2 15	3/4 20	1 25
Dimensions	L [inch] [mm]	9.1 230	9.1 230	10 254	7.9 200			7.9 200		
Approx. Weight	[lbs]	15.6	17.6	17.6	13.6			13.6		
	[kg]	7.1	8	8	6.2			6.2		

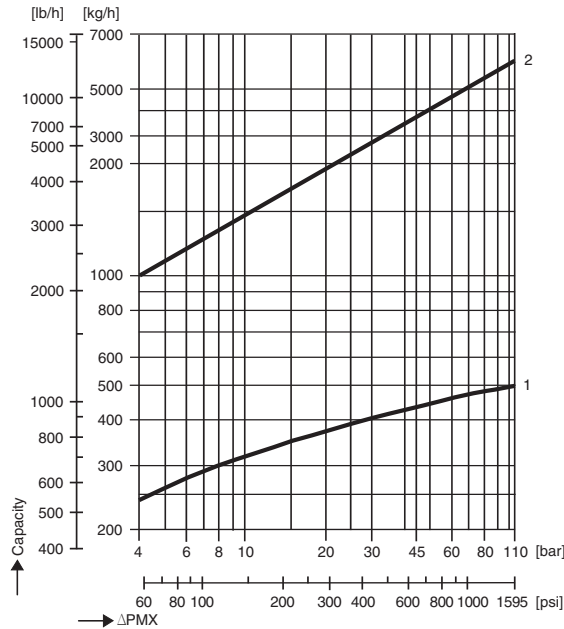
**1600**  
psi  
Maximum  $\Delta p$   
(110 bar)

**Gestra® Steam Trap •  
Thermostatic Steam Trap**

**BK 29**

**Class Rating:** ANSI 900

**Available Sizes:** ½", ¾" and 1"  
(DN 15, 20 and 25)



**Capacity Charts**

The charts show the maximum capacities for hot and cold condensate. The capacities are a function of differential pressure or the difference between inlet and outlet pressures for the trap.

Curve 1 shows the maximum capacity when discharging hot condensate that is **18°F (10°C)** below steam saturation temperature. For example, at a differential pressure of **500 psi** the maximum hot capacity is approximately **1,000 lb/hr.**

Curve 2 shows the maximum capacity when discharging cold condensate at a temperature of **68°F (20°C)**. For example, at a differential pressure of **500 psi** the maximum cold capacity is approximately **7,000 lb/hr.**

**Temperature Discharge Options**

Special factory adjustment of the regulator for increased undercooling is available for open discharge applications where sensible heat savings and flash steam suppression are desirable. Additionally, the regulator can be adjusted for hotter (less subcooling) discharge when required. Please contact your local Flowserve Gestra representative for more details.

**Body Pressure/Temperature Ratings**

The curve shows the maximum shell (body) pressure and temperature rating. Operating differential pressure is limited to **1,595 psi (110 bar).**

**Material/Test Certificates**

Test certificates can be issued on request in accordance with EN 10204 – 2.2 and -3.1B. Heat Codes from Body and Cover are required.

**Available End Connections**

Flanges: ANSI 900/1500 (DIN PN)

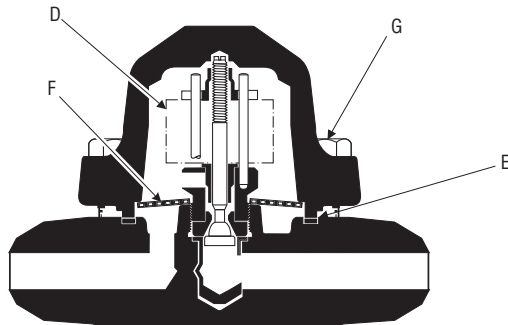
Socket-weld, Butt weld

**How to Order**

Specify trap, end connection size and type.

For Example: BK 29 ½" Socketweld

If ANSI flanged ends required, specify either ANSI 900 RF or ANSI 1500 RF.



Standard Spare Parts		
Item Number	Description	BK 29
D	Regulator	370281
E	Cover Gasket	372095
F	Strainer	096701
G	Cover Bolts	014231
H	Nuts (not shown)	010746



# Gestra® Steam Trap • Thermostatic Steam Trap

**BK 212**

**3625**  
psi  
Maximum Δp  
(250 bar)

**Class Rating:** ANSI 2500

**Available Sizes:** 1/2", 3/4" and 1"  
(DN 15, 20 and 25)

### Application

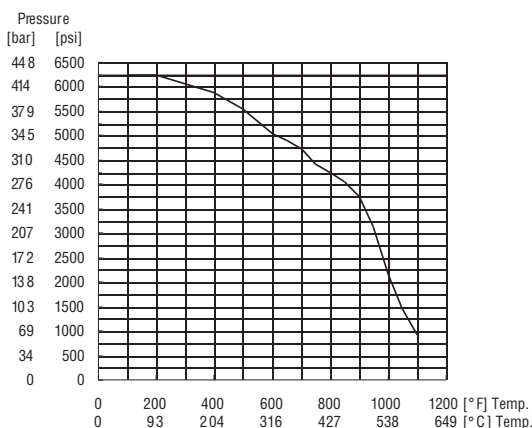
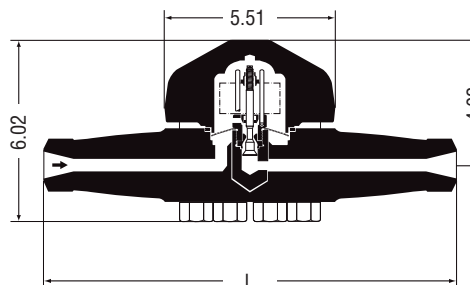
The BK 212 is designed for high pressure drip applications including: steam main drip, turbine protection drain, etc. Excellent for superheated steam drip applications.

### Features and Benefits

- Forged alloy steel body with Titanium body shield to resist flashing damage.
- Titanium alloy valve and seat.
- Pressure assisted “fail open-only” design.
- Standard factory setting discharges hot condensate in a modulating fashion at approximately **18°F (10°C)** below saturation temperatures throughout its operating range.
- One internal bimetallic regulator for all applicable body pressure ranges.
- Staged “control valve” style nozzle reduces wiredrawing damage by reducing flashing. Totally unaffected by water hammer.
- Self draining – will not freeze when installed in gravity drainage position. Can be installed in any position.
- Automatically vents air and non-condensable gases and has a very high (>9:1) cold water capacity for rapid start-up.
- Operates with **zero steam loss** throughout its operating range saving steam and money during the life of the trap.
- Easy in-line inspection and maintenance – no need to remove the trap from the piping to clean or replace the internals.
- Valve and seat are a single, modular replacement part.
- Internal stainless steel strainer.
- Integral check valve design.
- Two (2) year guarantee.

### Materials

- Body and Cover – ASTM A182 F22
- Cover Bolts – ASTM A193B7 (DIN 1.7258)
- Bimetallic Regulator – Stainless Steels
- Stage Nozzle and Seat Ring – Titanium
- Other Internals – Stainless Steel



Pressure / Temperature Ratings			
Maximum Service Pressure	[psig]	<b>3814</b>	<b>2639</b>
	[barg]	263	182
Related Temperature	[°F]	<b>887</b>	<b>977</b>
	[°C]	475	525
Maximum Differential Pressure		<b>3625 psig (250 barg)</b>	

Dimensions and Weights		End Connections								
		Flanged			Screwed Socket-Weld			Butt-Weld		
Nominal Sizes	[inch]	1/2	3/4	1	1/2	3/4	1	1/2	3/4	1
	[mm]	15	20	25	15	20	25	15	20	25
Dimensions	L [inch]	17.7	18.9	18.9	13			13		
	[mm]	450	480	480	330			330		
Approx. Weight	[lbs]	47.1	49.3	55.9	33.9			33.9		
	[kg]	21.4	22.4	25.4	15.4			15.4		

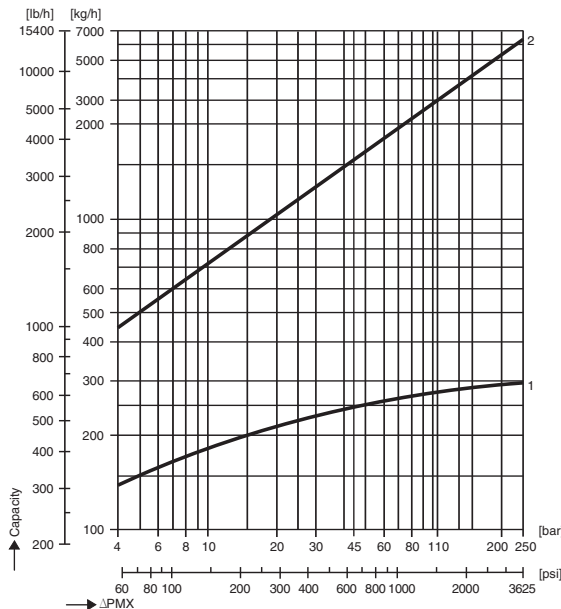
**3625**  
psi  
Maximum  $\Delta p$   
(250 bar)

## Gestra® Steam Trap • Thermostatic Steam Trap

**BK 212**

**Class Rating:** ANSI 2500

**Available Sizes:** ½", ¾" and 1"  
(DN 15, 20 and 25)



### Capacity Charts

The charts show the maximum capacities for hot and cold condensate. The capacities are a function of differential pressure or the difference between inlet and outlet pressures for the trap.

Curve 1 shows the maximum capacity when discharging hot condensate that is 18°F (10°C) below steam saturation temperature. For example, at a differential pressure of 1,000 psi (69 bar), the maximum hot capacity is approximately 600 lb/hr.

Curve 2 shows the maximum capacity when discharging cold condensate at a temperature of 68°F (20°C). For example, at a differential pressure of 1,000 psi (69 bar), the maximum cold capacity is approximately 4,800 lb/hr.

### Temperature Discharge Options

Special factory adjustment of the regulator for increased undercooling is available for open discharge applications where sensible heat savings and flash steam suppression are desirable. For more details, contact your Gestra representative.

### Body Pressure/Temperature Ratings

The curve shows the maximum shell (body) pressure and temperature rating. Operating differential pressure is limited to 3,625 psi.

### Material/Test Certificates

Test certificates can be issued on request in accordance with EN 10204 – 2.2 and -3.1B. Heat codes from Body and Cover are required.

### Available End Connections

Flanges: ANSI 2500RF

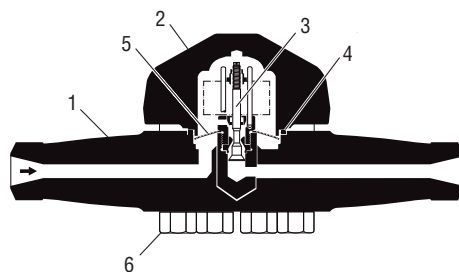
Socket-weld ends (Class 9000)

Butt-weld ends (Sch 160 or XXS)

### How to Order

Specify trap, end connection size and type.

For Example: BK 212 ½" Socketweld



Standard Spare Parts		
Item Number	Description	BK 212
1	Body	
2	Cover	089456
3	Regulator	371862
4	Cover Gasket	374009
5	Strainer	096345
6	Cover Bolts	089342

# Gestra® Steam Trap • Thermostatic Steam Trap

## BK 212HT

**3625**  
psi  
Maximum Δp  
(250 bar)

**Class Rating:** PN 630

**Available Sizes:** 1/2", 3/4" and 1"  
(DN 15, 20 and 25)

### Application

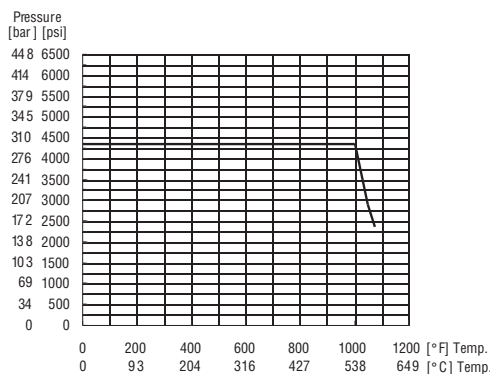
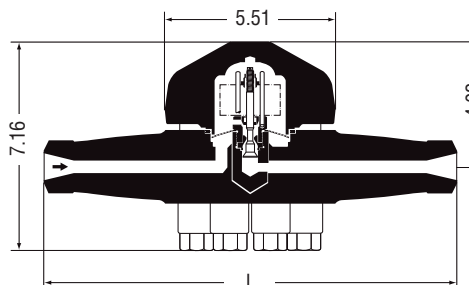
The BK 212HT is designed for high pressure/high temperature drip applications including steam main drip, turbine drain, etc. Excellent for superheated steam drip applications.

### Features and Benefits

- Forged alloy steel body with thick Titanium Body Shield to resist flashing damage.
- Titanium alloy valve and seat.
- Pressure assisted “fail open-only” design.
- Standard factory setting discharges hot condensate in a modulating fashion at approximately **18°F** (10°C) below saturation temperatures throughout its operating range.
- One internal bimetallic regulator for all applicable body pressure ranges.
- Staged “control valve” style nozzle reduces wiredrawing damage by reducing flashing. Totally unaffected by water hammer.
- Self draining – will not freeze when installed in gravity drainage position. Can be installed in any position.
- Automatically vents air and non-condensable gases and has a very high (>9:1) cold water capacity for rapid start-up.
- Operates with **zero steam loss** throughout its operating range saving steam and money during the life of the trap.
- Easy in-line inspection and maintenance – no need to remove the trap from the piping to clean or replace the internals.
- Valve and seat are a single, modular replacement part.
- Internal stainless steel strainer.
- Integral check valve design.
- Two (2) year guarantee.

### Materials

- Body and Cover – ASTM A182 F22
- Cover Bolts – 21 CrMoV 57 (DIN 1.7709)
- Bimetallic Regulator – Stainless Steels
- Stage Nozzle and Seat Ring – Titanium
- Other Internals – Stainless Steel



Pressure / Temperature Ratings					
Maximum Service Pressure	[psig]	4350	4350	2900	2350
	[barg]	300	300	200	162
Related Temperature	[°F]	100	1000	1049	1076
	[°C]	38	538	565	580
Maximum Differential Pressure		3625 psig (250 barg)			

Dimensions and Weights		End Connections								
		Flanged			Screwed Socket-Weld			Butt-Weld		
		1/2	3/4	1	1/2	3/4	1	1/2	3/4	1
Nominal Sizes	[inch] [mm]	1/2 15	3/4 20	1 25	1/2 15	3/4 20	1 25	1/2 15	3/4 20	1 25
Dimensions	L [inch] [mm]	17.7 450	18.9 480	18.9 480	13 330			13 330		
Approx. Weight	[lbs] [kg]	47.1 21.4	49.3 22.4	55.9 25.4	33.9 15.4			33.9 15.4		

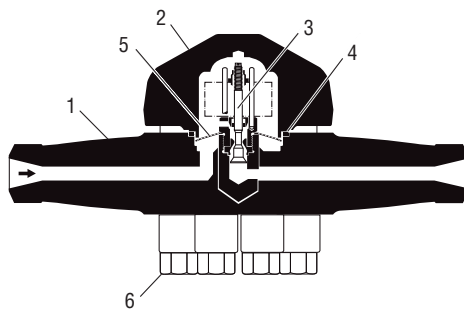
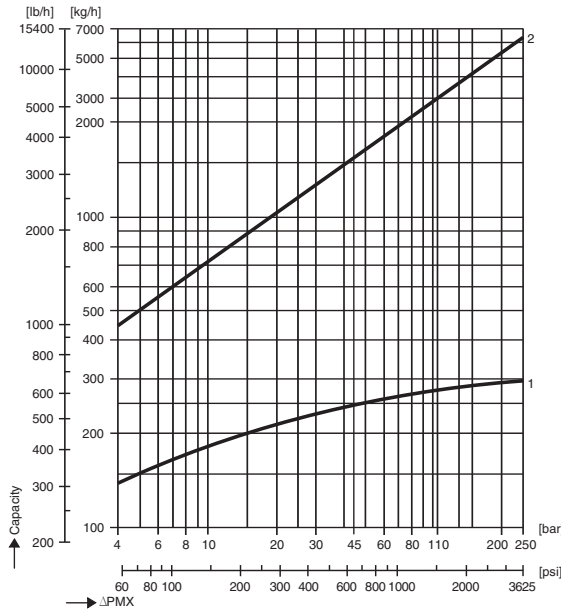
**3625**  
psi  
Maximum  $\Delta p$   
(250 bar)

**Gestra® Steam Trap •  
Thermostatic Steam Trap**

**BK 212HT**

**Class Rating:** PN 630

**Available Sizes:** ½", ¾" and 1"  
(DN 15, 20 and 25)



Standard Spare Parts		
Item Number	Description	BK 212HT
1	Body	-
2	Cover	089456
3	Regulator	371862
4	Cover Gasket	374009
5	Strainer	096345
6	Cover Bolts	013050
7	Cover Bolts Nuts	012073

**Capacity Charts**

The chart shows the maximum capacities for hot and cold condensate. The capacities are a function of differential pressure or the difference between inlet and outlet pressures for the trap.

Curve 1 shows the maximum capacity when discharging hot condensate that is **18°F (10°C)** below steam saturation temperature. For example, at a differential pressure of **2,000 psi** the maximum hot capacity is approximately **650 lb/hr.**

Curve 2 shows the maximum capacity when discharging cold condensate at a temperature of **68°F (20°C)**. For example, at a differential pressure of **2,000 psi** the maximum cold capacity is approximately **8,000 lb/hr.**

**Temperature Discharge Options**

Special factory adjustment of the regulator for increased undercooling is available for open discharge applications where sensible heat savings and flash steam suppression are desirable. Adjustment of the regulator for hotter discharge (less subcooling) is also available. Please contact your local Flowserve Gestra representative for more details.

**Body Pressure/Temperature Ratings**

The curve shows the maximum shell (body) pressure and temperature rating. Operating differential pressure is limited to **3,625 psi.**

**Material/Test Certificates**

All inspection requirements must be stated at time of order. Test certificates can be issued on request in accordance with EN 10204 – 2.2 and -3.1B. Heat codes from Body and cover are required.

**Available End Connections**

Flanges: ANSI 2500RF

Socket-weld: (Class 9000)

Butt-weld: (Sch 160, XXS)

**How to Order**

Specify trap, end connection size and type.

For Example: BK 212HT ½" Socketweld

# Gestra® Steam Trap • Thermostatic Steam Trap

## BK 212EX

**3625**  
psi  
Maximum Δp  
(250 bar)

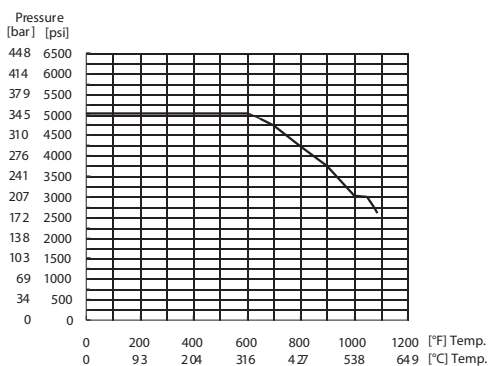
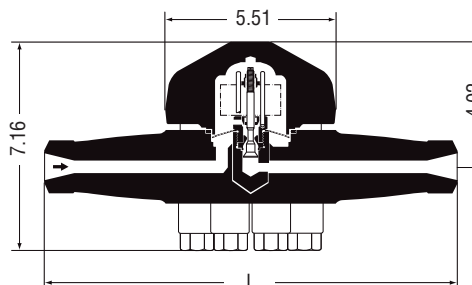
Available Sizes: 1/2", 3/4" and 1"  
(DN 15, 20 and 25)

### Application

The BK 212EX steam trap is used for low capacity drip leg applications such as superheated turbines, sootblowers and general distribution. The dissimilar stainless steel-shaped bimetallic plates and the specially staged titanium nozzle assure long-lasting service and zero steam loss operation even under superheat or water hammer conditions.

### Features and Benefits

- ASTM F91 Forged steel body.
  - Pressure assisted fail open design.
  - Modulating bimetallic regulator discharges hot condensate in a modulating fashion at approximately **18°F** (10°C) below saturation temperature throughout its operating range.
  - One internal regulator for all applicable pressure ranges. No adjustment required.
  - Operation is unaffected by water hammer or superheat.
  - Titanium Valve Nozzle and Body Shield.
  - Self draining – will not freeze when installed in gravity drainage position.
  - Automatically vents air and non-condensable gases and has a very high (>9:1) cold water capacity for rapid start-up.
  - Operates with **zero steam loss** throughout its operating range saving steam and money during the life of the trap.
  - Easy in-line inspection and maintenance – no need to remove the trap from the piping to replace the internals.
  - Can be installed in any position.
  - Internal stainless steel strainer.
  - Integral check valve design.
  - Two (2) year guarantee.
- ### Materials
- Body and Cover – A182 F91 (DIN 1.9403)
  - Cover Bolts – A453 Gr. 660 (DIN 1.4980)
  - Bimetallic Regulator – Stainless Steels
  - Stage Nozzle and Seat Ring – Titanium
  - Other Internals – Stainless Steel



Pressure / Temperature Ratings					
Maximum Service Pressure	[psig]	5040	4905	4230	2612
	[barg]	348	338	292	180
Related Temperature	[°F]	100	650	800	1090
	[°C]	38	343	427	588
Maximum Differential Pressure	3625 psig (250 barg)				

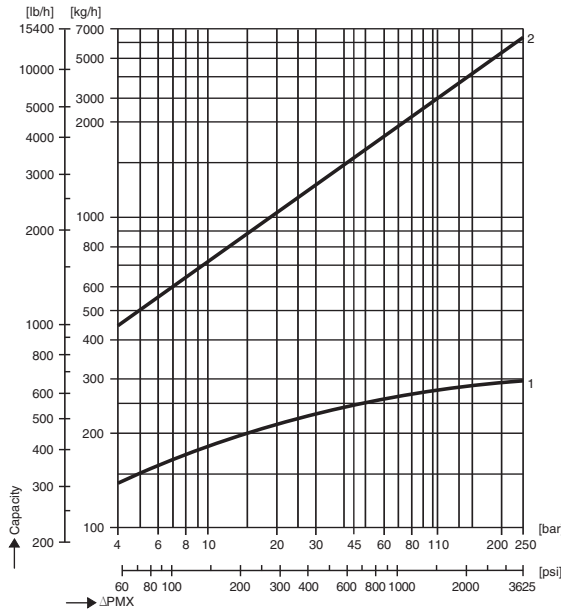
Dimensions and Weights		End Connections								
		Flanged			Screwed Socket-Weld			Butt-Weld		
Nominal Sizes	[inch] [mm]	1/2 15	3/4 20	1 25	1/2 15	3/4 20	1 25	1/2 15	3/4 20	1 25
Dimensions	L [inch]	17.7	18.9	18.9	13			13		
	[mm]	450	480	480	330			330		
Approx. Weight	[lbs]	47.1	49.3	55.9	33.9			33.9		
	[kg]	21.4	22.4	25.4	15.4			15.4		

**3625**  
psi  
Maximum  $\Delta p$   
(250 bar)

## Gestra® Steam Trap • Thermostatic Steam Trap

**BK 212EX**

**Available Sizes:** ½", ¾" and 1"  
(DN 15, 20 and 25)



### Capacity Charts

The charts show the maximum capacities for hot and cold condensate. The capacities are a function of differential pressure or the difference between inlet and outlet pressures for the trap.

Curve 1 shows the maximum capacity when discharging hot condensate that is **18°F (10°C)** below steam saturation temperature. For example, at a differential pressure of **2,000 psi** the maximum hot capacity is approximately **650 lb/hr.**

Curve 2 shows the maximum capacity when discharging cold condensate at a temperature of **68°F (20°C)**. For example, at a differential pressure of **2,000 psi**, the maximum cold capacity is approximately **8,000 lb/hr.**

### Temperature Discharge Options

Special factory adjustment of the regulator for increased undercooling is available for open discharge applications where sensible heat savings and flash steam suppression are desirable. For more details, contact your Gestra representative.

### Body Pressure/Temperature Ratings

The curve shows the maximum shell (body) pressure and temperature rating. Operating differential pressure is limited to **3,625 psi.**

### Material/Test Certificates

All inspection requirements must be stated with the order. Each BK 212 EX is supplied with a test certificate in accordance with EN 10204 – 3.1B. Special test and/or inspection certificates must be requested at time of order and cannot be issued after the equipment has been shipped from the factory.

### Available End Connections

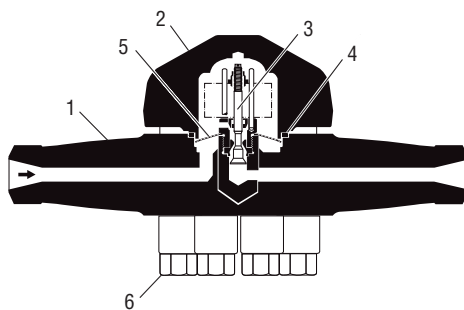
Socket-weld ends (Class 9000)

Butt-weld ends (Sch 160 or XXS)

### How to Order

Specify trap, end connection size and type.

For Example: BK 212EX 1" Socketweld



Standard Spare Parts		
Item Number	Description	BK 212EX
1	Body	-
2	Cover	374831
3	Regulator	370490
4	Cover Gasket	374009
5	Strainer	096345
6	Cover Bolts	Upon Request

# Gestra® Steam Trap • Thermostatic Steam Trap

**BK 15**

**320**  
psi  
Maximum Δp  
(22 bar)

**Class Rating:** ANSI 300

**Available Sizes:** 1½" and 2"  
(DN 40 and 50)

### Application

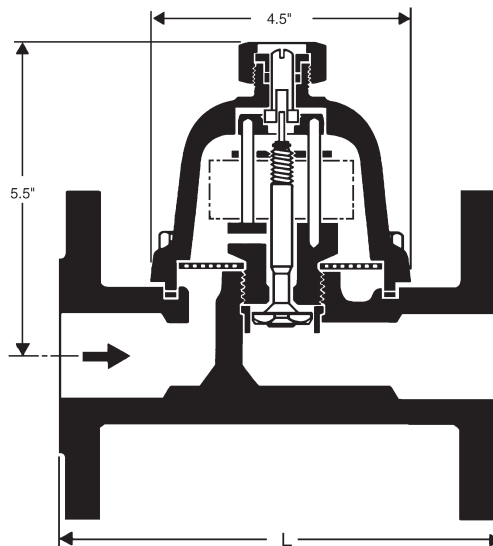
The BK 15 steam trap is used for medium capacity applications such as heat exchangers, large air preheaters, tank heaters, etc. The stainless steel bimetallic plates and the staged nozzle assure long-lasting service and zero steam loss operation even under superheat conditions and water-hammer conditions.

### Features and Benefits

- Forged carbon steel body.
- Pressure assisted fail open design.
- Modulating bimetallic regulator with fatigue-free stainless steel plates. No adjustment required.
- In-line adjustment available for characterization to process conditions and effects of back pressure.
- Discharges hot condensate at approximately **18°F** (10°C) below saturation temperature throughout its operating range. One internal regulator for all pressure ranges.
- Operation is unaffected by water hammer or superheat.
- Self draining – will not freeze when installed in gravity drainage position.
- Automatically vents non-condensables and has a high (>3:1) cold water capacity for rapid start-up.
- Operates with zero steam loss throughout its operating range saving steam and money during the life of the trap.
- Easy in-line inspection and maintenance – no need to remove the trap from the piping to replace the internals.
- Can be installed in any position.
- Internal stainless steel strainer.
- Integral check valve design.
- Two (2) year guarantee.

### Materials

- Body and Cover – ASTM A105 (DIN 1.0460)
- Cover Bolts – ASTM A193B7 (DIN 1.7258)
- Bimetallic Regulator – Stainless Steels
- Other Internals – Stainless Steel



Pressure / Temperature Ratings				
Maximum Service Pressure	[psig]	464	319	210
	[barg]	32	22	14.5
Related Temperature	[°F]	482	725	842
	[°C]	250	385	450
Maximum Differential Pressure		320 psig (22 barg)		

Dimensions and Weights	End Connections										
	Flanged to DIN		Flanged to ANSI 150		Flanged to ANSI 300		Socket weld		Butt-weld		
Nominal Size	[inch]	1 1/2	2	1 1/2	2	1 1/2	2	1 1/2	2	1 1/2	2
	[mm]	40	50	40	50	40	50	40	50	40	50
Face to Face	L [inch]	9.06	9.06	9.06	9.06	9.06	5.12	8.27	9.84	9.84	
	[mm]	230	230	230	230	230	130	210	250	250	
D	[inch]	5.90	6.50	—	—	5.90	6.50	—	—	—	—
	[mm]	150	165	—	—	150	165	—	—	—	—
b	[inch]	0.71	0.79	—	—	0.81	0.88	—	—	—	—
	[mm]	18	20	—	—	20.5	22.4	—	—	—	—
k	[inch]	4.33	4.92	—	—	4.50	5.00	—	—	—	—
	[mm]	110	125	—	—	114.3	127	—	—	—	—
g	[inch]	3.46	2.45	—	—	2.88	3.62	—	—	—	—
	[mm]	88	102	—	—	73.2	91.9	—	—	—	—
l	[inch]	0.71	0.71	—	—	.88	.75	—	—	—	—
	[mm]	18	18	—	—	22.4	19	—	—	—	—
Number of Bolts		4	4	—	—	4	8	—	—	—	—
Approx. Weight	[lbs]	24.3	27.6	—	—	24.3	27.6	13.9	17	15	16.5
	[kgs]	11	12.5	—	—	11	12.5	6.3	7.7	6.8	7.5

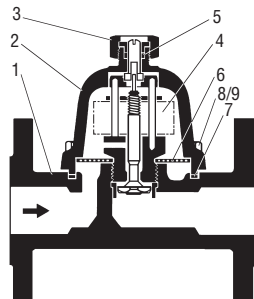
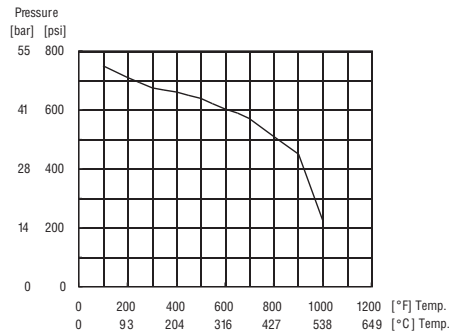
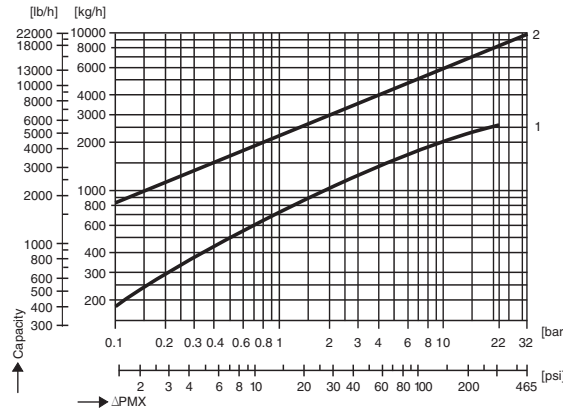
**320**  
psi  
Maximum  $\Delta p$   
(22 bar)

## Gestra® Steam Trap • Thermostatic Steam Trap

**BK 15**

**Class Rating:** ANSI 300

**Available Sizes:** 1½" and 2"  
(DN 40 and 50)



Standard Spare Parts		
Item Number	Description	BK 15
1	Body	
2	Cover	096887
3	Cover Plug	013642
4	Regulator	098847
5	Cover Plug Gasket	371908
6	Strainer	096891
7	Cover Gasket	087095
8	Cover	
	Bolts	014405
	Nuts	013124

### Capacity Charts

The charts show the maximum capacities for hot and cold condensate. The capacities are a function of differential pressure or the difference between inlet and outlet pressures for the trap.

Curve 1 shows the maximum capacity when discharging hot condensate that is **18°F (10°C)** below steam saturation temperature. For example, at a differential pressure of **100 psi (7 bar)**, the maximum hot capacity is approximately **3,500 lb/hr.**

Curve 2 shows the maximum capacity when discharging cold condensate at a temperature of **68°F (20°C)**. For example, at a differential pressure of **100 psi**, the maximum cold capacity is approximately **11,000 lb/hr.**

### Temperature Discharge Options

Special factory adjustment of the regulator for increased undercooling is available for open discharge applications where sensible heat savings and flash steam suppression are desirable. For more details, contact your Gestra representative.

### Body Pressure/Temperature Ratings

The curve shows the maximum shell (body) pressure and temperature rating. Operating differential pressure is limited to **320 psi.**

### Material/Test Certificates

The following test certificates can be issued on request at extra cost in accordance with EN 10204 – 2.2 and -3.1B. All inspection requirements must be stated with the order. Heat Codes from body and cover are required.

### Available End Connections

Flanges: ANSI 150 or 300 (DIN PN 40)

Screwed sockets: BSP or NPT (API)

Socket-weld ends

Butt-weld ends

### How to Order

Specify trap, end connection size and type.

For Example: BK 15 1½" NPT



# Gestra® Steam Trap • Thermostatic Steam Trap

**BK 27**

650

psi  
Maximum Δp  
(45 bar)

**Class Rating:** PN 63

**Available Sizes:** 1½" and 2"  
(DN 40 and 50)

**Application**

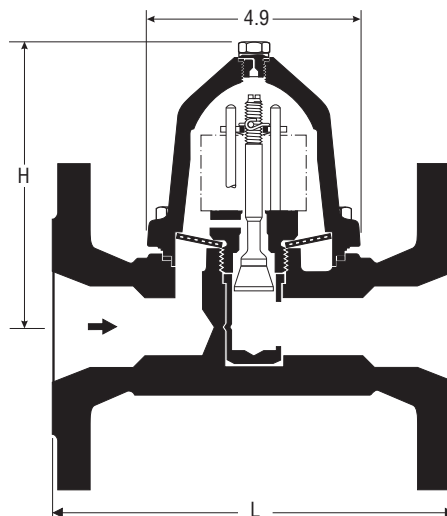
The BK 27 steam trap is used for higher pressure medium-capacity applications such as heat exchangers, large air preheaters, tank heaters, etc. The stainless steel bimetallic plates and the staged nozzle assure long lasting service and zero steam loss operation even under superheat or waterhammer conditions.

**Features and Benefits**

- Forged carbon steel body.
- Pressure assisted fail open design.
- Modulating bimetallic regulator with fatigue free stainless steel plates. No adjustment required.
- In-line adjustment available for characterization to process conditions and effects of back pressure.
- Discharges hot condensate at approximately **18°F (10°C)** below saturation temperature throughout its operating range. One internal regulator for all pressure ranges.
- Unaffected by water hammer – Solid stainless steel internals.
- Self draining – will not freeze when installed in gravity drainage position.
- Automatically vents non-condensables and has a high (>8:1) cold water capacity for rapid start-up.
- Operates with **zero steam loss** throughout its operating range saving steam and money during the life of the trap.
- Easy in-line inspection and maintenance – no need to remove the trap from the piping to replace the internals.
- Can be installed in any position.
- Integral stainless steel strainer.
- Internal check valve design.
- Two (2) year guarantee.

**Materials**

- Body and Cover – ASTM A182 F1 (DIN 1.5415)
- Cover Bolts – ASTM A193 B7 (DIN 1.7258)
- Bimetallic Regulator – Stainless Steels
- Other Internals – Stainless Steel



Pressure / Temperature Ratings				
Maximum Service Pressure	[psig]	<b>812</b>	<b>682</b>	<b>653</b>
	[barg]	56	47	45
Related Temperature	[°F]	<b>572</b>	<b>752</b>	<b>842</b>
	[°C]	300	400	450
Maximum Differential Pressure	<b>650 psig (45 barg)</b>			

Dimensions and Weights		End Connections					
		Flanged		Socket-Weld		Butt-Weld	
Nominal Sizes	[inch]	<b>1 1/2</b>	<b>2</b>	<b>1 1/2</b>	<b>2</b>	<b>1 1/2</b>	<b>2</b>
	[mm]	40	50	40	50	40	50
Dimensions	L [inch]	<b>9.1</b>	<b>11.8</b>	<b>7.1</b>	<b>7.1</b>	<b>7.1</b>	<b>7.1</b>
	[mm]	230	300	180	180	180	180
	H [inch]	<b>6.2</b>	<b>6.2</b>	<b>6.2</b>	<b>6.2</b>	<b>6.2</b>	<b>6.2</b>
	[mm]	157	157	157	157	157	157
Approx. Weight	[lbs]	<b>44</b>	<b>44</b>	<b>19.8</b>	<b>19.8</b>	<b>19.8</b>	<b>19.8</b>
	[kg]	20	20	9	9	9	9

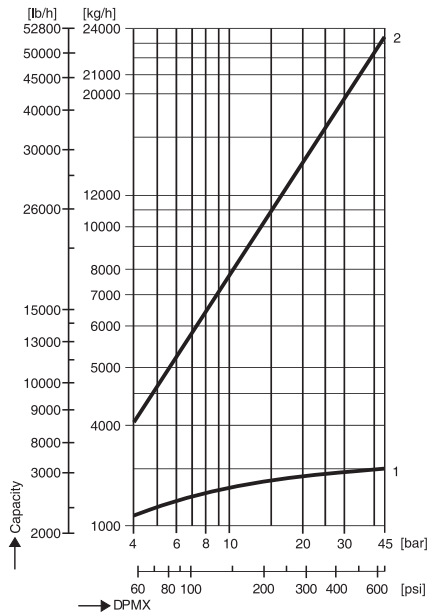
**650**  
psi  
Maximum  $\Delta p$   
(45 bar)

**Gestra® Steam Trap •  
Thermostatic Steam Trap**

**BK 27**

**Class Rating:** PN 63

**Available Sizes:** 1½" and 2"  
(DN 40 and 50)



**Capacity Charts**

The charts show the maximum capacities for hot and cold condensate. The capacities are a function of differential pressure or the difference between inlet and outlet pressures for the trap.

Curve 1 shows the maximum capacity when discharging hot condensate that is **18°F (10°C)** below steam saturation temperature. For example, at a differential pressure of **400 psi** the maximum hot capacity is approximately **3,000 lb/hr.**

Curve 2 shows the maximum capacity when discharging cold condensate at a temperature of **68°F (20°C)**. For example, at a differential pressure of **400 psi** the maximum cold capacity is approximately **40,000 lb/hr.**

**Temperature Discharge Options**

Special factory adjustment of the regulator for increased undercooling is available for open discharge applications where sensible heat savings and flash steam suppression are desirable. For more details, contact your Gestra representative.

**Body Pressure/Temperature Ratings**

The chart shows the maximum shell (body) pressure and temperature rating. Operating differential pressure is limited to **650 psi.**

**Material/Test Certificates**

The following test certificates can be issued on request in accordance with EN 10204 – 2.2 and -3.1B. All inspection requirements have to be stated with the order. Test and/or Inspection certificates must be requested at time of order and cannot be issued after the equipment has been shipped from the factory.

**Available End Connections**

Flanges: ANSI 300RF, 600RF, DIN

NPT

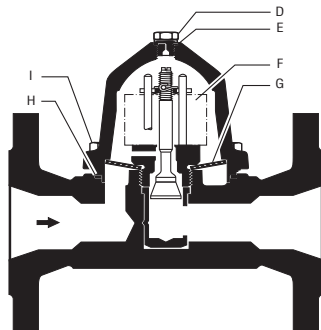
SW, BW

**How to Order**

Specify trap, end connection size and type.

For Example: BK 27 1½" NPT

If ANSI flanged ends are required, specify either ANSI 300 RF or ANSI 600 RF.



Standard Spare Parts		
Item Number	Description	BK 27
D	Cover Plug	096178
E	Cover Plug Gasket	000992
F	Regulator	098854
G	Strainer	097018
H	Cover Gasket	086536
I	Cover Bolts	014231

## Ball Float Traps – UNA

### Pressure ratings up to PN 160

#### For condensate discharge without banking-up even with load and pressure fluctuations.

Ball float traps are also suitable for the discharge of cold condensates, distillates and condensate derived from chemical products. They operate without any banking-up, even with considerable load and pressure fluctuations and at any back pressure. Compared with other trap types, they are the least affected by dirt.

The traps are supplied with either “Duplex” control (thermostatic bellows for automatic air-venting) or with “Simplex” control (without bellows) and hand vent valve. The control unit is easily accessible after removing the trap cover and can be changed as a complete unit without removing the trap from the line.

The rolling ball valve produces very little friction and can be operated with a minimum of force. This results in small, light traps but with large capacities.

**UNA 14 PN 16, UNA 16 PN 25** compact trap for small condensate flowrates. Design “h” for horizontal and design “v” for vertical pipework. A conversion of “h” design to “v” design or vice versa is possible by repositioning body and control unit to suit the pipework layout.

**UNA 23 PN 16, UNA 25 PN 40, UNA 26 PN 40** For large condensate flowrates. Design “h” for horizontal and design “v” for vertical pipework.

For particularly aggressive fluids or special hygienic requirements, the UNA 26 and UNA 16 are also available made completely of stainless steel.

**UNA 27h PN 63** For differential pressures up to 652 psi (45 bar). Installation in horizontal pipework.

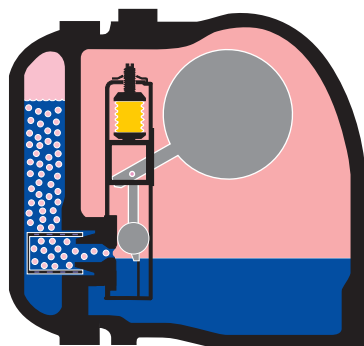
**UNA 39 PN 160** Float trap controlled by the float. Only for smaller flowrates.

**UNA 39, maximum orifice 140, PN 160** The trap operates with pilot control (without auxiliary power). It therefore discharges large amounts of condensate at high pressures without requiring a large trap body.

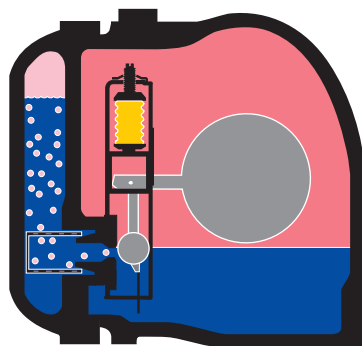


### Operation

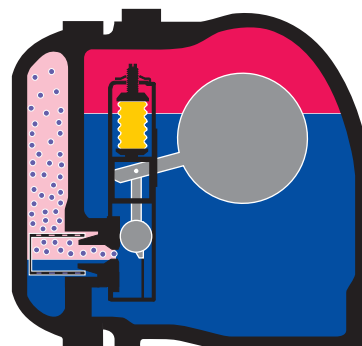
Air-venting when system is cold (start-up condition).

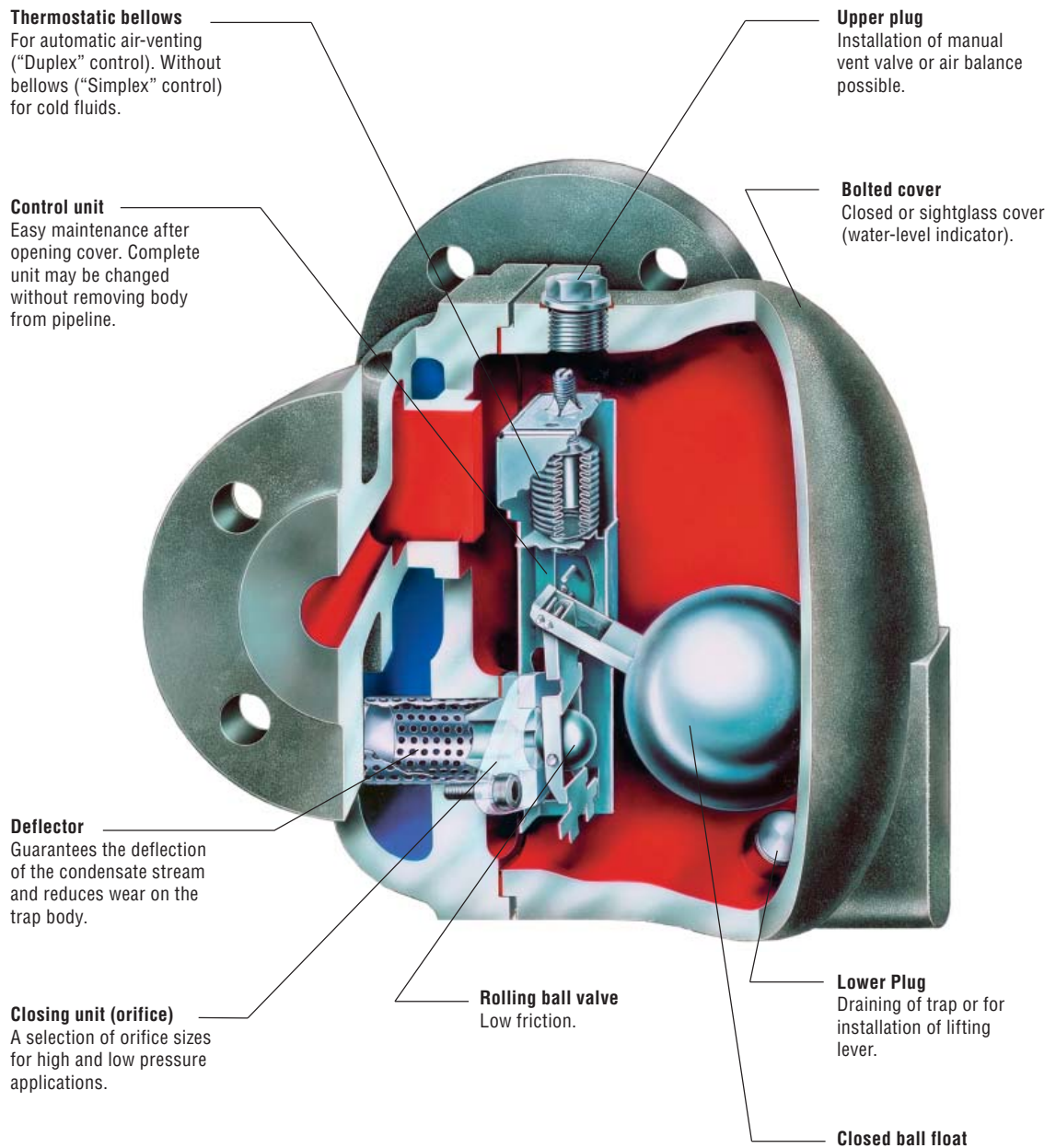


Air-venting during operation (temperature lower than standard steam temperature).



Discharge of boiling hot condensate (temperature equals saturation temperature).





# Gestra® Steam Trap • Float and Throstatic Steam Trap

## UNA 14 and UNA 16

305

psi  
Maximum Δp  
(21 bar)

**Class Rating:** UNA 14 - PN 16  
UNA 16 - PN 25

**Available Sizes:** 1/2", 3/4" and 1"  
(DN 15, 20 and 25)

### Application

The UNA 14 and UNA 16 are designed for low to medium capacity applications such as (inside) drips, small unit heaters, heat exchangers, etc., where maximum air handling, hot discharge and modulating operation are required. Very useful for low differential applications such as HVAC.

### Trap Types

UNA 14: Cast Steel, 185 Maximum Δp

UNA 16: Cast Steel, 305 Maximum Δp

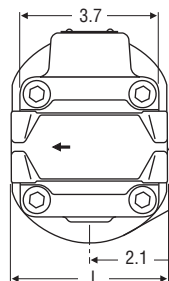
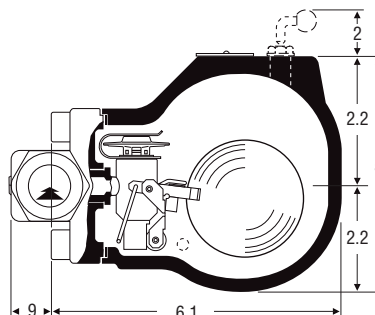
UNA 16SST: All SST construction, 305 Maximum Δp.

### Features and Benefits

- Flowserve Gestra modulating membrane regulator for fast bypass release of cold water and air providing for quick startups.
- Removable bolted cover for in-line inspection and maintenance.
- Steam trap comes in either horizontal (h) or vertical (v) orientation.
- Easily field convertible between horizontal (h) and vertical (v) orientation or vice versa for reduction of inventory.
- Operation is unaffected by back pressure.
- Rolling SST ball valve mechanism ensures smooth operation with no sticking and minimum wear.
- Optional Hand Vent Valve for manual pressure release prior to servicing.
- Two (2) year guarantee.

### Materials

- UNA 14 – Body - ASTM A105 (DIN 1.0460)  
Cover - A536 60-40-48 (EN-JS-1049)
- UNA 16 – Body - ASTM A105 (DIN 1.0460)  
Cover - ASTM A216 WCB (DIN 1.0619)
- UNA 16A – Body - ASTM A182 F316L (DIN 1.4404)  
Cover - ASTM A351 CF 8 (DIN 1.4308)
- Regulator – Hastelloy® and Stainless Steel
- All Other Internals – Stainless Steel



Pressure / Temperature Ratings

Body Style	UNA 14			
Maximum Service Pressure	[psig] 368	285	262	221
	[barg] 25	19.4	17.8	15
Related Temperature	[°F] 68	392	482	662
	[°C] 20	200	250	350
Maximum Differential Pressure	185 psi (13 bar)			

Body Style	UNA 16				UNA 16A			
Maximum Service Pressure	[psig] 254	203	150	96	284	250	206	150
	[barg] 17.3	13.8	10.2	6.5	19.3	17	14	10.2
Related Temperature	[°F] 68	392	572	752	68	212	392	572
	[°C] 20	200	300	400	20	100	200	300
Maximum Differential Pressure	320 psi (22 bar)				320 psi (22 bar)			

Dimensions and Weights		Nominal Sizes		
		1/2	3/4	1
End Connections	[inch]	15	20	25
	[mm]	150	150	160
Flanged L	[inch]	7.9	7.9	7.9
	[mm]	200	200	200
Butt-Weld L	[inch]	3.7	3.7	3.7
	[mm]	95	95	95
Socketweld L	[inch]	13	14	15
Screwed	[mm]	6	6.5	7
Approx. Weight	Flanged [lbs]	10	10	3
	[kg]	4.5	4.5	1.5
	S.W., B.W. [lbs]	10	10	3
	[kg]	4.5	4.5	1.5

**305**

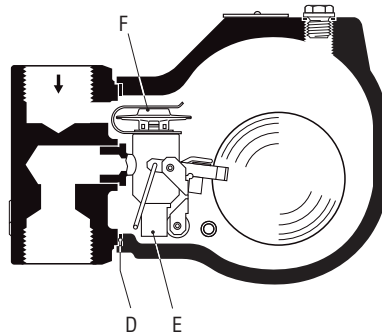
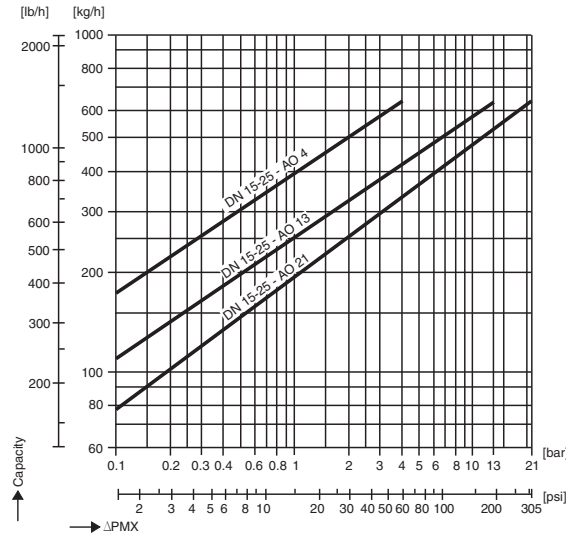
psi  
Maximum  $\Delta p$   
(21 bar)

**Gestra® Steam Trap • Float  
and Thermostatic Steam Trap**

**UNA 14 and UNA 16**

**Class Rating:** UNA 14 - PN 16  
UNA 16 - PN 25

**Available Sizes:** ½", ¾" and 1"  
(DN 15, 20 and 25)



**Capacity Charts**

The charts show the maximum capacities of hot water based on the orifice of the steam traps. The capacities are a function of differential pressure, or the difference between inlet and outlet pressures for the trap.

The cold water capacities are between 1.1 and 1.7 times the hot capacities, depending on the differential pressure.

**Orifice Number**

The orifice number listed on the capacity line refers to the maximum differential pressure (in bar) for which a trap with that orifice may be used. Each orifice has a different diameter and will provide a different capacity.

Select the curve appropriate for the application without exceeding the maximum differential pressure.

At a **200 psi** differential, the UNA 16 must be used only with orifice 21. Orifices 4 or 13 cannot be used at this differential pressure.

**Body Pressure/Temperature Rating**

The chart shows the maximum shell (body) pressure and temperature rating. Operating differential pressure is limited to **185 psi** for the UNA 14 and **305 psi** for the UNA 16.

**Material/Test Certificates**

Test certificates can be issued on request in accordance with EN 10204 – 2.2 and -3.1B. All inspection requirements must be stated with the order. Heat codes from body and cover are required.

**Available End Connections**

Flanged: ANSI 150RF, 300RF

UNA 16: ANSI 300RF only

NPT

BW, SW

**How to Order**

Specify trap, end connection and size, orientation (h or v) and orifice.

For Example: UNA 16Dh A013 1" NPT

If ANSI flanged ends are required, please specify either ANSI 150 RF or ANSI 300 RF.

**Standard Spare Parts**

Item Number	Description	UNA 14	UNA 16
Da	Simplex Control Unit		
	R Orifice 4	560413	560413
	R Orifice 13	560412	560412
	R Orifice 21	—	560411
Db	Simplex Control Unit		
	Orifice 4	560416	560416
	Orifice 13	560415	560415
	Orifice 21	—	560414
Dc	Duplex Control Unit		
	Orifice 4	560410	560410
	Orifice 13	560409	560409
	Orifice 21	—	560408
F	Thermostatic Capsule (5N2)	376175	376175
G	Cover Gasket	522752	522754

# Gestra® Steam Trap • Float and Throstatic Steam Trap

## UNA 26H

**465**  
psi  
Maximum Δp  
(32 bar)

**Class Rating:** PN 40

**Available Sizes:** 1/2", 3/4", 1", 1 1/2" and 2"  
(DN 15, 20, 25, 40 and 50)

### Application

The UNA 26 is designed for medium to high capacity applications where maximum air handling, hot discharge, modulating operation are required. These applications include reboilers, heat exchangers, etc., SST thermostatic element used for automatic deaeration during startup and upset opens annular orifice for maximum air venting and high cold water capacity for rapid startup.

### Features and Benefits

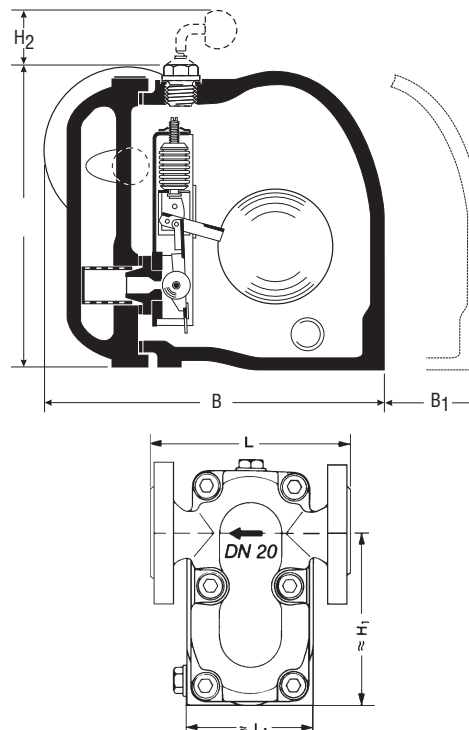
- Bolted cover for in-line inspection and maintenance.
- Operation is unaffected by back pressure.
- Duplex design with single integrated valve and seat automatically vents non-condensable gases at higher capacity than competitive F&T's using small orifice bypasses.
- Rolling ball valve mechanism ensures smooth operation with no sticking and minimum wear.
- Two (2) year guarantee.

### Options

- Hand Vent Lifting Lever for manual purge.
- Vent valve for manual override of air venting or balancing line connection.

### Materials

- Body and Cover – ASTM-A216 WCB (DIN 1.0619)
- Bolts – ASTM A193 B16 (DIN 1.7709)
- Nuts – ASTM A193 B16 (DIN 1.7258)
- Other Internals – Stainless Steel



Dimensions and Weights		End Connections				
Nominal Sizes	[inch] [mm]	1/2 15	3/4 20	1 25	1 1/2 40	2 50
Dimensions	B [inch] [mm]	7.4 187	7.6 192	7.8 197	11.6 294	11.9 302
	B1 [inch] [mm]	5 130	5 130	5 130	8 200	8 200
	H [inch] [mm]	7 184	7 184	7 184	13 318	13 318
	H1 [inch] [mm]	5 126	5 126	5 126	9 219	9 219
	H2 [inch] [mm]	1.5 38	1.5 38	1.5 38	1.5 38	1.5 38
Flanged	L [inch] [mm]	8.3 210	8.3 210	9.1 230	12.6 320	12.6 320
Butt-weld	L [inch] [mm]	7.9 200	7.9 200	7.9 200	9.1 230	9.1 230
Socket-weld	L [inch] [mm]	7.9 200	7.9 200	7.9 200	9.1 230	9.1 230
Screwed	L [inch] [mm]	7.9 200	7.9 200	7.9 200	10 255	10 255
	L1 [inch] [mm]	3.7 94	3.7 94	3.7 94	6.1 154	6.1 154
Approx. Weight	[lbs] [kg]	21 9.5	22 10	23 10.5	66 30	68 31

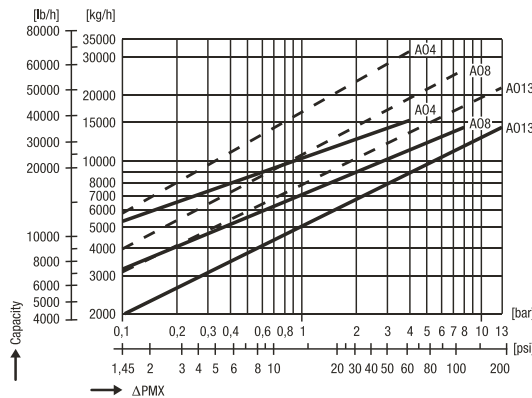
**465**  
psi  
Maximum  $\Delta p$   
(32 bar)

## Gestra® Steam Trap • Float and Throstatic Steam Trap

**UNA 26H**

**Class Rating:** PN 40

**Available Sizes:** 1/2", 3/4", 1", 1 1/2" and 2"  
(DN 15, 20, 25, 40 and 50)



### Capacity Charts

The charts show the maximum hot water capacities for UNA 26 steam traps. The capacities are a function of differential pressure or the difference between inlet and outlet pressures for the trap. The cold water (start-up) capacity is between 1.1 and 1.7 times the hot capacity dependent on the differential pressure. For cold water or other fluids, consult Flowserve Gestra.

### Orifice Number

The orifice number listed on the capacity line refers to the maximum differential pressure (in bar) for which the UNA 26 with that orifice may be used. Each orifice has a different diameter and will provide a different capacity. Select the line appropriate for the application without exceeding the maximum differential pressure.

**NOTE:** At a 200 psi differential, the UNA 26 must be used only with orifice 22 or orifice 32. Orifices 2, 4, 8 and 13 cannot be used at this differential pressure.

### Body Pressure/Temperature Rating

The chart shows the maximum shell (body) pressure and temperature rating. Operating differential pressure is limited to 465 psi.

### Available End Connections

Flanged: ANSI 150RF or 300RF

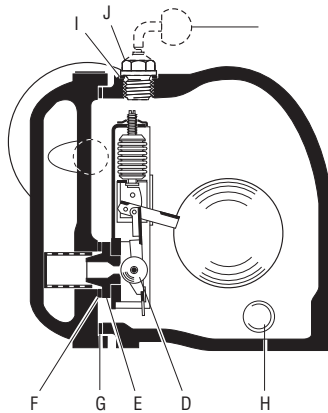
Socket-weld, Butt weld

NPT

### How to Order

Specify trap, end connection size and type.

For Example: UNA 26H Duplex A022 1" NPT



Standard Spare Parts		
Item Number	Description	UNA 26
D	Control Unit	Varies with orifice
E	Seat	Varies with orifice
F	Seat Gasket	1/2" - 1" 522388
		1 1/2" - 2" 522389
G	Cover Gasket	1/2" - 1" 522243
		1 1/2" - 2" 522244
H	Optional Float Lifting Lever	1/2" - 1" 560061
		1 1/2" - 2" 560062
I	Plug Gasket	013849
J	Plug (3/8" BSP) Optional Hand Vent Valve	012537
		560058



# Gestra® Steam Trap • Float and Throstatic Steam Trap

## UNA 26H MAX

**465**  
psi  
Maximum Δp  
(32 bar)

**Class Rating:** PN 40

**Available Sizes:** 1 1/2" and 2"  
(DN 40 and 50)

### Application

The UNA 26H MAX is designed for medium to high capacity applications where maximum air handling, hot discharge, modulating operation and a fail open design are required. These applications include reboilers, heat exchangers, etc., SST thermostatic element used for automatic deaeration during startup and upset opens annular orifice for maximum air venting and high cold water capacity for rapid startup.

### Features and Benefits

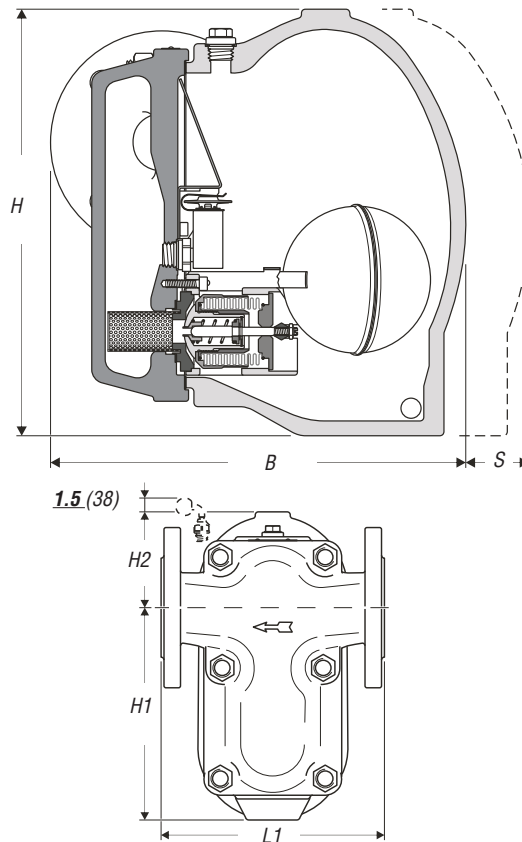
- Bolted cover for in-line inspection and maintenance.
- Operation is unaffected by back pressure.
- Duplex design automatically vents non-condensable gases at higher capacity than competitive F&T's using small orifice bypasses.
- Rolling ball valve mechanism ensures smooth operation with no sticking and minimum wear.
- Internal SST Strainer.
- Two (2) year guarantee.

### Options

- Hand Vent Lifting Lever for manual purge.
- Vent valve for manual override of air venting or balancing line connection.

### Materials

- Body and Cover – ASTM-A216 WCB (DIN 1.0619)
- Bolts – ASTM A193 B16 (DIN 1.7709)
- Nuts – ASTM A193 B16 (DIN 1.7258)
- Other Internals – Stainless Steel



Dimensions and Weights		End Connections	
Nominal Sizes	[inch] [mm]	1 1/2 40	2 50
Dimensions	B [inch] [mm]	11.9 301	12.1 308
	H [inch] [mm]	13 318	13 318
	H1 [inch] [mm]	9 219	9 219
	H2 [inch] [mm]	3.9 99	3.9 99
Flanged	L [inch] [mm]	12.6 320	12.6 320
	Butt-weld	L [inch] [mm]	9.1 230
Socket-weld		L [inch] [mm]	9.1 230
	Screwed	L [inch] [mm]	10 255
L1		[inch] [mm]	6.1 154
	Approx. Weight	[lbs] [kg]	58 26.4

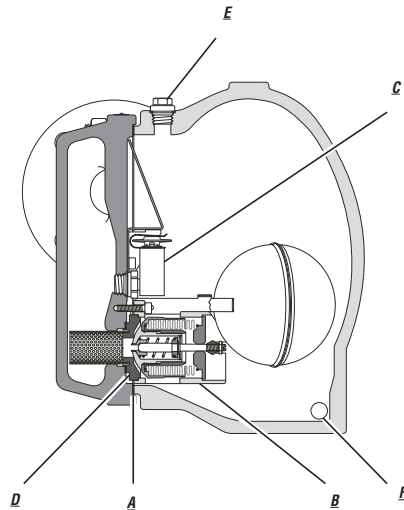
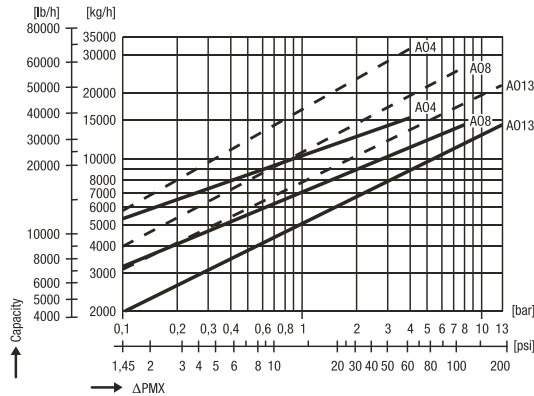
**465**  
psi  
Maximum  $\Delta p$   
(32 bar)

## Gestra® Steam Trap • Float and Throstatic Steam Trap

## UNA 26H MAX

**Class Rating:** PN 40

**Available Sizes:** 1 1/2" and 2"  
(DN 40 and 50)



### Capacity Charts

The charts show the maximum hot water capacities for UNA 26H MAX steam traps. The capacities are a function of differential pressure or the difference between inlet and outlet pressures for the trap. The hotwater capacities are indicated by the solid lines. The cold water (start-up) capacity is indicated by the dashed lines.

### Orifice Number

The orifice number listed on the capacity line refers to the maximum differential pressure (in bar) for which the UNA 26H MAX with that orifice may be used. Each orifice has a different diameter and will provide a different capacity. Select the line appropriate for the application without exceeding the maximum differential pressure.

**NOTE:** At a **200 psi** differential, the UNA 26 must be used only with orifice 22 or orifice 32. Orifices 2, 4, 8 and 13 cannot be used at this differential pressure.

### Body Pressure/Temperature Rating

The chart shows the maximum shell (body) pressure and temperature rating. Operating differential pressure is limited to **465 psi**.

### Available End Connections

Flanged: ANSI 150RF or 300RF

Socket-weld, Butt weld

NPT

### How to Order

Specify trap, end connection size and type.

For Example: UNA 26H Duplex A022 1" NPT

Standard Spare Parts		
Item Number	Description	1-1/2" - 2"
A	Body Gasket	560492
B	Duplex Control Unit with body gasket	Orifice 4 MAX 560575
		Orifice 8 MAX 560576
		Orifice 13 MAX 560577
		Orifice 22 MAX 560578
		Orifice 32 MAX 560579
		Simplex Control Unit with body gasket
	Orifice 8 MAX 560581	
	Orifice 13 MAX 560582	
	Orifice 22 MAX 560583	
	Orifice 32 MAX 560584	
C	Air Venting Unit, Compete, for Duplex Max Control Unit	560548
D	Seat and Seat Gasket	Orifice 4 MAX 560570
		Orifice 8 MAX 560571
		Orifice 13 MAX 560572
		Orifice 22 MAX 560573
		Orifice 32 MAX 560574
E	Hand vent valve with gasket (Optional)	560058
F	Float lifting lever with gasket (Optional)	On Request

# Gestra® Steam Trap • Float and Throstatic Steam Trap

UNA 27H

**650**  
psi  
Maximum Δp  
(45 bar)

**Class Rating:** PN 63

**Available Sizes:** 1", 1½" and 2"  
(DN 25, 40 and 50)

**Application**

The UNA 27h steam trap is used for high pressure process applications with medium- to high-capacity condensate loads such as reboilers, heat exchangers, steam separators, etc., modulating hot discharge is required. SST thermo-static element used for automatic deaeration during startup and upset opens annular orifice for maximum air venting and high cold water capacity for rapid startup.

**Features and Benefits**

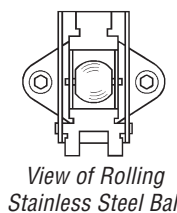
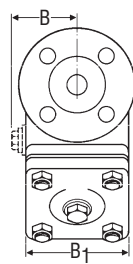
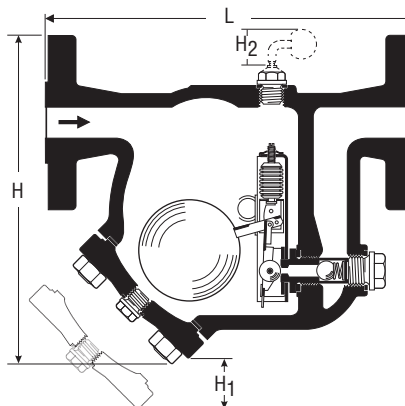
- In-line inspection and maintenance utilizing bolted cover.
- Horizontal Mounting (h) only.
- Operation is unaffected by back pressure.
- Duplex design with single integrated valve and seat automatically vents non-condensable gases at higher capacity than competitive F&T's using small orifice bypasses.
- Rolling ball valve mechanism ensures smooth operation with no sticking and minimum wear.
- Two (2) year guarantee.

**Options**

- Hand Vent Lifting Lever for manual purge.
- Vent valve for manual override of air venting or balancing line connection.

**Materials**

- Body and Cover – ASTM A217 WC1 (DIN 1.5419)
- Cover Screws – ASTM A193 B16 (DIN 1.7709)
- Nuts – ASTM A193 B7 (DIN 1.7258)
- Other Internals – Stainless Steel



View of Rolling Stainless Steel Ball

Dimensions and Weights	End Connections			
		1	1 1/2	2
Nominal Sizes	[inch]	1	1 1/2	2
	[mm]	25	40	50
Dimensions	B [inch]	3.1	4.4	4.4
	[mm]	80	111	111
	B1 [inch]	5	9	9
	[mm]	126	225	225
	H [inch]	11	17	17
	[mm]	278	420	420
H1 [inch]	2	2	2	
	[mm]	50	50	50
H2 [inch]	1.6	1.6	1.6	
	[mm]	40	40	40
Flanged ANSI 300	L [inch]	11.3	15.9	16.1
	[mm]	287	405	408
Flanged ANSI 400/600	L [inch]	11.8	16.6	16.8
	[mm]	300	421	427
Butt-weld	L [inch]	11.8	16.5	16.5
	[mm]	300	420	420
Approx. Weight	[lbs]	44	119	121
	[kg]	20	54	55

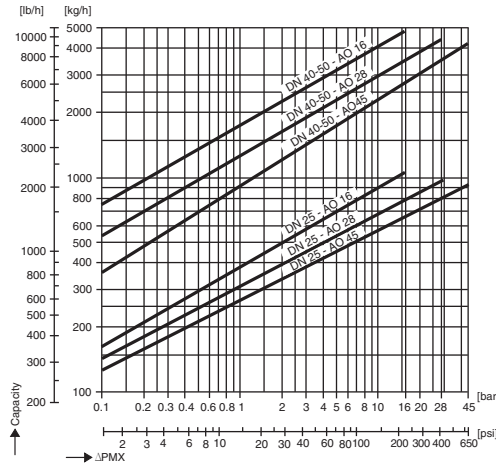
**650**  
psi  
Maximum  $\Delta p$   
(45 bar)

## Gestra® Steam Trap • Float and Throstatic Steam Trap

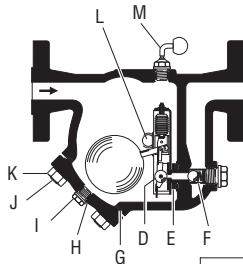
**UNA 27H**

**Class Rating:** PN 63

**Available Sizes:** 1", 1½" and 2"  
(DN 25, 40 and 50)



Pressure / Temperature Ratings					
Maximum Service Pressure	[psig]	915	810	680	650
	[barg]	63	56	47	45
Related Temperature	[°F]	482	572	752	842
	[°C]	250	300	400	450
Maximum Differential Pressure		650 psig (45 barg)			



Standard Spare Parts		
Item Number	Description	UNA 27h
D	Control Unit	Varies with orifice
E	Seat	Varies with orifice
F	Check Valve	1" 560406
		1 1/2" - 2" 560407
G	Cover Gasket	1" 522247
		1 1/2" - 2" 522248
H	Drain Plug Gasket	012579
I	Optional Drain Plug	012576
J	Cover Bolts	1" 012578
		1 1/2" - 2" 012562
K	Nuts	010168
L	Optional Float Lifting Lever	1" 560063
		1 1/2" - 2" 560064
M	Optional Hand Vent Valve & Gasket	560059

### Capacity Charts

The charts show the maximum capacities for hot condensate. The capacities are a function of differential pressure or the difference between inlet and outlet pressures for the trap. For example, at a 200 psi differential, the 1" UNA 27h with an orifice 28 has a capacity of about 1,700 lb/hr. The cold water (start-up) capacity is between 1.1 and 1.6 times the hot capacity, dependent on the differential pressure.

### Orifice Number

The orifice number listed on the capacity line refers to the maximum differential pressure (in bar) for which the UNA 27h with that orifice may be used. Each orifice has a different diameter and will provide a different capacity. Select the line which is appropriate for the application without exceeding the maximum differential pressure.

**NOTE:** At a 200 psi differential, the UNA 26 must be used only with orifice 22 or orifice 32. Orifices 2, 4, 8 and 13 cannot be used at this differential pressure.

### Body Pressure/Temperature Rating

The chart shows the maximum shell (body) pressure and temperature rating. Operating differential pressure is limited to 650 psi.

### Material/Test Certificates

All inspection requirements must be stated at time of order. Test certificates can be issued on request in accordance with EN 10204 – 2.2 and -3.1B. Heat codes from body and cover are required for certifications.

### Available End Connections

Flanged: ANSI 300, 400 or 600

BW

SW

### How to Order

Specify trap, end connection size and type.

For Example: UNA 27h Duplex A045 2" ANSI 600

# Gestra® Steam Trap • Float and Throstatic Steam Trap

**UNA 38**

**1160**  
psi  
Maximum Δp  
(80 bar)

**Class Rating:** PN 100

**Available Sizes:** 1/2", 1", 1 1/2" and 2"  
(DN 15, 25, 40 and 50)

**Application**

The UNA 38 is designed for medium to high capacity applications where maximum air handling, hot discharge, modulating operation are required. These applications include reboilers, heat exchangers, etc., SST thermostatic element used for automatic deaeration during startup and upset opens an additional orifice for maximum air venting and high cold water capacity for rapid startup.

**Features and Benefits**

- Bolted cover for in-line inspection and maintenance.
- Operation is unaffected by back pressure.
- Duplex design automatically vents non-condensable gases at higher capacity than competitive F&T's using small orifice bypasses.
- Two (2) year guarantee.

**Options**

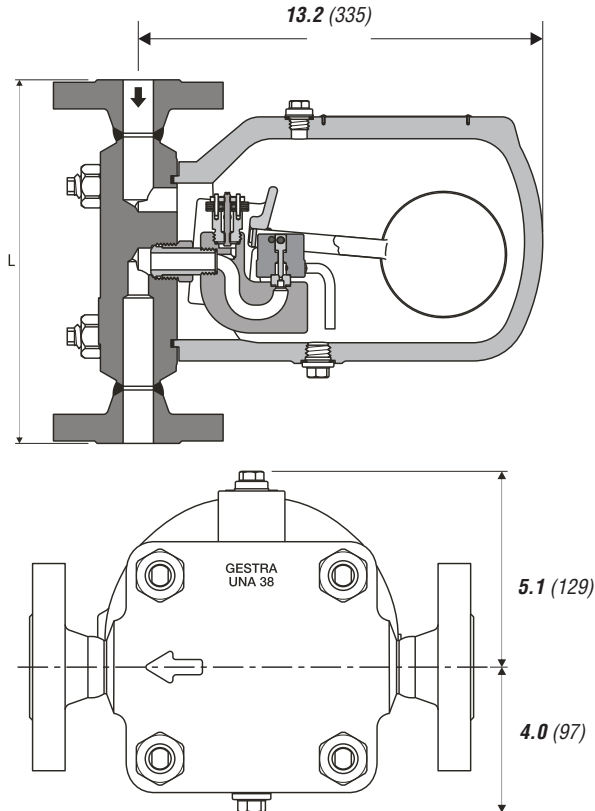
- Hand Vent Lifting Lever for manual purge.
- Vent valve for manual override of air venting or balancing line connection.

**Materials**

- Body and Cover – ASTM A182-F1 (DIN 1.7335)
- Bolts – ASTM A193 B16 (DIN 1.7709)
- Nuts – ASTM A193 B16 (DIN 1.7258)
- Other Internals – StainlessSteel

**Body Pressure/Temperature Rating**

The chart shows the maximum shell (body) pressure and temperature rating. Operating differential pressure is limited to **1,160 psi**.



Dimensions and Weights		End Connections			
Nominal Sizes	[inch] [mm]	1/2 15	1 25	1 1/2 40	2 50
Flanged ANSI 600	L [inch]	11.8	11.8	16.6	16.8
	[mm]	300	300	421	427
Butt-weld	L [inch]	11.8	11.8	11.8	11.8
	[mm]	300	300	300	300
Socket weld	L [inch]	11.8	11.8	16.5	16.5
	[mm]	300	300	420	420
Approx. Weight	[lbs]	77	77	77	77
Butt-weld & Socket weld	[kg]	35	35	35	35

Pressure / Temperature Ratings					
Standard Construction					
Maximum Service Pressure	[psig]	1450	1160	957	638
	[ barg]	100	80	66	44
Related Temperature	[°F]	212	541	752	932
	[°C]	100	283	400	500
Maximum Differential Pressure		1,160 psi (80 bar)			
High Temperature Construction					
Maximum Service Pressure	[psig]	1450	1320	1160	435
	[ barg]	100	91	80	30
Related Temperature	[°F]	212	541	752	986
	[°C]	100	283	400	530
Maximum Differential Pressure		1,160 psi (80 bar)			

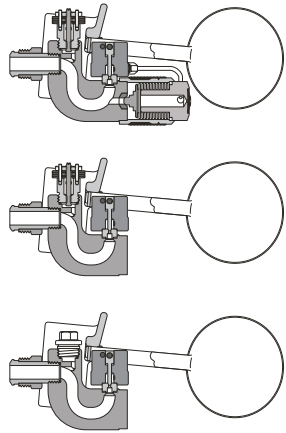
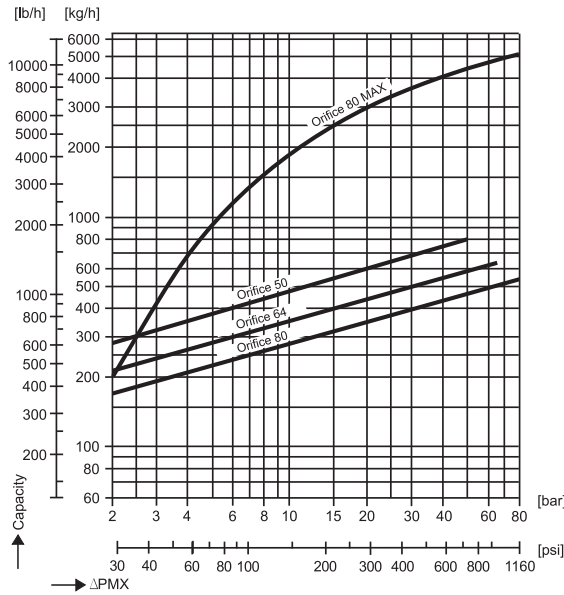
**1160**  
psi  
Maximum  $\Delta p$   
(80 bar)

**Gestra® Steam Trap • Float and Throstatic Steam Trap**

**UNA 38**

**Class Rating:** PN 100

**Available Sizes:** ½", 1", 1½" and 2"  
(DN 15, 25, 40 and 50)



**Capacity Charts**

The charts show the maximum hot water capacities for UNA 38 steam traps. The capacities are a function of differential pressure or the difference between inlet and outlet pressures for the trap. The hotwater capacities are indicated by the solid lines. The cold water (start-up) capacity is indicated by the dashed lines.

**Orifice Number**

The orifice number listed on the capacity line refers to the maximum differential pressure (in bar) for which the UNA 38 with that orifice may be used. Each orifice has a different diameter and will provide a different capacity. Select the line appropriate for the application without exceeding the maximum differential pressure.

**Available End Connections**

Flanged: ANSI 600RF

Socket-weld, Butt weld

NPT

**How to Order**

Specify trap, end connection size and type.

For Example: UNA 38 Duplex A080 1" 600RF

Standard Spare Parts		
Item Number	Description	1/2" - 2"
Q	Body Gasket	524532
E	Duplex Control Unit with body gasket	Orifice 50 560550
H		Orifice 64 560551
		Orifice 80 560552
		Orifice 80 MAX 560553
R	Simplex Control Unit with body gasket	Orifice 50 560554
		Orifice 64 560555
		Orifice 80 560556
		Orifice 80 MAX 560557
I	Hand vent valve with gasket	560559
K	Float lifting lever with gasket	560566
C	Bimetallic air vent EBK 39	560558

# Gestra® Steam Trap • Float and Thermostatic Steam Trap

## UNA Special, Type 62

**230**  
psi  
Maximum Δp  
(16 bar)

**Class Rating:** PN 16

**Available Sizes:** 2½" and 3"  
(DN 65 and 80)

**Application**

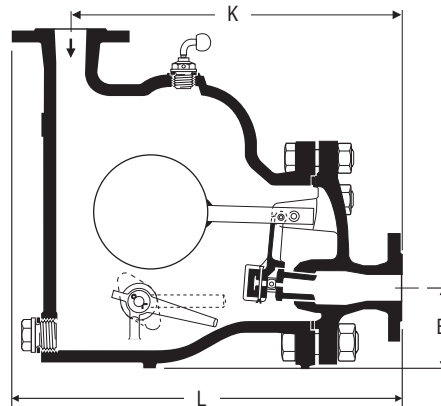
The UNA PN Special, Type 62 float trap is used to drain water or fluids from steam systems, compressed air systems or gas lines.

**Features and Benefits**

- Cast steel body.
- Stainless Steel and Alloy Steel Internals.
- Operation is unaffected by back pressure.
- Useful for heat transfer fluids.
- Drain plug (standard) can be removed and replaced with an AK 45 for automatic drainage during shutdowns.
- Provided with a hand vent valve (standard) for depressurizing the trap body prior to servicing.
- Maximum operating temperature 752°F (400°C).
- Available with different orifices for maximum differential pressures from **30 to 320 psi**.
- Two (2) year guarantee.

**Materials**

- Body and Cover – A126-B (DIN GG-25)
- Fixing studs and Spacer sleeves – A193 B7 (DIN 1.7258)
- Seat – SAE 51420F (DIN 1.4034)
- Slide Valve – A182 F6 (DIN 1.4120)
- Ball float – AISI 430Ti (DIN 1.4510)



Pressure / Temperature Ratings			
Maximum Service Pressure	[psig]	<b>230</b>	<b>185</b>
	[barg]	16	13
Related Temperature	[°F]	<b>248</b>	<b>572</b>
	[°C]	120	300
Maximum Differential Pressure	<b>230 psig (16 barg)</b>		

Dimensions and Weights		End Connections		
		Flanged		
Nominal Sizes	[inch]	2 1/2	3	4
	[mm]	65	80	100
Dimensions	E [inch]	4.1	4.3	4.9
	[mm]	105	110	125
	K [inch]	18.5	19.3	27.6
	[mm]	470	490	700
	L [inch]	22.2	23.2	31.9
	[mm]	563	590	810
Approx. Weight	[lbs]	150	209	440
	[kg]	68	95	200

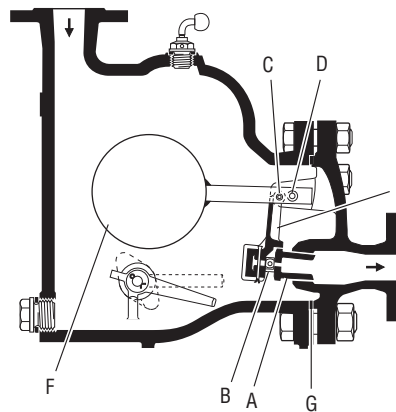
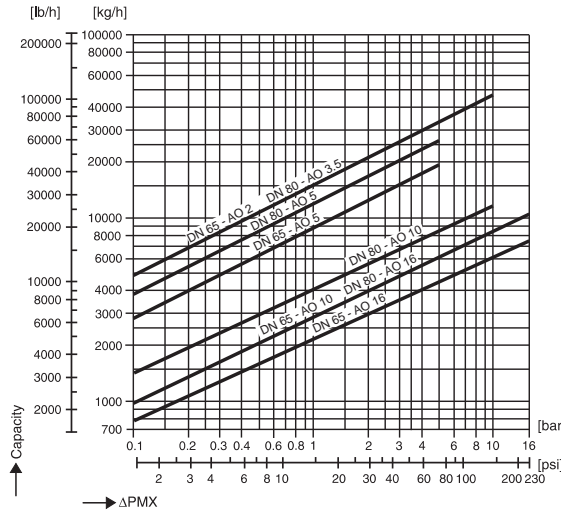
**230**  
psi  
Maximum  $\Delta p$   
(16 bar)

## Gestra® Steam Trap • Float and Throstatic Steam Trap

## UNA Special, Type 62

**Class Rating:** PN 16

**Available Sizes:** 2½" and 3"  
(DN 65 and 80)



*Due to the large number of possible combinations please contact Flowserve Gestra for the recommended spare parts for your trap.*

### Capacity Charts

The charts show the maximum capacities for hot condensate. The capacities are a function of differential pressure or the difference between inlet and outlet pressures for the valve.

The orifice number refers to the maximum differential pressure (in bar) for which the UNA Special, Type 62 may be used as a liquid drainer. Each orifice has a different diameter and will provide a different capacity. Select the line that is most appropriate for the application without exceeding the maximum differential pressure.

The UNA Special, Type 62 is designed for liquids having a specific gravity of 1. Please consult Flowserve Gestra for fluids with different specific gravities.

### Body Pressure/Temperature Rating

The chart shows the maximum shell (body) pressure and temperature rating. Operating differential pressure is limited to **230 psi (16 bar)**.

### Material/Test Certificates

All inspection requirements must be stated at time of order. Test certificates can be issued on request in accordance with EN 10204 – 2.2 and -3.1B. Heat Codes from body and cover are required.

### Available End Connections

Flanges: ANSI 150RF

### How to Order

Specify trap, orifice, end connection size and type.

For Example: UNA Special, Type 62 2½" Duplex Orifice A08



## Gestra® Steam Trap • Float and Throstatic Steam Trap

## UNA Special PN 25

**320**  
psi  
Maximum Δp  
(22 bar)

**Class Rating:** PN 25

**Available Sizes:** 2" and 2½"  
(DN 50 and 65)

### Application

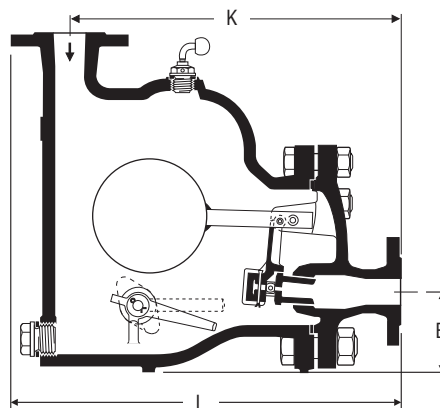
The UNA Special PN 25 float trap is used to drain water or fluids from steam systems, compressed air systems or gas lines.

### Features and Benefits

- Cast steel body.
- Stainless Steel and Alloy Steel Internals.
- Operation is unaffected by back pressure.
- Useful for heat transfer fluids.
- Drain plug (standard) can be removed and replaced with an AK 45 for automatic drainage during shutdowns.
- Provided with a hand vent valve (standard) for depressurizing the trap body prior to servicing.
- Maximum operating temperature 752°F (400°C)
- Available with different orifices for maximum differential pressures from **30 to 320 psi**.
- Two (2) year guarantee.

### Materials

- Body and Cover – A216 WCB (DIN GS-C 25)
- Fixing studs and Spacer sleeves – A193 B7 (DIN 1.7258)
- Seat – SAE 51420F (DIN 1.4034)
- Slide Valve – A182 F6 (DIN 1.4021)
- Ball float – A182 F304 (DIN 1.4301)



Pressure / Temperature Ratings					
Maximum Service Pressure	[psig]	<b>360</b>	<b>320</b>	<b>245</b>	<b>185</b>
	[barg]	25	22	17	13
Related Temperature	[°F]	<b>248</b>	<b>392</b>	<b>572</b>	<b>752</b>
	[°C]	120	200	300	400
Maximum Differential Pressure		<b>320 psig (22 barg)</b>			

Dimensions and Weights		End Connections	
		Flanged	
Nominal Sizes	[inch]	<b>2</b>	<b>2 1/2</b>
	[mm]	50	65
Dimensions	E [inch]	<b>3.9</b>	<b>4.1</b>
	[mm]	100	105
	K [inch]	<b>17.5</b>	<b>18.5</b>
		[mm]	445
	L [inch]	<b>20.7</b>	<b>22.2</b>
		[mm]	527
Approx. Weight	[lbs]	<b>150</b>	<b>181</b>
	[kg]	68	82

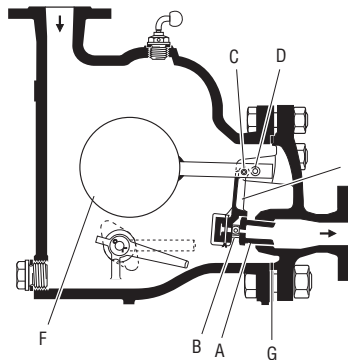
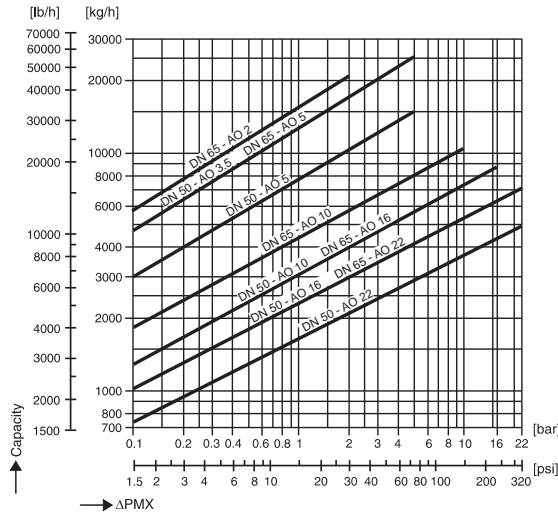
**320**  
psi  
Maximum  $\Delta p$   
(22 bar)

## Gestra® Steam Trap • Float and Throstatic Steam Trap

## UNA Special PN 25

**Class Rating:** PN 25

**Available Sizes:** 2" and 2½"  
(DN 50 and 65)



Standard Spare Parts			
Item Number	Description	UNA PN 25 2"	UNA PN 25 2 1/2"
A	Seat		
	Orifice 2	-	210311
	Orifice 3.5	210325	-
	Orifice 5	210324	210325
	Orifice 10	210336	210337
	Orifice 16	210351	210336
B	Slide Valve		
	Orifice 2	-	210355
	Orifice 3.5	210372	-
	Orifice 5	210371	210372
	Orifice 10	210383	210384
	Orifice 16	210395	210383
E	Side valve rod		
	Simplex	200840	200840
	Duplex	200858	200858
F	Ball float	210452	210453
	Cover gasket	210585	210586

### Capacity Charts

The charts show the maximum capacities for hot condensate. The capacities are a function of differential pressure or the difference between inlet and outlet pressures for the valve.

The orifice number refers to the maximum differential pressure (in bar) for which the UNA Special PN 25 may be used as a liquid drainer. Each orifice has a different diameter and will provide a different capacity. Select the line that is most appropriate for the application without exceeding the maximum differential pressure.

The UNA Special PN 25 is designed for liquids having a specific gravity of 1. Please consult Flowserve Gestra for fluids with different specific gravities.

### Body Pressure/Temperature Rating

The chart shows the maximum shell (body) pressure and temperature rating. Operating differential pressure is limited to **320 psi** (22 bar).

### Material/Test Certificates

All inspection requirements must be stated at time of order. Test certificates can be issued on request in accordance with EN 10204 – 2.2 and -3.1B. Heat Codes from body and cover are required.

### Available End Connections

Flanges: ANSI 150RF

### How to Order

Specify trap, orifice, end connection size and type.

For Example: UNA PN 25 2" Duplex Orifice AO 08



## *Liquid Drainers – UNA*



This page intentionally left blank.

# Gestra® Float Trap • Liquid Drainer

## UNA 14S and UNA 16S

**305**  
psi  
Maximum Δp  
(21 bar)

**Class Rating:** UNA 14S - PN 16  
UNA 16S - PN 25

**Available Sizes:** 1/2", 3/4" and 1"  
(DN 15, 20 and 25)

**Not intended for use as a steam trap.**

UNA 14S: 185 PSI Maximum Δp

UNA 16S: 305 PSI Maximum Δp

**Application**

**UNA 14S and UNA 16S (Simplex):**

Used as a liquid drainer to remove water from air lines.  
Can be inverted and used to remove air from water lines.  
Rugged float trap with stainless steel ball valve mechanism for liquid drainage.

**UNA 14SR and UNA 16SR (Simplex with vent):**

A continuous bleed vent tube in this drainer acts as a steam lock release. Used in rolling drum dryers, tilting kettles, siphon lift applications and other instances where a constant flow is required to prevent steam binding.

**UNA 16SSST:**

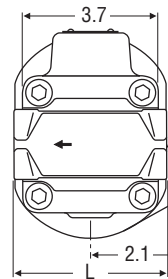
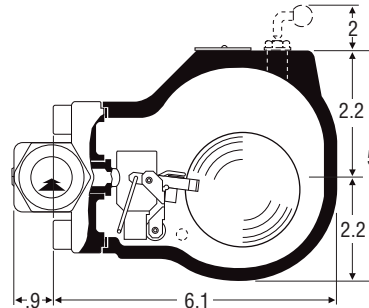
All SST construction. Body – DIN material equivalent to ASTM A182. Cover – DIN material equivalent to ASTM A351 CF 8.

**Features and Benefits**

- Bolted cover for in-line inspection and maintenance.
- Easily field-converted from horizontal (H) to vertical (V) to reduce inventories.
- Useful for other heat transfer fluids.
- Operation is unaffected by back pressure.
- Rolling ball valve mechanism ensures smooth operation with no sticking and minimum wear. Internal SST shielding prevents body damage from outlet flows.
- Hand Vent Valve Option
- Two (2) year guarantee.

**Materials**

- UNA 14 – Body – ASTM A105 (DIN 1.0460)  
Cover – A536 60-40-48 (EN-JS-1049)
- UNA 16 – Body – ASTM A105 (DIN 1.0460)  
Cover – ASTM A216 WCB (DIN 1.0619)
- UNA 16A – Body – ASTM A182 F316L (DIN 1.4404)  
Cover – ASTM A351 CF 8 (DIN 1.4308)
- All Other Internals – Stainless Steel



**Pressure / Temperature Ratings**

Body Style	UNA 14				
Maximum Service Pressure	[psig] [barg]	368 25	285 19.4	262 17.8	221 15
Related Temperature	[°F] [°C]	68 20	392 200	482 250	662 350
Maximum Differential Pressure	185 psi (13 bar)				

Body Style	UNA 16				UNA 16A				
Maximum Service Pressure	[psig] [barg]	254 17.3	203 13.8	150 10.2	96 6.5	284 19.3	250 17	206 14	150 10.2
Related Temperature	[°F] [°C]	68 20	392 200	572 300	752 400	68 20	212 100	392 200	572 300
Maximum Differential Pressure	320 psi (22 bar)				320 psi (22 bar)				

Dimensions and Weights		Nominal Sizes		
		1/2	3/4	1
End Connections	[inch] [mm]	15 15	20 20	25 25
Flanged L	[inch] [mm]	5.9 150	5.9 150	6.3 160
Butt-Weld L	[inch] [mm]	7.9 200	7.9 200	7.9 200
Socketweld L	[inch] [mm]	3.7 95	3.7 95	3.7 95
Approx. Weight	Flanged [lbs]	13	14	15
	[kg]	6	6.5	7
	S.W., B.W. [lbs]	10	10	3
	Screwed [kg]	4.5	4.5	1.5

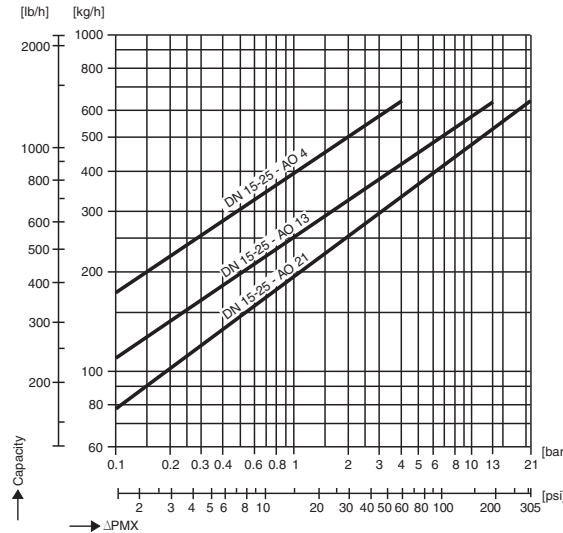
**305**  
psi  
Maximum  $\Delta p$   
(21 bar)

## Gestra® Float Trap • Liquid Drainer

## UNA 14S and UNA 16S

**Class Rating:** UNA 14S - PN 16  
UNA 16S - PN 25

**Available Sizes:** ½", ¾" and 1"  
(DN 15, 20 and 25)



### Capacity Charts

The charts show the maximum capacities of hot water based on the orifice of the liquid drainers. The capacities are a function of differential pressure or the difference between inlet and outlet pressures for the trap. The maximum differential pressure of the UNA 14S is **185 psi**. For differential pressure greater than **185 psi**, The UNA 16S must be chosen. The cold water capacity is between 1.1 and 1.7 times the hot capacity, depending on the differential pressure. Please contact Flowserve Gestra for these capacities or for use with other fluids.

### Orifice Number

The orifice number listed on the capacity curve refers to the maximum differential pressure (in bar) for which the UNA 14S/16S with that orifice may be used. Each orifice has a different diameter and will provide a different capacity. Select the curve which is appropriate for the application without exceeding the maximum differential pressure.

**NOTE:** At a **200 psi** differential, the UNA 16S must be used only with orifice 21. Orifices 4 or 13 cannot be used at this differential pressure.

### Body Pressure/Temperature Rating

The chart shows the maximum shell (body) pressure and temperature rating. Operating differential pressure is limited to **185 psi** for the UNA 14S and **305 psi** for the UNA 16S.

### Material/Test Certificates

All inspection requirements must be stated at time of order. Test certificates can be issued on request in accordance with EN 10204 – 2.2 and -3.1B. Heat codes from body and cover are required for certifications.

### Available End Connections

NPT, BW, SW

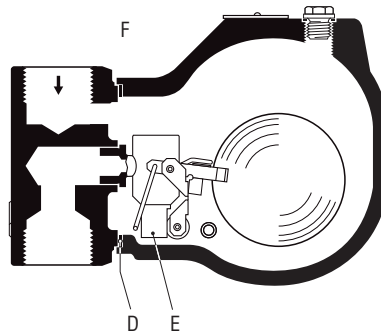
Flanged: ANSI 150, 300 (UNA 16S ANSI 300 only)

### How to Order

Specify drainer, initial orientation, end connection size and orifice. Horizontal (H) provided as standard initial orientation. Please specify if vertical (V) initial orientation is desired.

For Example: UNA 16hS A013 1" NPT

If ANSI flanged ends required, please specify either ANSI 150 RF or ANSI 300 RF.



Standard Spare Parts			
Item Number	Description	UNA 14	UNA 16
Da	Simplex Control Unit		
	R Orifice 4	560413	560413
	R Orifice 13	560412	560412
	R Orifice 21	-	560411
Db	Simplex Control Unit		
	Orifice 4	560416	560416
	Orifice 13	560415	560415
	Orifice 21	-	560414
F	Thermostatic Capsule (5N2)	099509	099509
G	Cover Gasket	522752	522754

# Gestra® Float Trap • Liquid Drainer

## UNA 14P

**230**

psi  
Maximum Δp  
(16 bar)

**Class Rating:** UNA 14p - PN 16

**Available Sizes:** 1/2", 3/4" and 1"  
(DN 15, 20 and 25)

**Not intended for use as a steam trap.**

UNA 14p: 230 Maximum Δp

**Application**

**UNA 14P (Simplex with Perbunan ball):**

Same as the 14/16 except the SST ball is replaced with a Perbunan (Buna-N) ball for improved air closure.

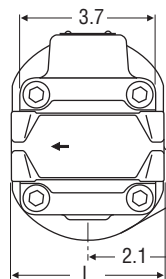
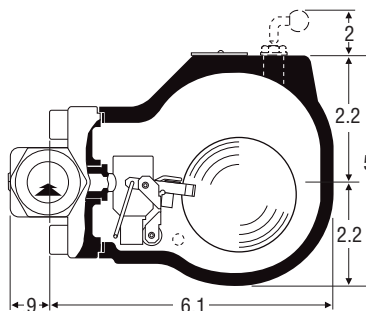
Temperature and pH limitations apply. Please consult with your local Flowserve Gestra representative.

**Features and Benefits**

- Bolted cover for in-line inspection and maintenance.
- Easily field-converted from horizontal (H) to vertical (V) to reduce inventories.
- Useful for other heat transfer fluids.
- Operation is unaffected by back pressure.
- Rolling ball valve mechanism ensures smooth operation with no sticking and minimum wear. Internal SST shielding prevents body damage from outlet flows.
- Hand Vent Valve Option
- Two (2) year guarantee.

**Materials**

- Body and Cover – Cast Iron A126 Cl B (DIN 0.6025)
- All Other Internals – Stainless Steel



Pressure / Temperature Ratings		
With <b>Perbunan</b> valve ball		UNA 14p
Maximum Service Pressure	[psig] [barg]	<b>230</b> 16
Related Temperature	[°F] [°C]	<b>104</b> 40
Maximum Differential Pressure		<b>230 psi (16 bar)</b>
With <b>Steel</b> valve ball		UNA 14p
Maximum Service Pressure	[psig] [barg]	<b>230</b> 16
Related Temperature	[°F] [°C]	<b>248</b> 120
Maximum Differential Pressure		<b>230 psi (16 bar)</b>

Dimensions and Weights		Nominal Sizes			
End Connections	[inch]	<b>1/2</b>	<b>3/4</b>	<b>1</b>	
	[mm]	15	20	25	
Flanged L	[inch]	<b>5.9</b>	<b>5.9</b>	<b>6.3</b>	
	[mm]	150	150	160	
Butt-Weld L	[inch]	<b>7.9</b>	<b>7.9</b>	<b>7.9</b>	
	[mm]	200	200	200	
Socketweld L Screwed	[inch]	<b>3.7</b>	<b>3.7</b>	<b>3.7</b>	
	[mm]	95	95	95	
Approx. Weight	Flanged	[lbs]	<b>13</b>	<b>14</b>	<b>15</b>
		[kg]	6	6.5	7
	S.W., B.W.	[lbs]	<b>10</b>	<b>10</b>	<b>3</b>
		[kg]	4.5	4.5	1.5

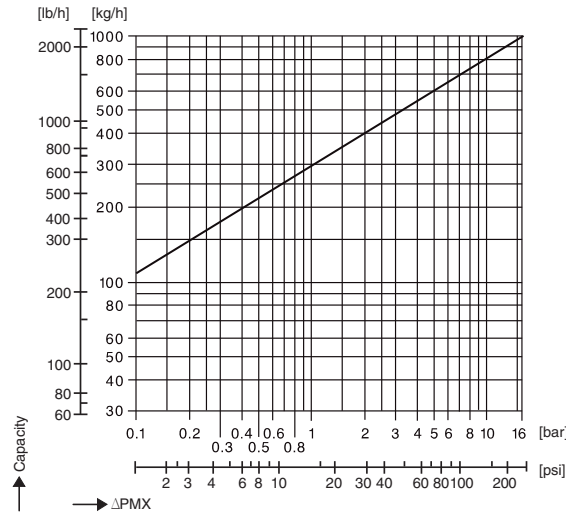
**230**  
psi  
Maximum  $\Delta p$   
(16 bar)

**Gestra® Float Trap •  
Liquid Drainer**

**UNA 14P**

**Class Rating:** UNA 14p - PN 16

**Available Sizes:** ½", ¾" and 1"  
(DN 15, 20 and 25)



**Capacity Charts**

The charts show the maximum capacities of cold water based on the orifice of the liquid drainers. The capacities are a function of differential pressure or the difference between inlet and outlet pressures for the trap.

**Orifice Number**

The orifice number listed on the capacity curve refers to the maximum differential pressure (in bar) for which the UNA 14p may be used.

**Body Pressure/Temperature Rating**

The chart shows the maximum shell (body) pressure and temperature rating. Operating differential pressure is limited to **230 psi**.

**Material/Test Certificates**

All inspection requirements must be stated at time of order. Test certificates can be issued on request in accordance with EN 10204 – 2.2 and -3.1B. Heat codes from body and cover are required for certifications.

**Available End Connections**

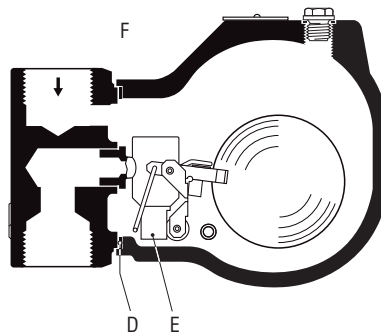
NPT

Flanged: ANSI 150

**How to Order**

Specify drainer, initial orientation, end connection size and orifice. Horizontal (H) provided as standard initial orientation. Please specify if vertical (V) initial orientation is desired.

For Example: UNA 14hp A016 1" NPT



Standard Spare Parts		
Item Number	Description	UNA 14
D	Control Unit with Perbunan Ball Orifice 16	560418
G	Cover Gasket	522752



# Gestra® Float Trap • Liquid Drainer

## UNA 26H

**465**  
psi  
Maximum Δp  
(32 bar)

**Class Rating:** PN 40

**Available Sizes:** 1/2", 3/4", 1", 1 1/2" and 2"  
(DN 15, 20, 25, 40 and 50)

**Not intended for use as a steam trap.**

### Application

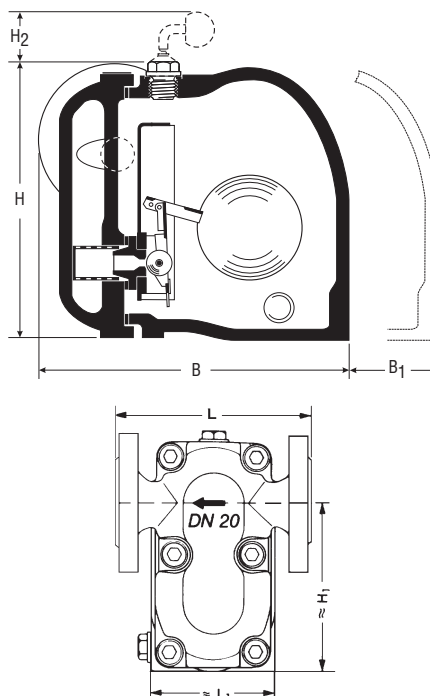
The UNA 26 is useful as a liquid drainer to remove water from air lines. Can be inverted and used to remove air from water lines. Rugged float trap with stainless steel ball valve mechanism for liquid drainage.

### Features and Benefits

- Bolted cover for in-line inspection and maintenance.
- Operation is unaffected by back pressure.
- Rolling ball valve mechanism ensures smooth operation with no sticking and minimum wear.
- Useful for heat transfer fluids.
- Optional ball lifting lever available.
- Optional hand vent valve available.
- Two (2) year guarantee.

### Materials

- Body and Cover – ASTM-A216 WCB (DIN 1.0619)
- Bolts – ASTM A193 B16 (DIN 1.7709)
- Nuts – ASTM A193 B16 (DIN 1.7258)
- Other Internals – Stainless Steel



Dimensions and Weights		End Connections				
Nominal Sizes	[inch]	1/2	3/4	1	1 1/2	2
	[mm]	15	20	25	40	50
Dimensions	B [inch]	7.4	7.6	7.8	11.6	11.9
	[mm]	187	192	197	294	302
	B1 [inch]	5	5	5	8	8
	[mm]	130	130	130	200	200
	H [inch]	7	7	7	13	13
	[mm]	184	184	184	318	318
H1 [inch]	5	5	5	9	9	
	[mm]	126	126	126	219	219
H2 [inch]	1.5	1.5	1.5	1.5	1.5	
	[mm]	38	38	38	38	38
Flanged	L [inch]	8.3	8.3	9.1	12.6	12.6
	[mm]	210	210	230	320	320
Butt-weld	L [inch]	7.9	7.9	7.9	9.1	9.1
	[mm]	200	200	200	230	230
Socket-weld	L [inch]	7.9	7.9	7.9	9.1	9.1
	[mm]	200	200	200	230	230
Screwed	L [inch]	7.9	7.9	7.9	10	10
		[mm]	200	200	200	255
	L1 [inch]	3.7	3.7	3.7	6.1	6.1
		[mm]	94	94	94	154
Approx. Weight	[lbs]	21	22	23	66	68
	[kg]	9.5	10	10.5	30	31

# 465

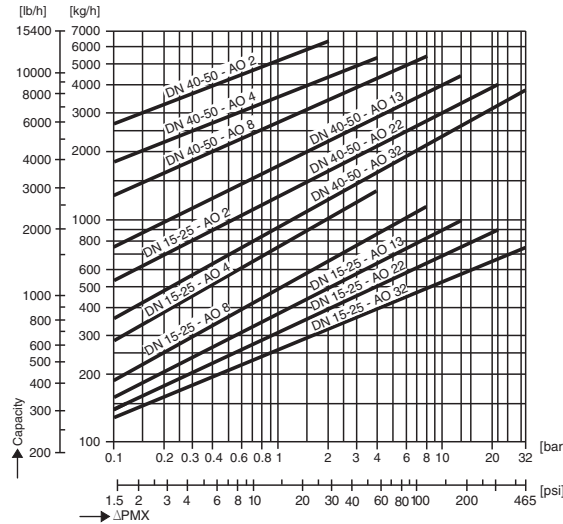
psi  
Maximum  $\Delta p$   
(32 bar)

## Gestra® Float Trap • Liquid Drainer

### UNA 26H

**Class Rating:** PN 40

**Available Sizes:** 1/2", 3/4", 1", 1 1/2" and 2"  
(DN 15, 20, 25, 40 and 50)



#### Capacity Charts

The charts show the maximum hot water capacities for UNA 26S steam traps. The capacities are a function of differential pressure or the difference between inlet and outlet pressures for the trap. For cold water and other fluids, please consult your local Flowserve Gestra representative.

#### Orifice Number

The orifice number listed on the capacity line refers to the maximum differential pressure for which the UNA 26S with that orifice may be used. Each orifice has a different diameter and will provide a different capacity. Select the line which is appropriate for the application without exceeding the maximum differential pressure.

**NOTE:** At a 200 psi differential, the UNA 26S must be used only with orifice 22 or orifice 32. Orifices 2, 4, 8, and 13 cannot be used at this differential pressure.

#### Body Pressure/Temperature Rating

The chart shows the maximum shell (body) pressure and temperature rating. Operating differential pressure is limited to 465 psi for the UNA 26S.

#### Material/Test Certificates

All inspection requirements must be stated at time of order. Test certificates can be issued on request in accordance with EN 10204 – 2.2 and -3.1B. Heat codes from body and cover are required for certifications.

#### Available End Connections

NPT

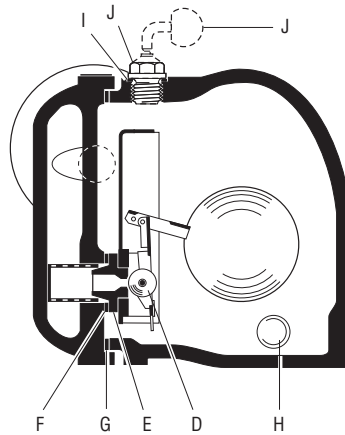
Flanged: ANSI 150RF, 300RF

BW, SW

#### How to Order

Specify drainer, end connection, size and orifice.

For Example: UNA 26H Simplex A022 1" NPT



Standard Spare Parts		
Item Number	Description	UNA 26
D	Control Unit	Varies with orifice
E	Seat	Varies with orifice
F	Seat Gasket	1/2" - 1" 522388
		1 1/2" - 2" 522389
G	Cover Gasket	1/2" - 1" 522243
		1 1/2" - 2" 522244
H	Optional Float Lifting Lever	1/2" - 1" 560061
		1 1/2" - 2" 560062
I	Plug Gasket	013849
J	Plug (3/8" BSP) Optional Hand Vent Valve	012537
		560058

# Gestra® Float Trap • Liquid Drainer

UNA 27H

**650**  
psi  
Maximum Δp  
(45 bar)

**Class Rating:** PN 63

**Available Sizes:** 1", 1½" and 2"  
(DN 25, 40 and 50)

**Not intended for use as a steam trap.**

**Application**

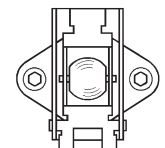
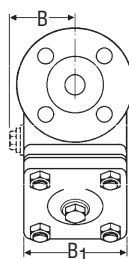
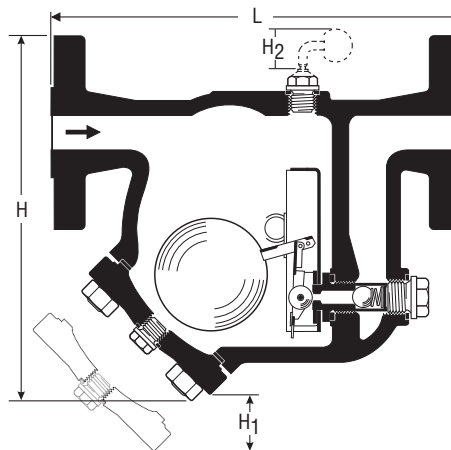
The UNA 27h is useful as a liquid drainer to remove water from air lines. Can be inverted and used to remove air from water lines. Rugged float trap with stainless steel ball valve mechanism for liquid drainage.

**Features and Benefits**

- Horizontal (h) orientation only.
- Bolted cover for in-line inspection and maintenance.
- Operation is unaffected by back pressure.
- Rolling ball valve mechanism ensures smooth operation with no sticking and minimum wear.
- Useful for heat transfer fluids.
- Optional lifting lever available to manually purge.
- Optional hand vent valve available.
- Two (2) year guarantee.

**Materials**

- Body and Cover – ASTM A217 WC1 (DIN 1.5419)
- Cover Screws – ASTM A193 B16 (DIN 1.7709)
- Nuts – ASTM A193 B7 (DIN 1.7258)
- Other Internals – Stainless Steel



View of Rolling  
Stainless Steel Ball

Dimensions and Weights		End Connections		
Nominal Sizes	[inch]	1	1 1/2	2
	[mm]	25	40	50
Dimensions	B [inch]	3.1	4.4	4.4
	[mm]	80	111	111
	B1 [inch]	5	9	9
	[mm]	126	225	225
	H [inch]	11	17	17
	[mm]	278	420	420
H1 [inch]	2	2	2	
	[mm]	50	50	50
H2 [inch]	1.6	1.6	1.6	
	[mm]	40	40	40
Flanged ANSI 300	L [inch]	11.3	15.9	16.1
	[mm]	287	405	408
Flanged ANSI 400/600	L [inch]	11.8	16.6	16.8
	[mm]	300	421	427
Butt-weld	L [inch]	11.8	16.5	16.5
	[mm]	300	420	420
Approx. Weight	[lbs]	44	119	121
	[kg]	20	54	55

**650**

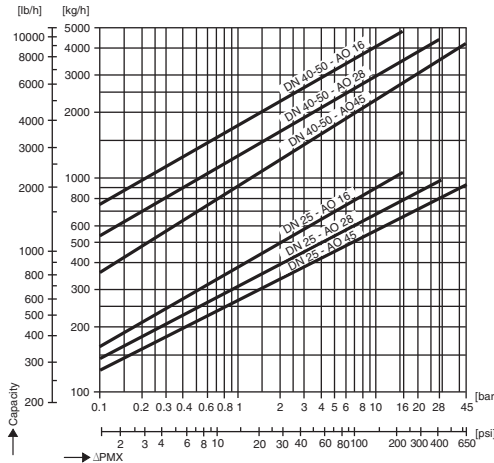
psi  
Maximum  $\Delta p$   
(45 bar)

**Gestra® Float Trap •  
Liquid Drainer**

**UNA 27H**

**Class Rating:** PN 63

**Available Sizes:** 1", 1½" and 2"  
(DN 25, 40 and 50)



**Capacity Charts**

The charts show the maximum capacities for hot water. The capacities are a function of differential pressure or the difference between inlet and outlet pressures for the trap. For example, at a **200 psi** differential, the 1" UNA 27hS with an orifice 28 has a hot water capacity of about 1,700 lb/hr. For cold water and other fluids, please consult your local Flowserve Gestra representative.

**Orifice Number**

The orifice number listed on the capacity line refers to the maximum differential pressure (in bar) for which the UNA27hS with that orifice may be used. Each orifice has a different diameter and will provide a different capacity. Select the line which is appropriate for the application without exceeding the maximum differential pressure.

**NOTE:** At a **200 psi** differential, the UNA 26hS must be used only with orifice 22 or orifice 32. Orifices 2, 4, 8 and 13 cannot be used at this differential pressure.

Pressure / Temperature Ratings					
Maximum Service Pressure	[psig]	<b>915</b>	<b>810</b>	<b>680</b>	<b>650</b>
	[barg]	63	56	47	45
Related Temperature	[°F]	<b>482</b>	<b>572</b>	<b>752</b>	<b>842</b>
	[°C]	250	300	400	450
Maximum Differential Pressure	<b>650 psig (45 barg)</b>				

**Body Pressure/Temperature Rating**

The chart shows the maximum shell (body) pressure and temperature rating. Operating differential pressure is limited to **650 psi**.

**Material/Test Certificates**

All inspection requirements must be stated at time of order. Test certificates can be issued on request in accordance with EN 10204 – 2.2 and -3.1B. Heat codes from body and cover are required for certifications.

**Available End Connections**

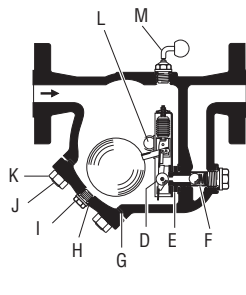
Flanged: ANSI 300RF, 400RF, 600RF

BW, SW

**How to Order**

Specify trap, end connection size, type and orifice.

For Example: UNA 27h Simplex A045 2" ANSI 600



Standard Spare Parts			
Item Number	Description	UNA 27h	
D	Control Unit	Varies with orifice	
E	Seat	Varies with orifice	
F	Check Valve	1"	560406
		1 1/2" - 2"	560407
G	Cover Gasket	1"	522247
		1 1/2" - 2"	522248
H	Drain Plug Gasket	012579	
I	Optional Drain Plug	012576	
J	Cover Bolts	1"	012578
		1 1/2" - 2"	012562
K	Nuts	010168	
L	Optional Float Lifting Lever	1"	560063
		1 1/2" - 2"	560064
M	Optional Hand Vent Valve & Gasket	560059	

# Gestra® Float Trap • Liquid Drainer

UNA 38

**1160**  
psi  
Maximum Δp  
(80 bar)

**Class Rating:** ANSI 600

**Available Sizes:** ½", 1", 1 ½ and 2"  
(DN 15, 25, 40 and 50)

**Not intended for use as a steam trap.**

### Application

The UNA 38 steam trap is used to drain water or fluids from high pressure compressed air or gas lines.

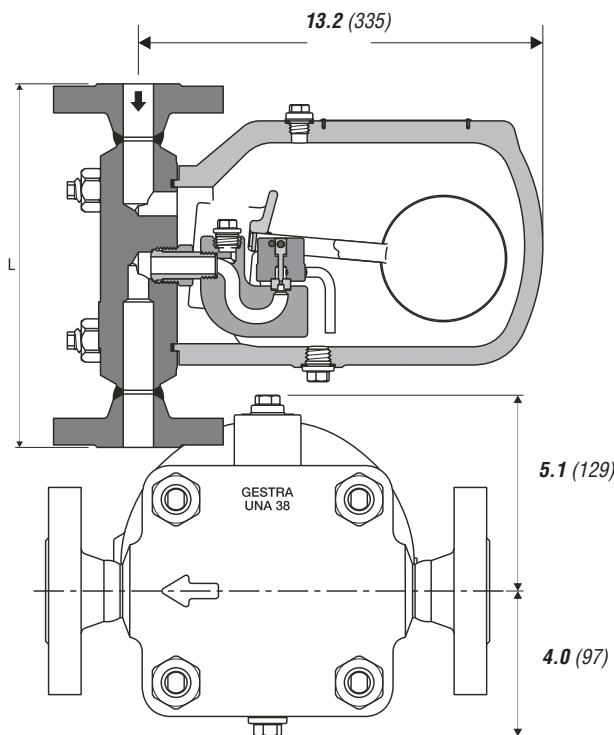
When inverted, the UNA 38 can also be used to vent gases or air from water or fluid lines.

### Features and Benefits

- Forged alloy steel body.
- Stainless Steel Internals.
- Operation is unaffected by back pressure.
- Useful for heat transfer fluids.
- Drain plug (standard) can be removed and replaced with optional lifting lever for manual purging.
- Hardened stainless steel valve needle and seat for long service life.
- Easy in-line inspection and maintenance - no need to remove the trap from the piping to replace the internals.
- Maximum operating temperature 986°F (530°C)
- Available with different orifices for maximum differential pressures of **725, 928, and 1,160 psi**.
- Two (2) year guarantee.

### Materials

- Body and Cover – ASTM- A182 F12 (DIN 1.7335)
- Fixing studs and Spacer sleeves – ASTM-A193 B16 (DIN 1.7709)
- Nuts – ASTM A193 B7 (DIN 1.7258)
- Control Unit – Stainless Steel



Pressure / Temperature Ratings					
Standard Construction					
Maximum Service Pressure	[psig] [barg]	1450 100	1160 80	957 66	638 44
Related Temperature	[°F] [°C]	212 100	541 283	752 400	932 500
Maximum Differential Pressure		1,160 psi (80 bar)			
High Temperature Construction					
Maximum Service Pressure	[psig] [barg]	1450 100	1320 91	1160 80	435 30
Related Temperature	[°F] [°C]	212 100	541 283	752 400	986 530
Maximum Differential Pressure		1,160 psi (80 bar)			

Dimensions and Weights		End Connections			
Nominal Sizes	[inch] [mm]	1/2 15	1 25	1 1/2 40	2 50
Flanged ANSI 600	L [inch] [mm]	11.8 300	11.8 300	16.6 421	16.8 427
Butt-weld	L [inch] [mm]	11.8 300	11.8 300	11.8 300	11.8 300
Socket weld	L [inch] [mm]	11.8 300	11.8 300	16.5 420	16.5 420
Approx. Weight	[lbs] [kg]	77 35	77 35	77 35	77 35
Butt-weld & Socket weld					

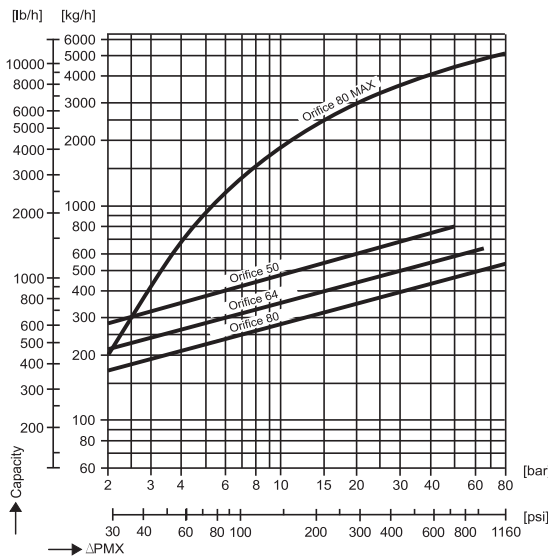
**1160**  
psi  
Maximum  $\Delta p$   
(80 bar)

**Gestra® Float Trap •  
Liquid Drainer**

**UNA 38**

**Class Rating:** ANSI 600

**Available Sizes:** ½", 1", 1 ½" and 2"  
(DN 15, 25, 40 and 50)



**Capacity Charts**

The charts show the maximum capacities for hot condensate. The capacities are a function of differential pressure or the difference between inlet and outlet pressures for the valve.

The orifice number refers to the maximum differential pressure (in bar) for which the UNA 39 may be used as a liquid drainer. Each orifice has a different diameter and will provide a different capacity. Select the line that is most appropriate for the application without exceeding the maximum differential pressure.

The UNA 38 is designed for liquids having a specific gravity of 1. Please consult Flowserve Gestra for fluids with different specific gravities.

**Body Pressure/Temperature Rating**

The chart shows the maximum shell (body) pressure and temperature rating. Operating differential pressure is limited to **1,160 psi (80 bar)**.

**Material/Test Certificates**

All inspection requirements must be stated at time of order. Test certificates can be issued on request in accordance with EN 10204 – 2.2 and -3.1B. Heat Codes from body and cover are required.

**Available End Connections**

Flanges: ANSI 600

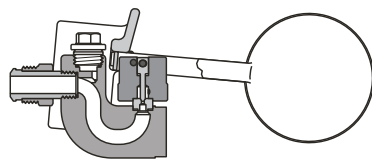
Butt weld and Socketweld

Other connections upon request.

**How to Order**

Specify trap, orifice, end connection size and type.

For Example: UNA 38 2" Orifice 80, BW



Dimensions and Weights		End Connections			
Nominal Sizes	[inch] [mm]	1/2 15	1 25	1 1/2 40	2 50
Flanged ANSI 600	L [inch]	11.8	11.8	16.6	16.8
	[mm]	300	300	421	427
Butt-weld	L [inch]	11.8	11.8	11.8	11.8
	[mm]	300	300	300	300
Socket weld	L [inch]	11.8	11.8	16.5	16.5
	[mm]	300	300	420	420
Approx. Weight	[lbs]	77	77	77	77
Butt-weld & Socket weld	[kg]	35	35	35	35

# Gestra® Float Trap • Liquid Drainer

UNA 39

**2030**  
psi  
Maximum Δp  
(140 bar)

**Class Rating:** PN 160

**Available Sizes:** 1" and 2"  
(DN 25 and 50)

**Not intended for use as a steam trap.**

**Application**

The UNA 39 steam trap is used to drain water or fluids from high pressure compressed air or gas lines.

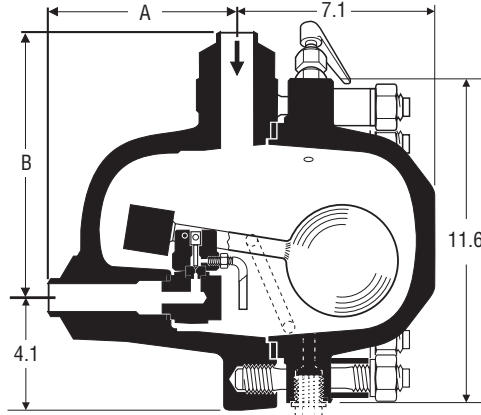
When inverted, the UNA 39 can also be used to vent gases or air from water or fluid lines.

**Features and Benefits**

- Forged alloy steel body.
- Stainless Steel Internals.
- Operation is unaffected by back pressure.
- Useful for heat transfer fluids.
- Drain plug (standard) can be removed and replaced with optional lifting lever for manual purging.
- Provided with a hand vent valve (standard) for depressurizing the trap body prior to servicing.
- Hardened stainless steel valve needle and seat for long service life.
- Easy in-line inspection and maintenance - no need to remove the trap from the piping to replace the internals.
- Maximum operating temperature 752°F (400°C)
- Available with different orifices for maximum differential pressures of **1,160, 1,595 and 2,030 psi**.
- Two (2) year guarantee.

**Materials**

- Body and Cover – ASTM- A182 F12 (DIN 1.7335)
- Fixing studs and Spacer sleeves – ASTM-A193 B16 (DIN 1.7709)
- Nuts – ASTM A193 B7 (DIN 1.7258)
- Control Unit – A276 Gr. 440 B (DIN 1.4112)
- Other Internals – Stainless Steel



Pressure / Temperature Ratings				
Maximum Service Pressure	[psig]	<b>2,320</b>	<b>2,030</b>	<b>510</b>
	[barg]	160	140	35
Related Temperature	[°F]	<b>572</b>	<b>828</b>	<b>1022</b>
	[°C]	300	442	550
Maximum Differential Pressure	<b>2,030 psig (140 barg)</b>			

Dimensions and Weights		End Connections		
Nominal Sizes	[inch]	<b>1/2</b>	<b>1</b>	<b>2</b>
	[mm]	15	25	50
Flanged ANSI 400/600	A [inch]	<b>9.1</b>	<b>9.5</b>	<b>9.9</b>
	[mm]	231.8	241.5	252.7
	B [inch]	<b>12</b>	<b>12</b>	<b>13</b>
	[mm]	301.8	311.5	322.7
Flanged ANSI 900/1500	A [inch]	<b>9.4</b>	<b>9.9</b>	<b>11.1</b>
	[mm]	240.0	252.7	281.1
	B [inch]	<b>12</b>	<b>13</b>	<b>14</b>
	[mm]	310.0	322.7	351.1
Butt-weld	A [inch]	<b>6.7</b>	<b>6.7</b>	<b>6.7</b>
	[mm]	170	170	170
	B [inch]	<b>9.4</b>	<b>9.4</b>	<b>9.4</b>
	[mm]	240	240	240
Approx. Weight	[lbs]	<b>143</b>	<b>143</b>	<b>143</b>
Butt-weld	[kg]	65	65	65

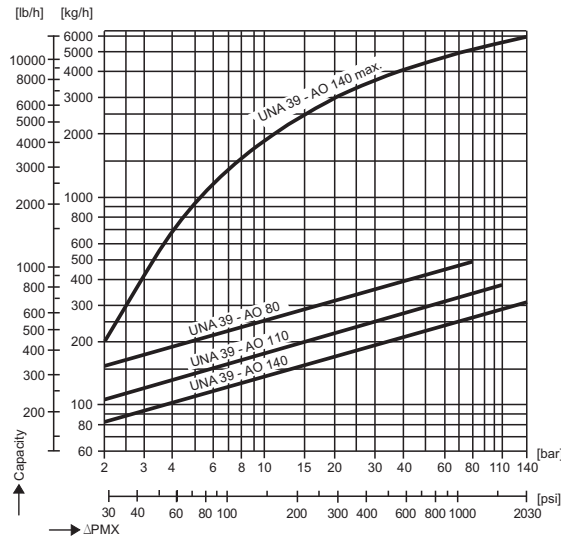
**2030**  
psi  
Maximum  $\Delta p$   
(140 bar)

## Gestra® Float Trap • Liquid Drainer

**UNA 39**

**Class Rating:** PN 160

**Available Sizes:** 1" and 2"  
(DN 25 and 50)



### Capacity Charts

The charts show the maximum capacities for hot condensate. The capacities are a function of differential pressure or the difference between inlet and outlet pressures for the valve.

The orifice number refers to the maximum differential pressure (in bar) for which the UNA 39 may be used as a liquid drainer. Each orifice has a different diameter and will provide a different capacity. Select the line that is most appropriate for the application without exceeding the maximum differential pressure.

The UNA 39 is designed for liquids having a specific gravity of 1. Please consult Flowserve Gestra for fluids with different specific gravities.

### Body Pressure/Temperature Rating

The chart shows the maximum shell (body) pressure and temperature rating. Operating differential pressure is limited to **2,030 psi (140 bar)**.

### Material/Test Certificates

All inspection requirements must be stated at time of order. Test certificates can be issued on request in accordance with EN 10204 – 2.2 and -3.1B. Heat Codes from body and cover are required.

### Available End Connections

Flanges: ANSI 400/600, 900/1500

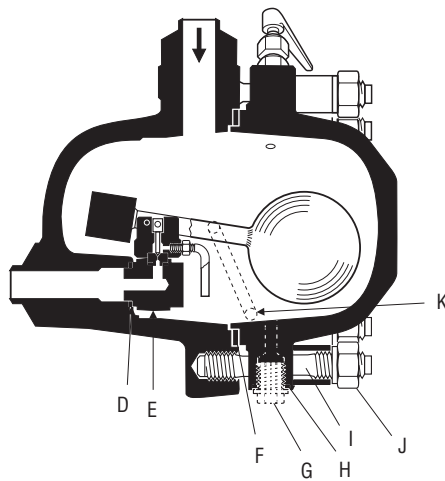
Butt weld

Other connections upon request.

### How to Order

Specify trap, orifice, end connection size and type.

For Example: UNA 39 2" Orifice 8, BW



Standard Spare Parts		
Item Number	Description	UNA 39
D	Valve Seat Gasket	515692
E	Control Unit	
	Orifice 80	560172
	Orifice 110	560171
	Orifice 140	560170
F	Cover Gasket	522249
G	Drain Plug	012580
H	Drain Plug Gasket	012088
I	Studs	012644
J	Nuts	011039
K	Float Lifting Lever	550150



# Gestra® Float Trap • Liquid Drainer

## UNA Special, Type 62

**230**  
psi  
Maximum Δp  
(16 bar)

**Class Rating:** PN 16

**Available Sizes:** 2½", 3" and 4"  
(DN 65, 80 and 100)

**Not intended for use as a steam trap.**

### Application

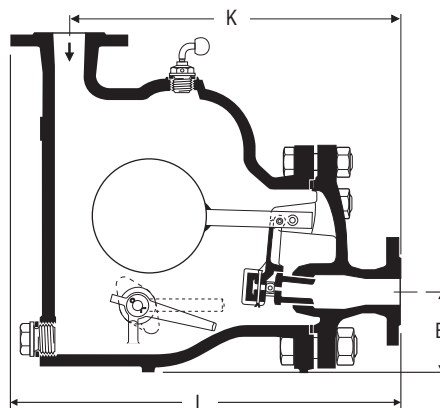
The UNA Special, Type 62 float trap is used to drain water or fluids from steam systems, compressed air systems or gas lines.

### Features and Benefits

- Grey Cast Iron body.
- Stainless Steel and Alloy Steel Internals.
- Operation is unaffected by back pressure.
- Useful for heat transfer fluids.
- Drain plug (standard) can be removed and replaced with an AK 45 for automatic drainage during shutdowns.
- Provided with a hand vent valve (standard) for depressurizing the trap body prior to servicing.
- Maximum operating temperature 752°F (400°C)
- Available with different orifices for maximum differential pressures from **30 to 320 psi**.
- Two (2) year guarantee.

### Materials

- Body and Cover – A216-B (DIN GG-25)
- Fixing studs and Spacer sleeves – A193 B7 (DIN 1.7258)
- Seat – SAE 51420F (DIN 1.4034)
- Slide Valve – A182 F6 (DIN 1.4120)
- Ball float – AISI 430Ti (DIN 1.4510)



Pressure / Temperature Ratings			
Maximum Service Pressure	[psig]	<b>230</b>	<b>185</b>
	[barg]	16	13
Related Temperature	[°F]	<b>248</b>	<b>572</b>
	[°C]	120	300
Maximum Differential Pressure		<b>230 psig (16 barg)</b>	

Dimensions and Weights		End Connections			
		Flanged			
Nominal Sizes	[inch]	2 1/2	3	4	
	[mm]	65	80	100	
Dimensions	E	[inch]	4.1	4.3	4.9
		[mm]	105	110	125
	K	[inch]	18.5	19.3	27.6
		[mm]	470	490	700
	L	[inch]	22.2	23.2	31.9
		[mm]	563	590	810
Approx. Weight	[lbs]	150	209	440	
	[kg]	68	95	200	

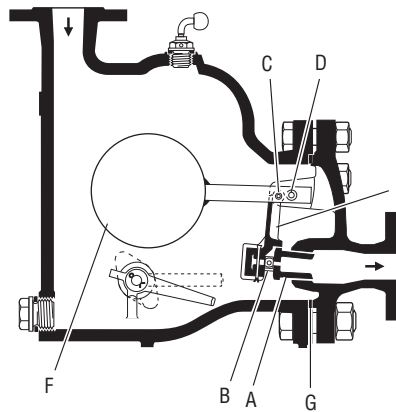
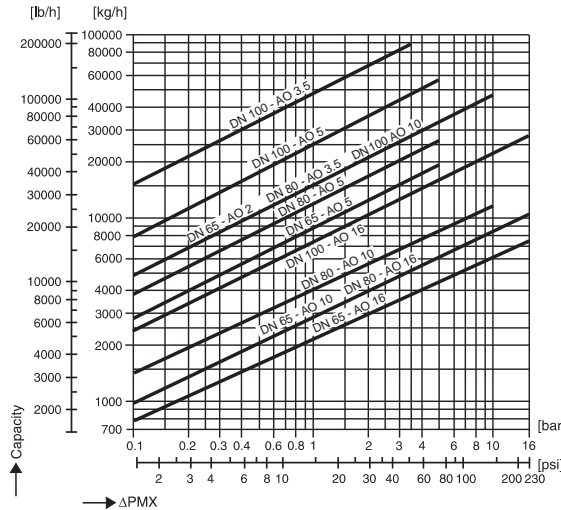
**230**  
psi  
Maximum  $\Delta p$   
(16 bar)

## Gestra® Float Trap • Liquid Drainer

**Class Rating:** PN 16

## UNA Special, Type 62

**Available Sizes:** 2½", 3" and 4"  
(DN 65, 80 and 100)



*Due to the large number of possible combinations please contact Flowserve Gestra for the recommended spare parts for your trap.*

### Capacity Charts

The charts show the maximum capacities for hot condensate. The capacities are a function of differential pressure or the difference between inlet and outlet pressures for the valve.

The orifice number refers to the maximum differential pressure (in bar) for which the UNA Special, Type 62 may be used as a liquid drainer. Each orifice has a different diameter and will provide a different capacity. Select the line that is most appropriate for the application without exceeding the maximum differential pressure.

The UNA Special, Type 62 is designed for liquids having a specific gravity of 1. Please consult Flowserve Gestra for fluids with different specific gravities.

### Body Pressure/Temperature Rating

The chart shows the maximum shell (body) pressure and temperature rating. Operating differential pressure is limited to **230 psi (16 bar)**.

### Material/Test Certificates

All inspection requirements must be stated at time of order. Test certificates can be issued on request in accordance with EN 10204 – 2.2 and -3.1B. Heat Codes from body and cover are required.

### Available End Connections

Flanges: ANSI 150RF

### How to Order

Specify trap, orifice, end connection size and type.

For Example: UNA Special, Type 62 Simplex 2" Orifice A08

# Gestra® Float Trap • Liquid Drainer

## UNA PN 25

**320**

psi  
Maximum Δp  
(22 bar)

**Class Rating:** PN 25

**Available Sizes:** 2" and 2½"  
(DN 50 and 65)

**Not intended for use as a steam trap.**

### Application

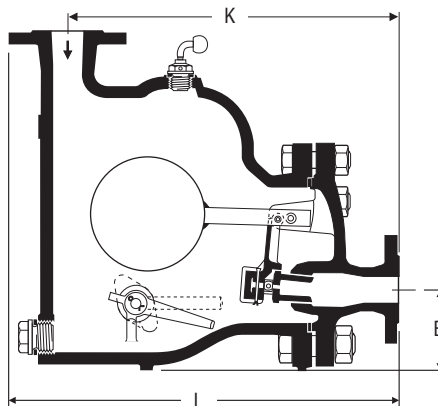
The UNA PN 25 float trap is used to drain water or fluids from steam systems, compressed air systems or gas lines.

### Features and Benefits

- Cast steel body.
- Stainless Steel and Alloy Steel Internals.
- Operation is unaffected by back pressure.
- Useful for heat transfer fluids.
- Drain plug (standard) can be removed and replaced with an AK 45 for automatic drainage during shutdowns.
- Provided with a hand vent valve (standard) for depressurizing the trap body prior to servicing.
- Maximum operating temperature 752°F (400°C)
- Available with different orifices for maximum differential pressures from **30 to 320 psi**.
- Two (2) year guarantee.

### Materials

- Body and Cover – A216 WCB (DIN GS-C 25)
- Fixing studs and Spacer sleeves – A193 B7 (DIN 1.7258)
- Seat – SAE 51420F (DIN 1.4034)
- Slide Valve – A182 F6 (DIN 1.4021)
- Ball float – A182 F304 (DIN 1.4301)



Pressure / Temperature Ratings					
Maximum Service Pressure	[psig]	<b>360</b>	<b>320</b>	<b>245</b>	<b>185</b>
	[barg]	25	22	17	13
Related Temperature	[°F]	<b>248</b>	<b>392</b>	<b>572</b>	<b>752</b>
	[°C]	120	200	300	400
Maximum Differential Pressure	<b>320 psig (22 barg)</b>				

Dimensions and Weights		End Connections	
		Flanged	
Nominal Sizes	[inch]	<b>2</b>	<b>2 1/2</b>
	[mm]	50	65
Dimensions	E [inch]	<b>3.9</b>	<b>4.1</b>
	[mm]	100	105
	K [inch]	<b>17.5</b>	<b>18.5</b>
	[mm]	445	470
	L [inch]	<b>20.7</b>	<b>22.2</b>
	[mm]	527	563
Approx. Weight	[lbs]	<b>150</b>	<b>181</b>
	[kg]	68	82

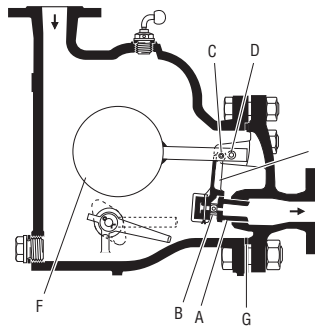
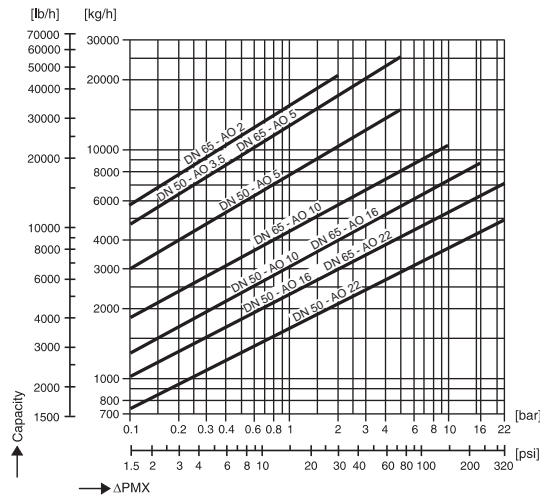
**320**  
psi  
Maximum  $\Delta p$   
(22 bar)

## Gestra® Float Trap • Liquid Drainer

**UNA PN 25**

**Class Rating:** PN 25

**Available Sizes:** 2" and 2½"  
(DN 50 and 65)



### Capacity Charts

The charts show the maximum capacities for hot condensate. The capacities are a function of differential pressure or the difference between inlet and outlet pressures for the valve.

The orifice number refers to the maximum differential pressure (in bar) for which the UNA PN 25 may be used as a liquid drainer. Each orifice has a different diameter and will provide a different capacity. Select the line that is most appropriate for the application without exceeding the maximum differential pressure.

The UNA PN 25 is designed for liquids having a specific gravity of 1. Please consult Flowserve Gestra for fluids with different specific gravities.

### Body Pressure/Temperature Rating

The chart shows the maximum shell (body) pressure and temperature rating. Operating differential pressure is limited to **320 psi (22 bar)**.

### Material/Test Certificates

All inspection requirements must be stated at time of order. Test certificates can be issued on request in accordance with EN 10204 – 2.2 and -3.1B. Heat Codes from body and cover are required.

### Available End Connections

Flanges: ANSI 150RF

### How to Order

Specify trap, orifice, end connection size and type.

For Example: UNA PN 25 2" Simplex Orifice A08

Standard Spare Parts			
Item Number	Description	UNA PN 25 2"	UNA PN 25 2 1/2"
A	Seat		
	Orifice 2	-	210311
	Orifice 3.5	210325	-
	Orifice 5	210324	210325
	Orifice 10	210336	210337
	Orifice 16	210351	210336
B	Slide Valve		
	Orifice 2	-	210355
	Orifice 3.5	210372	-
	Orifice 5	210371	210372
	Orifice 10	210383	210384
	Orifice 16	210395	210383
	Orifice 22	209547	210395
C	Bolt	210463	210463
D	Bolt	210277	210281
E	Slide valve rod		
	Simplex Duplex	200840 200858	200840 200858
F	Ball float	210452	210453
G	Cover gasket	210585	210586

# Gestra® Float Trap • Liquid Drainer

**UNA PN 25**

**320**  
psi  
Maximum Δp  
(22 bar)

**Class Rating:** PN 25

**Available Sizes:** 3" and 4"  
(DN 50 and 65)

**Not intended for use as a steam trap.**

**Application**

The UNA PN 25 float trap is used to drain water or fluids from steam systems, compressed air systems or gas lines.

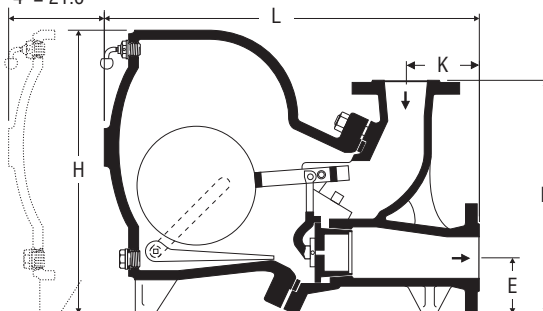
**Features and Benefits**

- Cast steel body.
- Stainless Steel and Alloy Steel Internals.
- Operation is unaffected by back pressure.
- Useful for heat transfer fluids.
- Drain plug (standard) can be removed and replaced with an AK 45 for automatic drainage during shutdowns.
- Provided with a hand vent valve (standard) for depressurizing the trap body prior to servicing.
- Maximum operating temperature 752°F (400°C)
- Available with different orifices for maximum differential pressures from **30 to 320 psi**.
- Two (2) year guarantee.

**Materials**

- Body and Cover – A216 WCB (DIN GS-C 25)
- Bolts – ASTM A194-2 (DIN 1.1191)
- Nuts – ASTM A194-1 (DIN 1.1181)
- Seat – SAE 51420F (DIN 1.4034)
- Slide Valve – A182 F6 (DIN 1.4021)
- Ball float – A182 F304 (DIN 1.4301)

Space required for opening trap:  
3" = 18.5"  
4" = 21.6"



Pressure / Temperature Ratings					
Maximum Service Pressure	[psig]	<b>360</b>	<b>320</b>	<b>245</b>	<b>185</b>
	[barg]	25	22	17	13
Related Temperature	[°F]	<b>248</b>	<b>392</b>	<b>572</b>	<b>752</b>
	[°C]	120	200	300	400
Maximum Differential Pressure	<b>320 psig (22 barg)</b>				

Dimensions and Weights		End Connections	
		Flanged	
Nominal Sizes	[inch]	<b>3</b>	<b>4</b>
	[mm]	80	100
Dimensions	B [inch]	<b>17.5</b>	<b>20.5</b>
	[mm]	445	520
	E [inch]	<b>4.3</b>	<b>4.7</b>
	[mm]	110	120
	H [inch]	<b>21.5</b>	<b>25.8</b>
	[mm]	545	655
K [inch]	<b>5.5</b>	<b>5.5</b>	
	[mm]	140	140
L [inch]	<b>29</b>	<b>34.4</b>	
	[mm]	740	875
Approx. Weight	[lbs]	<b>295</b>	<b>485</b>
	[kg]	134	220

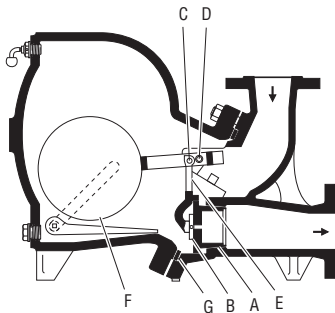
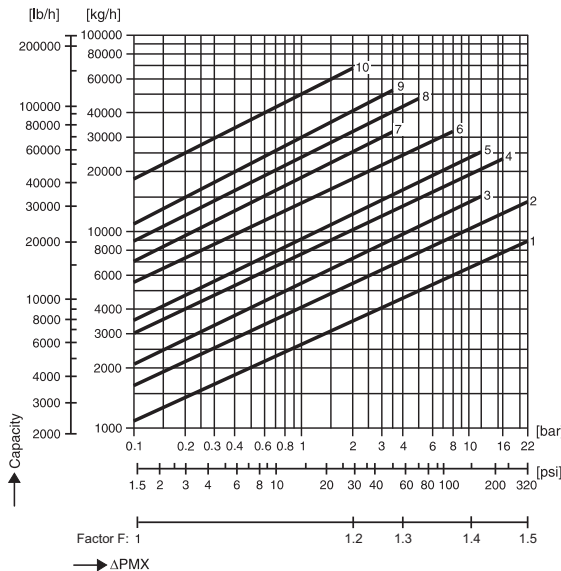
**320**  
psi  
Maximum  $\Delta p$   
(22 bar)

## Gestra® Float Trap • Liquid Drainer

**UNA PN 25**

**Class Rating:** PN 25

**Available Sizes:** 3" and 4"  
(DN 50 and 65)



Standard Spare Parts			
Item Number	Description	UNA PN 25 3"	UNA PN 25 4"
A	Seat		
	Orifice 2	221513	210314
	Orifice 3.5	221515	221525
	Orifice 5	221517	221527
	Orifice 8	209074	221531
	Orifice 12	209086	209087
	Orifice 16	209101	210353
B	Slide Valve		
	Orifice 2	221514	210361
	Orifice 3.5	221516	221526
	Orifice 5	221518	221528
	Orifice 8	208915	221532
	Orifice 12	208927	208931
	Orifice 16	208942	210397
C	Bolt	210465	210465
	Bolt	210477	210477
E	Slide valve rod	209281	221315
F	Ball float	209266	210283
G	Cover gasket	208966	210587

### Capacity Charts

The charts show the maximum capacities for hot condensate. The capacities are a function of differential pressure or the difference between inlet and outlet pressures for the valve.

The orifice number refers to the maximum differential pressure (in bar) for which the UNA PN 25 may be used as a liquid drainer. Each orifice has a different diameter and will provide a different capacity. Select the line that is most appropriate for the application without exceeding the maximum differential pressure.

The UNA PN 25 is designed for liquids having a specific gravity of 1. Please consult Flowserve Gestra for fluids with different specific gravities.

### Body Pressure/Temperature Rating

The chart shows the maximum shell (body) pressure and temperature rating. Operating differential pressure is limited to **320 psi (22 bar)**.

### Material/Test Certificates

All inspection requirements must be stated at time of order. Test certificates can be issued on request in accordance with EN 10204 – 2.2 and -3.1B. Heat Codes from body and cover are required.

### Available End Connections

Flanges: ANSI 150RF

### How to Order

Specify trap, orifice, end connection size and type.

For Example: UNA PN 25 3" Orifice A08

Available Orifices		
	Size	Orifice
1	DN 80 (3")	O 22
2	DN 80 (3")	O 16
	DN 100 (4")	O 12
3	DN 80 (3")	O 12
4	DN 100 (4")	O 16
5	DN 80 (3")	O 8
	DN 100 (4")	O 12
6	DN 80 (3")	O 5
	DN 100 (4")	O 8
7	DN 80 (3")	O 3.5
8	DN 100 (4")	O 5
9	DN 80 (3")	O 2
	DN 100 (4")	O 3.5
10	DN 100 (4")	O 2

# Gestra® Float Trap • Liquid Drainer

## UNA Special PN 63

**650**  
psi  
Maximum Δp  
(45 bar)

**Class Rating:** PN 63

**Available Sizes:** 2½", 3" and 4"  
(DN 65, 80 and 100)

**Not intended for use as a steam trap.**

### Application

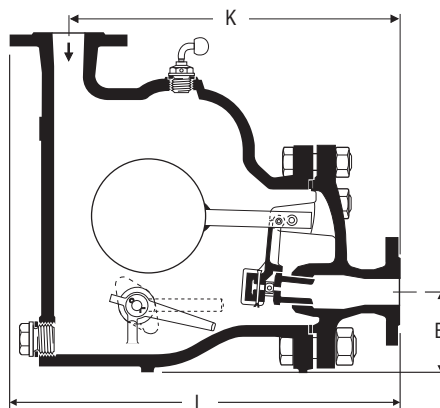
The UNA Special PN 63 float trap is used to drain water or fluids from steam systems, compressed air systems or gas lines.

### Features and Benefits

- Cast steel body.
- Stainless Steel and Alloy Steel Internals.
- Operation is unaffected by back pressure.
- Useful for heat transfer fluids.
- Provided with a hand vent valve (standard) for depressurizing the trap body prior to servicing.
- Maximum operating temperature 752°F (400°C)
- Available with different orifices for maximum differential pressures from **30 to 320 psi**.
- Two (2) year guarantee.

### Materials

- Body and Cover – ASTM A217 WC1 (DIN 1.5419)
- Fixing studs and Spacer sleeves – A193 B7 (DIN 1.7258)
- Seat – AISI 302 (DIN 1.43) with Hard Faced overlay
- Slide Valve – AISI-420 (DIN 1.4028) with Hard Faced overlay
- Ball float – ASTM 409 (DIN 1.4512)



Pressure / Temperature Ratings				
Maximum Service Pressure	[psig]	<b>914</b>	<b>812</b>	<b>653</b>
	[barg]	63	56	45
Related Temperature	[°F]	<b>482</b>	<b>572</b>	<b>842</b>
	[°C]	250	300	450
Maximum Differential Pressure	<b>650 psig (45 barg)</b>			

Dimensions and Weights		End Connection		
		Flanged		
Nominal Sizes	[inch]	<b>2 1/2</b>	<b>3</b>	<b>4</b>
	[mm]	65	80	100
Dimensions	E [inch]	<b>5.1</b>	<b>5.7</b>	<b>6.3</b>
	[mm]	130	145	160
	K [inch]	<b>22.2</b>	<b>27.2</b>	<b>27.6</b>
	[mm]	565	690	700
	L [inch]	<b>26.3</b>	<b>31.4</b>	<b>32.5</b>
	[mm]	668	798	825
Approx. Weight	[lbs]	<b>275</b>	<b>308</b>	<b>495</b>
	[kg]	125	140	225

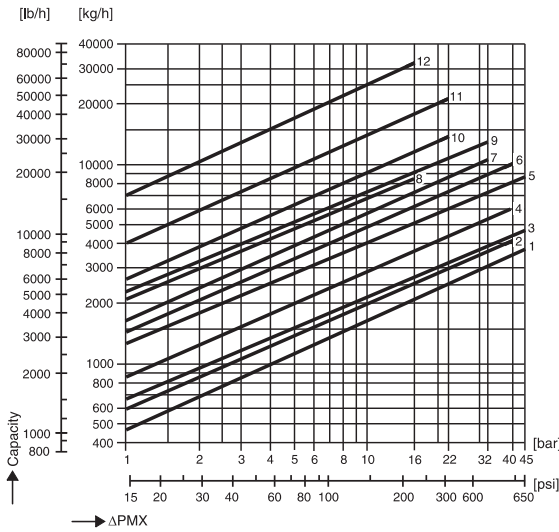
**650**  
psi  
Maximum  $\Delta p$   
(45 bar)

## Gestra® Float Trap • Liquid Drainer

**Class Rating:** PN 63

## UNA Special PN 63

**Available Sizes:** 2½", 3" and 4"  
(DN 65, 80 and 100)



### Capacity Charts

The charts show the maximum capacities for hot condensate. The capacities are a function of differential pressure or the difference between inlet and outlet pressures for the valve.

The orifice number refers to the maximum differential pressure (in bar) for which the UNA Special PN 63 may be used as a liquid drainer. Each orifice has a different diameter and will provide a different capacity. Select the line that is most appropriate for the application without exceeding the maximum differential pressure.

The UNA Special PN 63 is designed for liquids having a specific gravity of 1. Please consult Flowserve Gestra for fluids with different specific gravities.

### Body Pressure/Temperature Rating

The chart shows the maximum shell (body) pressure and temperature rating. Operating differential pressure is limited to **650 psi (45 bar)**.

### Material/Test Certificates

All inspection requirements must be stated at time of order. Test certificates can be issued on request in accordance with EN 10204 – 2.2 and -3.1B. Heat Codes from body and cover are required.

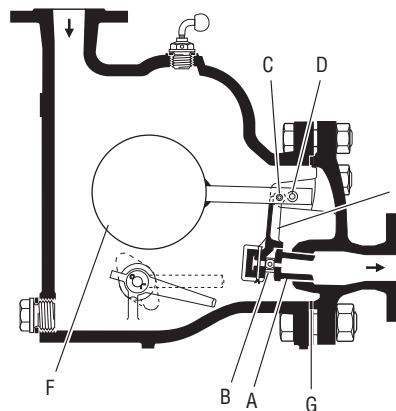
### Available End Connections

Flanges: ANSI 600RF

### How to Order

Specify trap, orifice, end connection size and type.

For Example: UNA Special PN 63 3" Orifice AO 22



*Due to the large number of possible combinations please contact Flowserve Gestra for the recommended spare parts for your trap.*

Available Orifices		
	Size	Orifice
1	DN 65 (2 1/2")	O 45
2	DN 65 (2 1/2")	O 40
3	DN 80 (3")	O 45
4	DN 65 (2 1/2")	O 32
	DN 80 (3")	O 40
5	DN 100 (4")	O 45
6	DN 65 (2 1/2")	O 22
	DN 100 (4")	O 40
7	DN 80 (3")	O 32
8	DN 65 (2 1/2")	O 16
9	DN 100 (4")	O 32
10	DN 80 (3")	O 22
11	DN 80 (3")	O 16
	DN 100 (4")	O 22
12	DN 100 (4")	O 16



# Gestra® Steam Trap • Thermodynamic Steam Trap

**DK 36/A7**

**420**  
psi  
Maximum Δp  
(29 bar)

**Class Rating:** ANSI 300

**Available Sizes:** 1/2", 3/4" and 1"  
(DN 15, 20 and 25)

**Application**

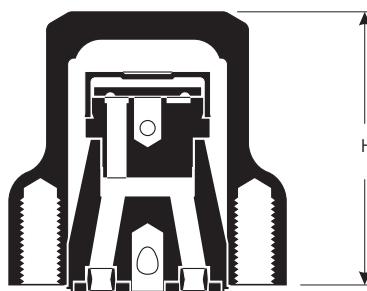
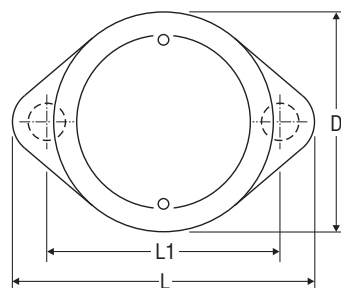
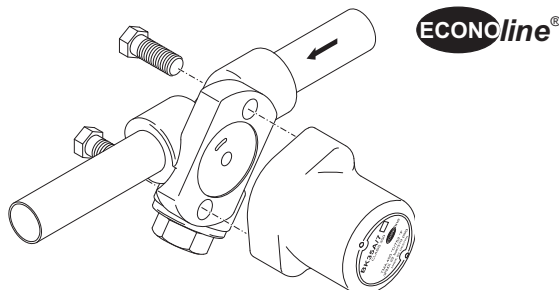
The ECONOline® DK 36/A7 steam trap is used for low capacity applications such as drip and tracing. The trap is attached to the universal connector by means of 2 hex head bolts and can be used on any existing connectors in your piping system.

**Features and Benefits**

- Cyclical discharge eases audible / visual performance checking.
- Resistant to water hammer.
- Encapsulated control unit eliminates the need for insulating covers when used in outside installations.
- Operates with up to 80% back pressure (based on absolute pressures).
- Horizontal orientation recommended for maximum performance.

**Materials**

- Cover – A351-CF8M (DIN 1.4408)
- Cover Bolts – ASTM A193-B7 (DIN 1.7225)
- Regulator Disc – Stainless Steel
- Other Internals – Stainless Steel
- Connector – A351-CF8M (DIN 1.4408)



Dimensions and Weights		End Connections		
		Screwed / Socket Weld		
Nominal Sizes	[inch] [mm]	1/2 15	3/4 20	1 25
Dimensions	D [inch] [mm]	1.9 49		
	L [inch] [mm]	2.6 66		
	L1 [inch] [mm]	2.0 51		
	H [inch] [mm]	2.6 65		
Approx. Weight w/o connector	[lbs] [kg]	1.5 0.7	1.8 0.8	2.2 1
	Approx. Weight with Connector	[lbs] [kg]	4.2 1.9	4.0 1.8

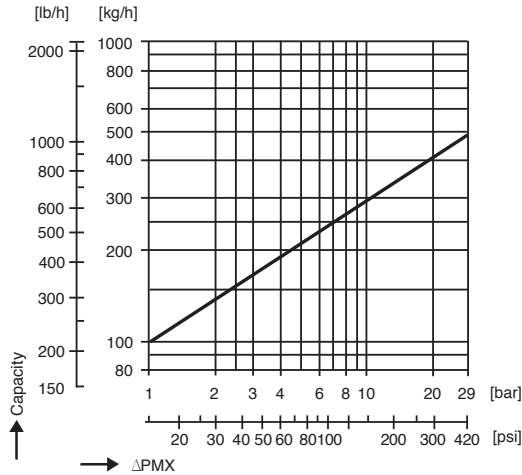
**420**  
psi  
Maximum  $\Delta p$   
(29 bar)

**Gestra® Steam Trap •  
Thermodynamic Steam Trap**

**DK 36/A7**

**Class Rating:** ANSI 300

**Available Sizes:** ½", ¾" and 1"  
(DN 15, 20 and 25)



**Capacity Charts**

The chart shows the maximum capacities for hot and cold condensate. The capacities are a function of differential pressure or the difference between inlet and outlet pressures for the trap.

The Curve shows the maximum capacity when discharging hot condensate. For example, at a differential pressure of **100 psi** the maximum hot capacity is approximately **500 lb/h**.

**Available End Connections**

Screwed sockets: NPT, BSP

Socket-weld

Butt weld

**How to Order**

For the trap only:

DK 36/A7

For the trap and connector:

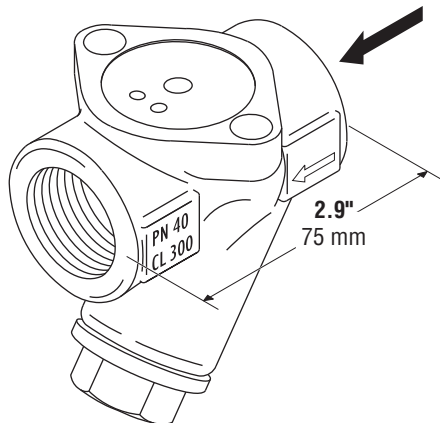
Specify trap, end connection size and type.

For Example: DK 36/A7 ½" NPT

Add "w/BOV" if blow-off valve is desired.

Pressure / Temperature Ratings						
Maximum Service Pressure	[psig]	719	613	519	458	421
	[barg]	49.6	42.3	35.8	31.6	29
Related Temperature	[°F]	68	212	392	572	842
	[°C]	20	100	200	300	450
Maximum Differential Pressure	320 psig (22 barg)					

Flowserve Gestra Universal Connector



# Gestra® Steam Trap • Thermodynamic Steam Trap

**DK 47**

**609**  
psi  
Maximum Δp  
(42 bar)

**Class Rating:** ANSI 600

**Available Sizes:** 3/8", 1/2", 3/4" and 1"  
(DN 10, 15, 20 and 25)

**Application**

The DK 47 steam trap is used for low capacity applications such as distribution line drips and tracers.

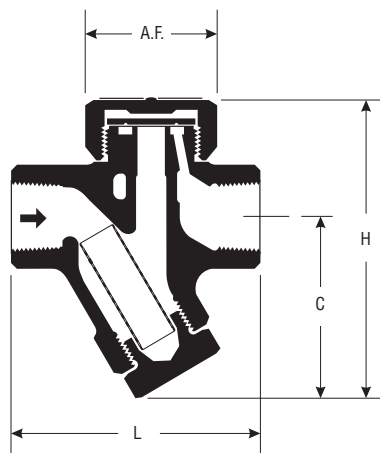
**Trap Types**

DK 47L: Trap is available in 3/8" to 1" body sizes. All body sizes have the same low condensate capacity.

DK 47H: Trap is available in 1/2" to 1" body sizes. The condensate capacity increases with the larger body size.

**Features and Benefits**

- Stainless steel body.
- End-to-end dimensions identical to most competitive models.
- Unaffected by water hammer or superheat – solid stainless steel internals.
- Operates with up to 80% back pressure (based on absolute pressures).
- Cyclical discharge eases audible / visual performance checking.
- Horizontal orientation suggested for maximum performance.
- Internal stainless steel strainer.



**Materials**

- Body – ASTM A743 CA40F (DIN 1.4027)
- Cap – AISI 420 (DIN 1.4021)
- Disc – AISI 420 (DIN 1.4021)
- Other Internals – Stainless Steel

Dimensions and Weights		End Connection			
		Screwed			
Nominal Sizes	[inch]	<b>3/8</b>	<b>1/2</b>	<b>3/4</b>	<b>1</b>
	[mm]	10	15	20	25
Dimensions	C [inch]	<b>2.5</b>	<b>2.5</b>	<b>2.7</b>	<b>2.8</b>
	[mm]	64	64	68	72
	L [inch]	<b>3.1</b>	<b>3.1</b>	<b>3.5</b>	<b>3.7</b>
	[mm]	78	78	90	95
	H [inch]	<b>4.1</b>	<b>4.1</b>	<b>4.4</b>	<b>4.9</b>
	[mm]	104	104	111	124
	A.F. [inch]	<b>4.1</b>	<b>1.6</b>	<b>1.6</b>	<b>2.2</b>
	[mm]	36	41	41	55
Approx. Weight	[lbs]	<b>1.7</b>	<b>1.7</b>	<b>2.2</b>	<b>3.5</b>
	[kg]	0.8	0.8	1.0	1.6

**609**

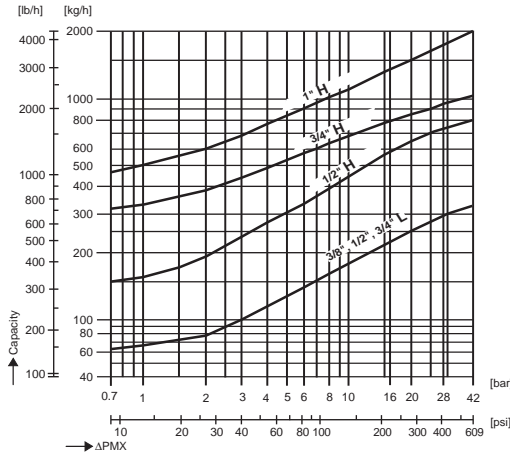
psi  
Maximum  $\Delta p$   
(42 bar)

**Gestra® Steam Trap •  
Thermodynamic Steam Trap**

**DK 47**

**Class Rating:** ANSI 600

**Available Sizes:** 3/8", 1/2", 3/4" and 1"  
(DN 10, 15, 20 and 25)



**Capacity Charts**

The capacity chart shows the maximum capacities for hot condensate. The capacities are a function of differential pressure or the difference between inlet and outlet pressures for the trap.

The set of curves show the capacity for each type of steam trap in the DK 47 series. The 'L' denotes low capacity, where traps with different end connection sizes all have the same low capacity. The 'H' denotes high capacity, where the trap capacity increases with increasing end connection size.

The curves show the maximum capacity when discharging hot or cold condensate.

For example, at a differential pressure of **100 psi**, the maximum hot capacity of the 1/2" DK 47 **H** is approximately **880 lb/h**.

**Material/Test Certificates**

All inspection requirements must be stated at time of order. Test certificates can be issued on request in accordance with EN 10204 – 2.2 and -3.1B. Body and Cap heat codes are required.

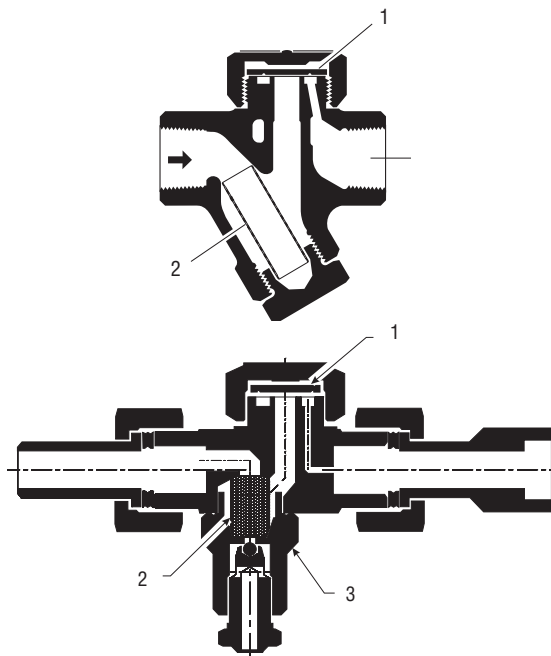
**Available End Connections**

Screwed sockets: NPT, BSP

**How to Order**

Specify trap and end connection size.

For Example: DK 47H 1/2" NPT



Standard Spare Parts			
Item Number	Description	Screwed	Butt-Weld Socket-Weld
1	Disc		
	3/8" - 1" L	372708	—
	1/2" H	372716	999716
	3/4" H	372724	999717
	1" H	372733	999718
2	Strainer	372710	999710
3	Blow-off Valve	—	999711

# Gestra® Steam Trap • Thermodynamic Steam Trap

**DK 57**

**609**  
psi  
Maximum Δp  
(42 bar)

**Class Rating:** ANSI 600

**Available Sizes:** 3/8", 1/2", 3/4" and 1"  
(DN 10, 15, 20 and 25)

**Application**

The DK 57 steam trap is used for low capacity applications such as distribution line drips and tracers.

**Trap Types**

DK 57L: Trap is available in 3/8" to 3/4" body sizes. All body sizes have the same low condensate capacity.

DK 57H: Trap is available in 1/2" to 1" body sizes. The condensate capacity increases with the larger body size.

**Features and Benefits**

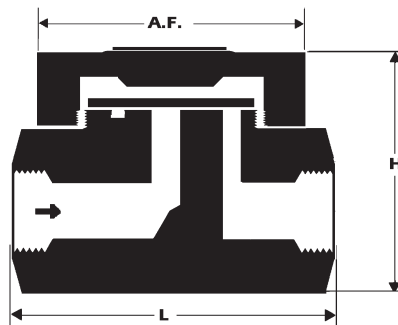
- Forged stainless steel body.
- End-to-end dimensions identical to most competitive models.
- Unaffected by water hammer – solid stainless steel internals.
- Operates with up to 80% back pressure (based on absolute pressures).
- Cyclical discharge eases audible/visual performance checking.
- Horizontal orientation suggested for maximum performance.
- Two (2) year guarantee.

**Materials**

- Body – AISI 420 F (DIN 1.4021)
- Cap – AISI 416 (DIN 1.4005)
- Disc – AISI 420 F (DIN 1.4021)

**Body Pressure/Temperature Rating**

The chart shows the maximum shell (body) pressure and temperature rating. Operating differential pressure is limited to **609 psi**.



Pressure / Temperature Ratings		
Maximum Operating Pressure	[psig]	609
	[barg]	42
Maximum Allowable Pressure	[psig]	914
	[barg]	63
Maximum Allowable Temperature	[°F]	752
	[°C]	400
Maximum admissible back pressure up to 80% of upstream pressure		

Dimensions and Weights		End Connection			
		Screwed			
Nominal Sizes	[inch]	<b>3/8</b>	<b>1/2</b>	<b>3/4</b>	<b>1</b>
	[mm]	10	15	20	25
Dimensions	L [inch]	<b>2.2</b>	<b>2.8</b>	<b>3.1</b>	<b>3.5</b>
		[mm]	55	70	80
	H [inch]	<b>1.9</b>	<b>2.0</b>	<b>2.5</b>	<b>2.9</b>
		[mm]	48	52	63
	A.F. [inch]	<b>1.4</b>	<b>1.6</b>	<b>1.6</b>	<b>2.2</b>
		[mm]	36	41	41
Approx. Weight	[lbs]	<b>1.0</b>	<b>1.3</b>	<b>2.0</b>	<b>3.1</b>
	[kg]	0.5	0.6	0.9	1.4

**609**

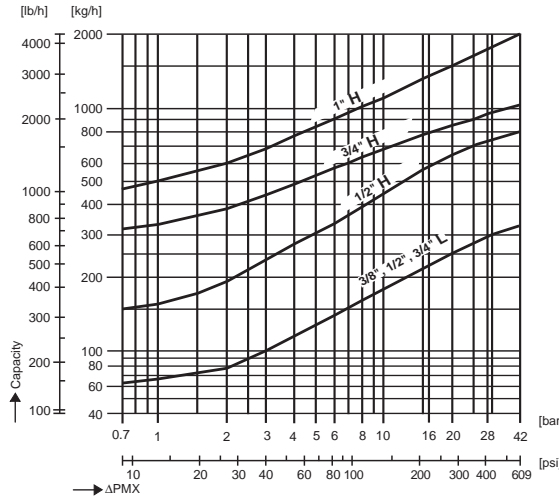
psi  
Maximum  $\Delta p$   
(42 bar)

**Gestra® Steam Trap •  
Thermodynamic Steam Trap**

**DK 57**

**Class Rating:** ANSI 600

**Available Sizes:** 3/8", 1/2", 3/4" and 1"  
(DN 10, 15, 20 and 25)

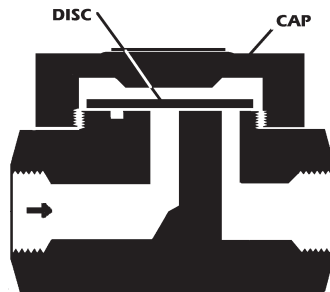


**Capacity Charts**

The capacity chart shows the maximum capacities for hot condensate. The capacities are a function of differential pressure or the difference between inlet and outlet pressures for the trap.

The set of curves show the capacity for each type of steam trap in the DK 57 series. The 'L' denotes low capacity, where traps with different end connection sizes all have the same low capacity. The 'H' denotes high capacity, where the trap capacity increases with increasing end connection size.

The curves show the maximum capacity when discharging hot condensate. For example, at a differential pressure of **100 psi**, the maximum hot capacity of the 1/2" DK 57 H is approximately **800 lbs/hr**.



**Material/Test Certificates**

All inspection requirements have to be stated at time of order. Test certificates can be issued on request in accordance with EN 10204 – 2.2 and -3.1B. Heat Codes from body and cap are required.

**Available End Connections**

NPT, BSP

**How to Order**

Specify trap and end connection size.

For Example: DK 57 H 1/2" NPT

Standard Spare Parts		
Item Number	Description	DK 57
1	Body	
2	Disc	
	3/8" - 3/4" L	372708
	1/2" H	372716
	3/4" H	372724
	1" H	372733
3	Bonnet	

# Gestra® Specialty Trap • Condensate Drain Valve

## AK 45

**Class Rating:** Class 300

**Available Sizes:** 1/2", 3/4" and 1"  
(DN 15, 20 and 25)

### Application

The RHOMBUSline® AK 45 is a pressure-activated drain valve that prevents freezing and waterhammer damage by automatically draining condensate from steam or condensate lines during startup and shutdown.

### Operation

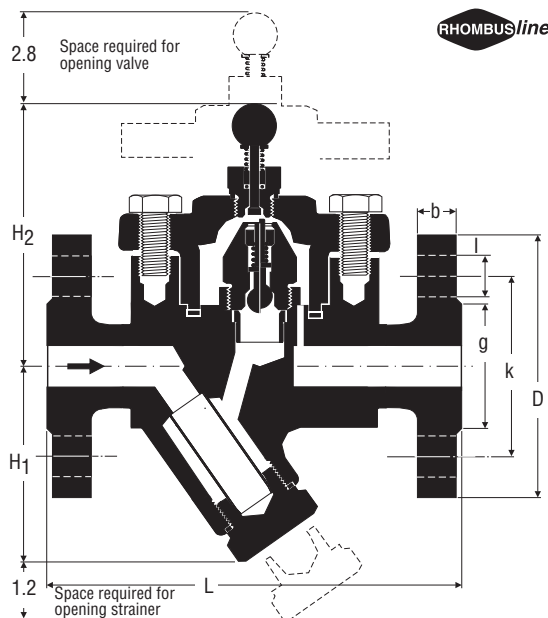
Spring pressure (preset at **12 psi**) holds the drain valve open until the service pressure exceeds this value, at which time the valve closes. The drain valve stays closed until the pressure is reduced to the preset value. Valve must be piped to atmospheric discharge.

### Features and Benefits

- Forged carbon steel body.
- Unaffected by water hammer – solid stainless steel internals.
- Hand Purging Knob standard.
- Two-bolt cover for easy in-line inspection and maintenance – no need to remove the valve from the piping to repair or replace the internals.
- Can be installed in any position.
- Mechanical stops prevent crushing of the gasket for long life – no gasket replacement required.
- Internal stainless steel Y-strainer with optional blowoff valve.
- Integral check valve design.
- Two (2) year guarantee.

### Materials

- Body and Cover – ASTM A105 (DIN 1.0460)
- Cover Bolts – ASTM A193B7 (DIN 1.7258)
- Other Internals – Stainless Steel



Dimensions and Weights		End Connections					
		Flanged			Screwed Socket-Weld		
Nominal Sizes	[inch] [mm]	1/2 15	3/4 20	1 25	1/2 15	3/4 20	1 25
Dimensions	L [inch] [mm]	5.9 150	5.9 150	6.3 160	3.7 95		
	H1 [inch] [mm]	2.8 70			2.8 70		
	H2 [inch] [mm]	3.8 97			3.8 97		
Approx. Weight	[lbs] [kg]	8.1 3.7	9.5 4.3	10.6 4.8	4.8 2.2	4.6 2.1	4.4 2

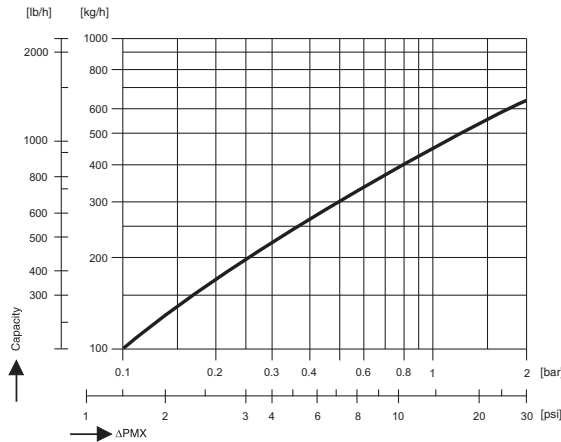
Flange Dimensions	End Connections								
	DIN			CL 150			CL 300		
D [inch] [mm]	3.7 95	4.1 105	4.5 115	3.5 88.9	3.9 98.4	4.2 107.9	3.7 95.2	4.6 117.5	4.9 123.8
b [inch] [mm]	0.6 16	0.7 18	0.7 18	0.4 11.1	0.5 12.7	0.6 14.3	0.6 14.3	0.6 15.9	0.7 17.5
k [inch] [mm]	2.6 65	3 75	3.3 85	2.4 60.3	2.7 69.8	3.1 79.4	2.6 66.7	3.2 82.5	3.5 88.9
g [inch] [mm]	1.8 45	2.3 58	2.7 68	1.4 34.9	1.7 42.9	2 50.8	1.4 34.9	1.7 42.9	2 50.8
l [inch] [mm]	0.6 14	0.6 14	0.6 14	0.6 15.9	0.6 15.9	0.6 15.9	0.6 15.9	0.7 19	0.7 19
Number of bolts	4	4	4	4	4	4	4	4	4

# Gestra® Specialty Trap • Condensate Drain Valve

## AK 45

**Class Rating:** Class 300

**Available Sizes:** ½", ¾" and 1"  
(DN 15, 20 and 25)



### Capacity Charts

The chart shows the maximum capacity for cold condensate. The capacities are a function of differential pressure or the difference between inlet and outlet pressures for the trap.

The curve shows the maximum capacity when discharging cold condensate at a temperature of **68°F (20°C)**. For example, at a differential pressure of **14.5 psi (1 bar)**, the maximum cold capacity is approximately **900 lb/hr**.

### Body Pressure/Temperature Rating

The chart shows the maximum shell (body) pressure and temperature rating. Operating differential pressure is limited to **320 psi**.

Pressure / Temperature Ratings				
Maximum Service Pressure	[psig]	465	320	305
	[barg]	32	22	21
Related Temperature	[°F]	482	725	842
	[°C]	250	385	400

### Material/Test Certificates

All inspection requirements must be stated at time of order. Test certificates can be issued on request in accordance with EN 10204 – 2.2 and -3.1B. Heat Codes from body and cover are required.

### Available End Connections

NPT, BSP

ANSI 150 RF, 300 RF

DIN PN 40

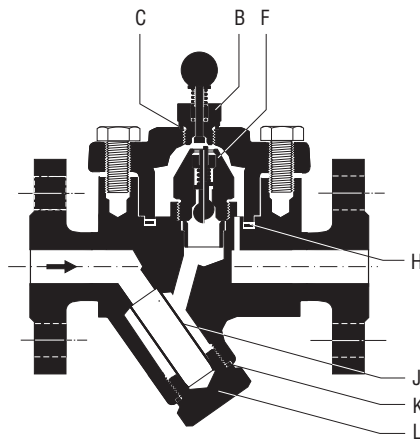
### How to Order

Specify trap, end connection size and type.

For Example: AK 45 ½" NPT

If ANSI flanged ends are required, please specify either ANSI 150 RF or ANSI 300 RF.

Please add "w/BOV" as a suffix if optional blowoff valve is desired.



Standard Spare Parts		
Item Number	Description	AK 45
B	Hand Purging Knob	375435
C	Gasket	375878I
F	Valve Insert	375434
H	Cover Gasket	375159I
J, K, L	Complete Strainer Set	375113
K	Strainer Plug Gasket	375162I



# Gestra® Steam Trap • Thermostatic Steam Trap

## SMK 22

**87**  
psi  
Maximum Δp  
(6 bar)

**Class Rating:** PN 10

**Available Sizes:** 1/2", 3/4" and 1"  
(DN 15, 20 and 25)

### Application

The SMK 22 steam trap is designed for modulating discharge of condensate in aseptic or sanitary applications. Offered in either clamped or welded end connections with clamped body halves or bolted to meet the customer's needs.

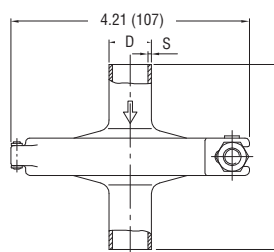
### Features and Benefits

- Control capsule of Hastelloy® and Stainless Steel for superior corrosion resistance.
- Self centering valve cone to ensure steam-tight shut-off. Unaffected by particulate matter.
- All Stainless Steel construction for corrosion resistance.
- Body seal is made of EPDM in accordance with FDA regulations.
- Discharges hot condensate at approximately **18°F** (10°C) below saturation temperature throughout its operating range.
- One internal regulator for all pressure ranges.
- Resistant to water hammer.
- All wetted surfaces have a surface finish of less than 0.8 μm.
- Automatically vents air and non-condensable gases and has a high cold water capacity for rapid start-up.
- Operates with zero steam loss throughout its operating range saving steam and money during the life of the trap.
- Can be installed in any position.
- Three (3) year guarantee.

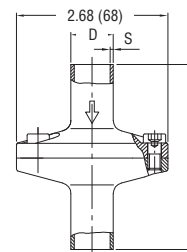
### Materials

- Body – ASTM A182 F304 (DIN 1.4301)
- Regulator – Hastelloy® and 316 SST
- Body Gasket – FDA approved EPDM.
- Other Components – Stainless Steel

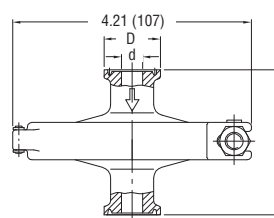
SMK 22A



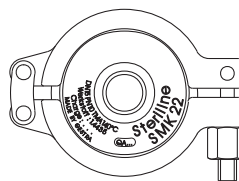
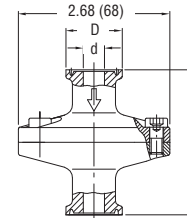
SMK 22B



SMK 22C



SMK 22D



Dimensions and Weights		End Connections					
		Butt-Weld			Tri-Clamp		
Nominal Sizes	[inch]	1/2	3/4	1	1/2	3/4	1
	[mm]	15	20	25	15	20	25
Dimensions	L [inch]	3.3			3.3		
	[mm]	83			83		
	D [inch]	0.5	0.8	1.0	1.0	1.0	2.0
	[mm]	12.7	19.05	25.4	25.3	25.3	50.5
	d [inch]	—			0.4	0.6	0.9
[mm]	—			9.5	15.9	22.2	
S [inch]	0.06			—			
[mm]	1.65			—			
Approx. Weight	[lbs]	1.3	1.5	2.0	1.3	1.5	2.0
	[kg]	0.6	0.7	0.9	0.6	0.7	0.9

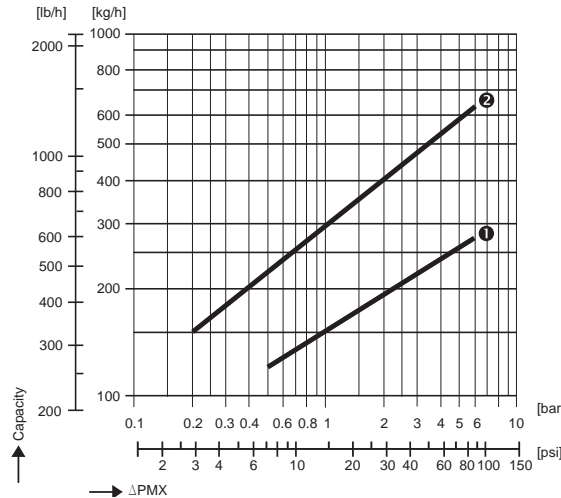
**87**  
psi  
Maximum  $\Delta p$   
(6 bar)

## Gestra® Steam Trap • Thermostatic Steam Trap

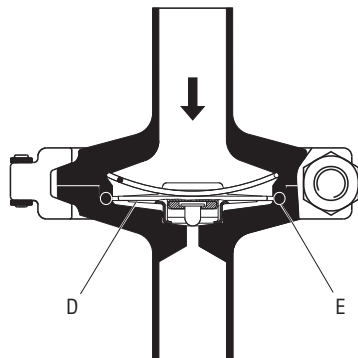
**SMK 22**

**Class Rating:** PN 10

**Available Sizes:** ½", ¾" and 1"  
(DN 15, 20 and 25)



Pressure / Temperature Ratings		
Maximum Service Pressure	[psig]	145
	[barg]	10
Related Temperature	[°F]	302
	[°C]	150
Maximum Differential Pressure		87 psig (6 barg)



Standard Spare Parts		
Item Number	Description	SMK 22
D	Regulator (Steri Design)	375862
E	Body Gasket (made of EPDM in accordance with FDA regulations)	375673

### Capacity Charts

The chart shows the maximum capacities for hot and cold condensate. The capacities are a function of differential pressure or the difference between inlet and outlet pressures for the trap.

Curve 1 shows the maximum capacity when discharging hot condensate that is **18°F (10°C)** below steam saturation temperature. For example, at a differential pressure of **50 psi (3.4 bar)**, the maximum hot capacity is approximately **500 lb/h**.

Curve 2 shows the maximum capacity when discharging cold condensate at a temperature of **68°F (20°C)**. For example, at a differential pressure of **50 psi (3.4 bar)**, the maximum cold capacity is approximately **1,100 lb/h**.

### Body Pressure/Temperature Rating

The chart shows the maximum shell (body) pressure and temperature rating. Operating differential pressure is limited to **87 psi**.

### Material/Test Certificates

All inspection requirements must be stated at time of order. Test certificates can be issued on request in accordance with EN 10204 – 2.2 and -3.1B. Heat Codes from body halves are required.

### Available End Connections

Orbital BW

Tri-clamp

### How to Order

Specify trap and end connection size.

For Example: SMK 22C ½"

# Gestra® Steam Trap • Thermodynamic Steam Trap

**GK 11/21**

**85**  
psi  
Maximum Δp  
(6 bar)

**Class Rating:** PN 16

**Available Sizes:** 2", 2½", 3", 4" and 6"  
(DN 50, 65, 80, 100 and 150)

**Application**

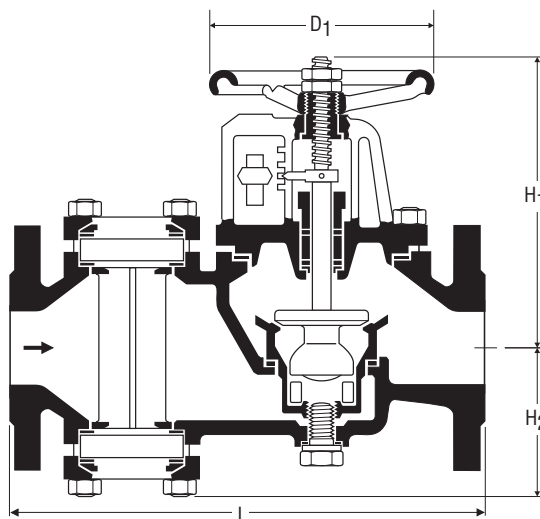
The GK 11/21 thermodynamic steam trap is used to drain large condensate flowrates from steam systems. The GK 11/21 utilizes the Flowserve Gestra stage nozzle for quiet operation with the ability to be continuously adjusted.

**Features and Benefits**

- Cast iron body.
- Cast Iron and Stainless Steel Internals.
- Operation is unaffected by back pressure.
- Integral Vaposcope for optimum trap adjustment.
- Can be continually adjusted between steam-tight and purge positions.
- Maximum flowrate of 1,000,000 lb/h.
- Easy in-line inspection and maintenance – no need to remove the trap from the piping to replace the internals.
- Maximum operating temperature 572°F (300°C)
- Two (2) year guarantee.

**Materials**

- Body and Cover – DIN material equivalent to ASTM – A126 Cl. B.
- Fixing studs and Spacer sleeves – DIN material equivalent to ASTM-A194-1
- Seat – 2"-3" DIN Material equivalent to A536  
4"-6" DIN Material equivalent to A126 Cl. B.
- Stage Nozzle – DIN Material equivalent to ASTM A126 Cl. B.
- Spindle – DIN Material equivalent to AISI 420.



Pressure / Temperature Ratings			
Maximum Service Pressure	[psig]	<b>230</b>	<b>185</b>
	[barg]	16	13
Related Temperature	[°F]	<b>248</b>	<b>572</b>
	[°C]	120	300
Maximum Differential Pressure		<b>85 psig (6 barg)</b>	

Dimensions and Weights		Trap Type				
		GK 21	GK 11			
Nominal Sizes	[inch]	<b>2</b>	<b>2 1/2</b>	<b>3</b>	<b>4</b>	<b>6</b>
	[mm]	50	65	80	100	150
Dimensions	L [inch]	<b>12.6</b>	<b>16.5</b>	<b>16.5</b>	<b>24.4</b>	<b>35.4</b>
	[mm]	320	420	420	620	900
	H1 [inch]	<b>8.7</b>	<b>10.8</b>	<b>10.8</b>	<b>19.1</b>	<b>26.4</b>
	[mm]	220	275	275	485	670
	H2 [inch]	<b>3.9</b>	<b>4.7</b>	<b>4.7</b>	<b>7.9</b>	<b>11.2</b>
[mm]	100	120	120	200	285	
D1	[inch]	<b>5.9</b>	<b>7.9</b>	<b>7.9</b>	<b>12.6</b>	<b>13.8</b>
	[mm]	150	200	200	320	350
Approx. Weight	[lbs]	<b>51</b>	<b>97</b>	<b>100</b>	<b>297</b>	<b>647</b>
	[kg]	23	44	45.3	135	294

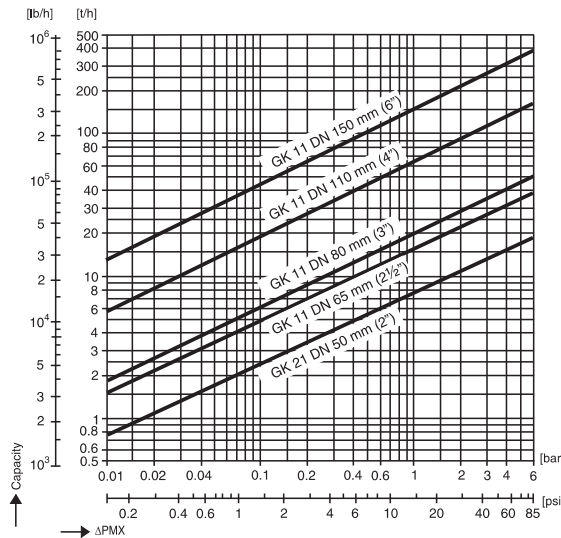
**85**  
psi  
Maximum  $\Delta p$   
(6 bar)

## Gestra® Steam Trap • Thermodynamic Steam Trap

**GK 11/21**

**Class Rating:** PN 16

**Available Sizes:** 2", 2½", 3", 4" and 6"  
(DN 50, 65, 80, 100 and 150)



### Capacity Charts

The charts show the maximum capacities for hot condensate with the trap three quarters open. The maximum capacity when the trap is in the purge position is approximately 15% higher. The capacities are a function of differential pressure or the difference between inlet and outlet pressures for the valve.

The cold water capacity of the GK traps is approximately 70% higher than the hot water capacity. When operating under a vacuum, the maximum capacity of the trap is reduced by approximately 35%.

### Body Pressure/Temperature Rating

The chart shows the maximum shell (body) pressure and temperature rating. Operating differential pressure is limited to **85 psi (6 bar)**.

### Material/Test Certificates

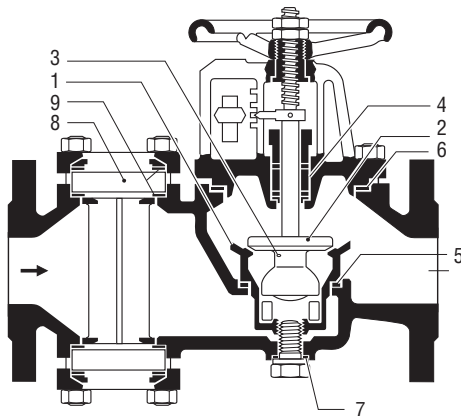
All inspection requirements must be stated at time of order. Test certificates can be issued on request in accordance with EN 10204 – 2.2 and -3.1B. Heat Codes from body and cover are required.

### Available End Connections

Flanges: ANSI 150RF

### How to Order

Specify trap and end connection size.  
For Example: GK 11/21 4" ANSI 150RF.



Spare Parts		Trap Type				
		GK 21	GK 11			
Number	Description	2 50	2 1/2 65	3 80	4 100	6 150
1	Nozzle Insert	094949	094960	094960	094983	080016
2	Stage Nozzle	094951	094969	094969	080000	080029
3	Headless Set screw	011286	011043	011043	011298	011310 2 pcs Required
4	Gland Packing	094549	094549	094549	080012	080036
5	Nozzle-insert gasket	094927	011296	011296	094999	011307
6	Cover gasket	071708	011297	011297	011302	011308
7	Plug gasket	071383	071383	071383	011303	000593
8	Glass	071717	011278	011278	071705	071705
9	Class Gasket	071715	043435	043465	094988	094988

# Gestra® Steam Trap • Thermostatic Steam Trap

**UBK 46**

**320**  
psi  
Maximum Δp  
(22 bar)

**Class Rating:** ANSI 300

**Available Sizes:** 1/2", 3/4" and 1"  
(DN 8, 10, 15 and 20)

**Application**

The UBK 46 steam trap is used for low capacity applications such as drips and tracers, and is designed for extensive subcooling of the condensate prior to release to reduce visible flashing.

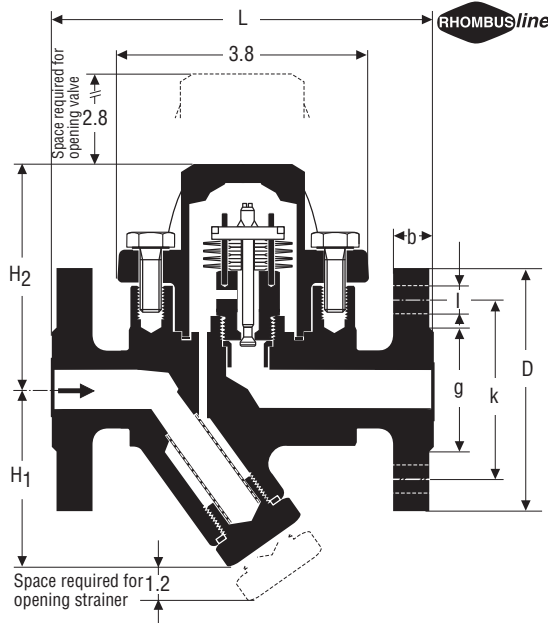
The stainless steel bimetallic plates and the staged nozzle assure long lasting service and zero steam loss operation even under superheat or water hammer conditions.

**Features and Benefits**

- Forged carbon steel body.
- Pressure assisted fail open design.
- Bimetallic regulator with fatigue-free stainless steel plates.
- Adjustable condensate discharge temperature.
- Unaffected by water hammer or superheat.
- Self draining – will not freeze when installed in gravity drainage position.
- Automatically vents air and non-condensable gases and has a high cold water capacity for rapid start-up.
- Operates with zero steam loss throughout its operating range saving steam and money during the life of the trap.
- Easy in-line inspection and maintenance – no need to remove the trap from the piping to replace the internals.
- Can be installed in any position.
- Integral stainless steel strainer.
- Internal check valve design.
- Two (2) year guarantee.

**Materials**

- Body and Cover – ASTM A105 (DIN 1.0460)
- Cover Bolts – ASTM A193 B7 (DIN 1.7258)
- Bimetallic Regulator – Stainless Steels
- Other Internals – Stainless Steel



Dimensions and Weights		End Connections								
		Flanged			Screwed Socket-Weld			Butt-Weld		
Nominal Sizes	[inch] [mm]	1/2 15	3/4 20	1 25	1/2 15	3/4 20	1 25	1/2 15	3/4 20	1 25
Dimensions	L [inch] [mm]	5.9 150	5.9 150	6.3 160	3.7 95			7.9 200		
	H1 [inch] [mm]	2.8 70			2.8 70			2.8 70		
	H2 [inch] [mm]	2.4 62			2.4 62			2.4 62		
Approx. Weight	[lbs]	8.1	9.5	10.6	4.8	4.6	4.4	5.5	5.5	5.5
	[kg]	3.7	4.3	4.8	2.2	2.1	2	2.5	2.5	2.5

Flange Dimensions		End Connections								
		DIN			CL 150			CL 300		
D [inch] [mm]	3.7 95	4.1 105	4.5 115	3.5 88.9	3.9 98.4	4.2 107.9	3.7 95.2	4.6 117.5	4.9 123.8	
b [inch] [mm]	0.6 16	0.7 18	0.7 18	0.4 11.1	0.5 12.7	0.6 14.3	0.6 14.3	0.6 15.9	0.7 17.5	
k [inch] [mm]	2.6 65	3 75	3.3 85	2.4 60.3	2.7 69.8	3.1 79.4	2.6 66.7	3.2 82.5	3.5 88.9	
g [inch] [mm]	1.8 45	2.3 58	2.7 68	1.4 34.9	1.7 42.9	2 50.8	1.4 34.9	1.7 42.9	2 50.8	
l [inch] [mm]	0.6 14	0.6 14	0.6 14	0.6 15.9	0.6 15.9	0.6 15.9	0.6 15.9	0.7 19	0.7 19	
Number of bolts	4	4	4	4	4	4	4	4	4	

**320**  
psi  
Maximum  $\Delta p$   
(22 bar)

## Gestra® Steam Trap • Thermostatic Steam Trap

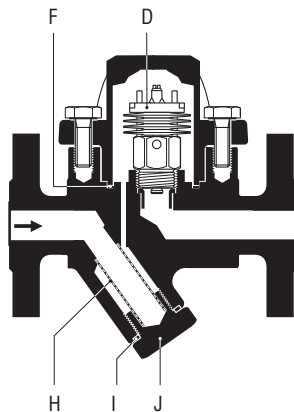
**UBK 46**

**Class Rating:** ANSI 300

**Available Sizes:** ½", ¾" and 1"  
(DN 8, 10, 15 and 20)

Maximum Service Pressure	[psig]	14.5	29	58	116	174	232	290	377	464
	[barg]	1	2	4	8	12	16	20	26	32
Opening Temperature (Factory Setting)	[F]	162	165	172	185	192	199	206	217	228
	[C]	72	74	78	85	89	93	97	103	109
Capacity at $\Delta t$ 10K below opening temperature	[lbs/hr]	206	249	299	361	405	436	464	497	526
	[kg/hr]	94	113	136	164	184	198	211	226	239
Cold condensate capacity at 68°F (start-up capacity)	[lbs/hr]	587	858	1,254	1,830	2,286	2,673	3,020	3,463	3,903
	[kg/hr]	267	390	570	832	1,039	1,215	1,373	1,574	1,774

Pressure / Temperature Ratings				
Maximum Service Pressure	[psig]	465	320	305
	[barg]	32	22	21
Related Temperature	[°F]	482	725	842
	[°C]	250	385	400
Maximum Differential Pressure	320 psig (22 barg)			



Standard Spare Parts		
Item Number	Description	UBK 46
D, F	Complete Regulator including cover gasket	375324
F	Cover Gasket	375159I
H, I, J	Complete Strainer set	375113
I	Strainer Gasket	375162I

### Capacity Charts

The capacity chart shows the capacities for hot and cold condensate. The capacities are a function of differential pressure or the difference between inlet and outlet pressures for the trap. The capacities indicated in the chart assume the factory setting and discharge to atmosphere.

### Body Pressure/Temperature Rating

The chart shows the maximum shell (body) pressure and temperature rating. Operating differential pressure is limited to **320 psi**.

### Material/Test Certificates

All inspection requirements must be stated at time of order. Test certificates can be issued on request in accordance with EN 10204 – 2.2 and -3.1B.

### Available End Connections

NPT, BSP

ANSI 150, 300

DIN PN 40

SW, BW

### How to Order

For Example: UBK 46 ½" NPT

If ANSI flanged ends are required, please specify either ANSI 150 RF or ANSI 300 RF.

**NOTE:** Special precautions must be taken with subcooled condensate when either discharging to atmosphere in cold climates or to your condensate return lines. Please consult your local Flowserve Gestra representative prior to installation.

***Check Valves***



---

This page intentionally left blank.



# Gestra® Check Valves • Threaded End Guided Disc Check Valve

**MB 26a**

600

psi  
Maximum Δp  
(40 bar)

**Available Sizes:** ½" to 2"  
(DN 15 to 50)

### Application

The MB 26a is used for preventing back flow in liquid and gas lines. Often used in hot water systems and as vacuum breakers on tanks and heat exchangers.

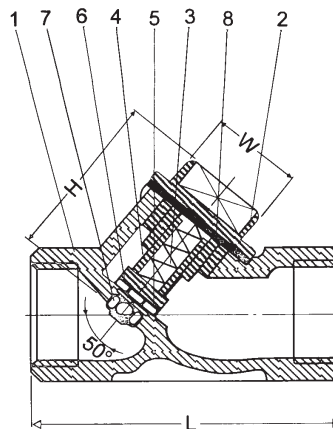
Stainless Steel Body with Stainless Steel internals in sizes from ½" to 2" with NPT threaded connections.

### Features and Benefits

- Spring assisted closure for rapid shut off and positive shutoff.
- Low pressure drop.
- Teflon seats provide bubble-tight shut off.
- Can be installed in any position.
- Rugged industrial design.

### Materials

- Body – Stainless Steel (ASTM A351 CF8M)
- Cap – Stainless Steel (ASTM A351 CF8M)
- Spring – AISI 304
- Disc – AISI 316
- Seat – (PTFE)
- Washer – AISI 304
- Nut – AISI 304
- Joint Gasket – PTFE



Pressure / Temperature Ratings				
Body Style	MB 26A			
Nominal Size	[inch]	1/2 - 2		
	[mm]	15 - 50		
Maximum Service Pressure	[psig]	570	380	110
	[barg]	39	26	7.5
Related Temperature	[°F]	100	300	400
	[°C]	38	149	204
Minimum Temperature	-20°F (-29°C)			

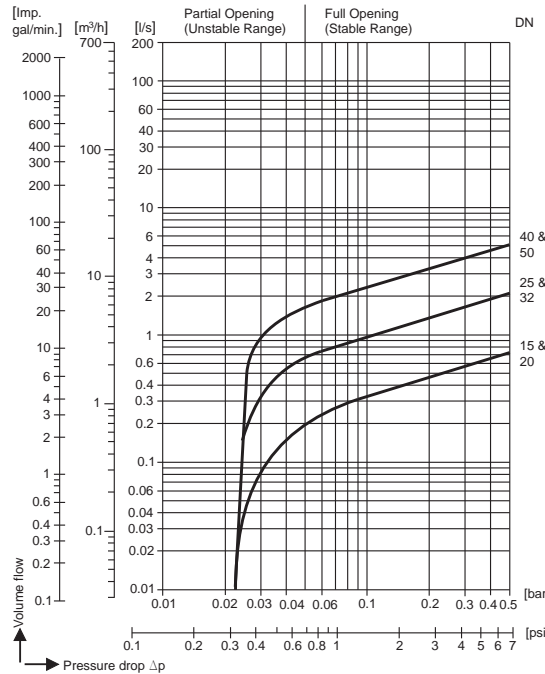
Dimensions and Weights		End Connections						
		NPT						
Nominal Sizes	[inch]	1/2	3/4	1	1 1/4	1 1/2	2	
	[mm]	15	20	25	32	40	50	
Dimensions	L	[inch]	2.56	2.95	3.54	4.33	4.72	5.91
		[mm]	65	75	90	110	120	150
	H	[inch]	1.57	1.97	2.44	2.76	3.34	3.91
		[mm]	40	50	62	70	85	99
	W	[inch]	1.06	1.34	1.57	1.97	2.24	3.5
		[mm]	27	34	40	50	57	89
Approx. Weight	[lbs]	0.5	0.9	1.6	2.5	4	6.5	
	[kg]	0.2	0.4	0.7	1.1	1.8	3.0	

**600**  
psi  
Maximum  $\Delta p$   
(40 bar)

**Gestra® Check Valves •**  
**Threaded End Guided Disc Check Valve**

**MB 26a**

**Available Sizes:** 1/2" to 2"  
(DN 15 to 50)



**Capacity Charts**

Check valve sizing is a function of the flow through the valve and the associated pressure drop. Check valves must be sized according to the application conditions and not simply matched to the existing pipe size.

It is important to avoid oversizing the check valve, which can lead to chatter and premature failure. Chatter is the rapid opening and closing of the valve, caused when sufficient opening pressure cannot be sustained upstream of the valve.

The curves on the right show the flow rate of the check valve in GPM of water at 68°F (20°C) as a function of the pressure drop through the valve.

It is imperative that the intersection point of the flow rate and the pressure drop is on the straight portion of the curve.

If the intersection falls on the curved portion, chattering will likely occur and a different valve must be chosen.

**Body Pressure/Temperature Rating**

The chart shows the maximum shell (body) pressure and temperature rating. Operating differential pressure is limited to the maximum service pressure shown in the chart.

**Spring Materials**

Special applications may require different spring material and/or tensions. If special springs are required, please consult your local Flowserve Gestra representative.

**How to Order**

Specify valve type and size.

The MB 26A series is only available with NPT ends.

For Example: MB 26A 2"

Nominal Sizes		Opening Pressures					
		[inch]	1/2	3/4	1	1 1/4	1 1/2
	[mm]	15	20	25	32	40	50
	[psi]	0.23	0.23	0.3	0.35	0.38	0.41
	[mbar]	16	16	21	24	26	28

# Gestra® Check Valves • Wafer Style Guided Disc Check Valve

## RK 70 and RK 71

Fits  
**ANSI 125**  
**ANSI 150**

Available Sizes: ½" to 8"  
(DN 15 to 200)

### Application

The RK 70 and RK 71 are used for preventing back flow in liquid and gas lines. Often used in hot water systems. Not to be used in steam service or pulsating flow.

### Valve Types

**RK 70:** Brass body with stainless steel spring and plastic valve disc for sizes from ½" to 4". Cast iron body with stainless steel spring and polyamide valve cone and spindle for sizes from 5" to 8". The RK 70 is used where silent operation is required, usually in hot water service.

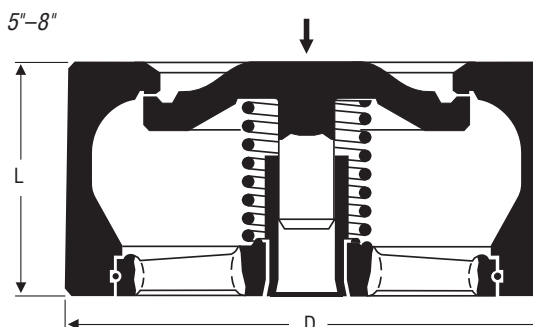
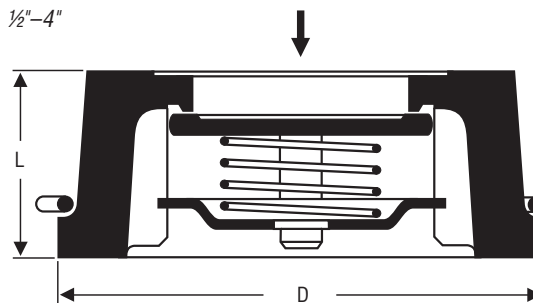
**RK 71:** Brass body and stainless steel internals for sizes from ½" to 4".

### Features and Benefits

- Wafer style, for easy installation between two ANSI flanges.
- Short overall length, less than 5½" for an 8" valve.
- Lightweight and of rugged construction.
- Metal-to-Metal seats are lapped to minimize leakage (RK 71 only).
- Can be installed in any position.
- For ½" to 4" check, the valve disc is guided by four ribs to ensure smooth operation with no binding. For sizes 5" and 8", the disc uses a center post inside a sleeve as a guide.

### Materials

- RK 70 (½"-4")
  - Body – Brass
  - Disc – Plastic
  - Spring – A313 Type 316
  - Spring Retainer – A182 Type 316
- RK 70 (5"-8")
  - Body – Cast Iron A126 Class A
  - Disc – Cast Iron A126 Class B
  - Spring – A313 Type 316
  - Spring Retainer – Cast Iron A126 Class B
- RK 71 (½"-4")
  - Body – Brass
  - Disc – A182 Type 316
  - Spring – A313 Type 316
  - Spring Retainer – A182 Type 316



Pressure / Temperature Ratings										
Body Style	RK 70			RK 70			RK 71			
Nominal Size	[inch]	1/2 - 4			5 - 8			1/2 - 4		
	[mm]	15 - 100			125 - 200			15 - 100		
Maximum Service Pressure	[psig]	85	43	29	21	14.5	7	230	200	185
	[barg]	6	3	2	1.5	1	.5	16	14	13
Related Temperature	[°F]	68	122	176	212	230	266	248	392	482
	[°C]	20	50	80	100	110	130	120	200	250
Minimum Temperature		-22°F (-30°C)			14°F (-10°C)			-76°F (-60°C)		

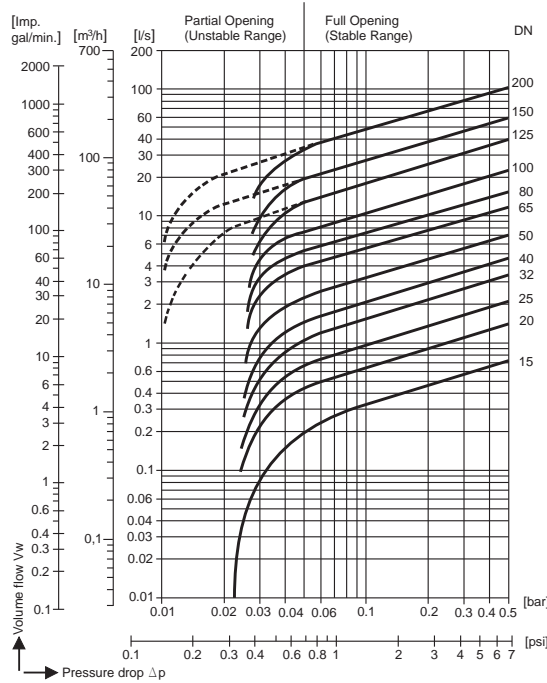
Dimensions and Weights													
Nominal Sizes	[inch]	1/2	3/4	1	1 1/4	1 1/2	2	2 1/2	3	4	5	6	8
	[mm]	15	20	25	32	40	50	65	80	100	125	150	200
Dimensions	D [inch]	1.6	1.9	2.2	2.8	3.2	3.7	4.5	5.2	6.0	7.2	8.2	10.4
	[mm]	40	47	56	72	82	95	115	132	152	184	209	264
L	[inch]	0.6	0.7	0.9	1.1	1.2	1.6	1.8	2	2.4	3.5	4.2	5.5
	[mm]	16	19	22	28	31.5	40	46	50	60	90	106	140
Approx. Weight	[lbs]	0.2	0.3	0.5	1.1	1.4	2.3	3.2	4.4	7.0	12.3	18.5	37.4
	[kg]	0.09	0.13	0.21	0.48	0.63	1.05	1.45	2	3.2	5.6	8.4	17

Fits  
ANSI 125  
ANSI 150

# Gestra® Check Valves • Wafer Style Guided Disc Check Valve

## RK 70 and RK 71

Available Sizes: 1/2" to 8"  
(DN 15 to 200)



### Pressure Drop Chart

The curves given in the chart are valid for water at 68°F (20°C). To read the pressure drop for other fluids the equivalent water volume flowrate must be calculated and used in the graph.

The values indicated in the chart are applicable to spring-assisted valves with horizontal flow. With vertical flow, insignificant deviations occur only within the range of partial opening.

### Body Pressure/Temperature Rating

The chart shows the maximum shell (body) pressure and temperature rating. Operating differential pressure is limited to the maximum service pressure shown in the chart.

### Material/Test Certificates

The following test certificates can be issued on request in accordance with EN 10204 – 2.2 and -3.1B. All inspection requirements have to be stated with the order. Test and/or Inspection certificates must be requested at time of order and cannot be issued after the equipment has been shipped from the factory.

### Available End Connections

Fits between: ANSI 125  
ANSI 150

### How to Order

Specify valve type and size.

For Example: RK 70 2"

If special springs are required please consult Flowserve Gestra.

Valve Type	Size		Opening Pressures							
			Without Springs RK 70 Only		With Standard Springs					
	[Inch]	[mm]	[psi]	[mbar]	[psi]	[mbar]	[psi]	[mbar]	[psi]	[mbar]
RK 70 RK 71	1/2	15	<.01	.4	0.33	22.8	0.32	22.4	0.32	22.0
RK 70 RK 71	3/4	20	<.01	.4	0.33	22.8	0.32	22.4	0.32	22.0
RK 70 RK 71	1	25	<.01	.4	0.33	22.8	0.32	22.4	0.32	22.0
RK 70 RK 71	1 1/4	32	<.01	.5	0.35	24.0	0.34	23.5	0.33	23.0
RK 70 RK 71	1 1/2	40	<.01	.5	0.36	24.5	0.35	24.0	0.34	23.5
RK 70 RK 71	2	50	<.01	.6	0.36	24.7	0.35	24.1	0.34	23.5
RK 70 RK 71	2 1/2	65	0.01	.7	0.37	25.4	0.36	24.7	0.35	24.0
RK 70 RK 71	3	80	0.01	.8	0.39	26.6	0.37	25.8	0.36	25.0
RK 70 RK 71	4	100	0.01	.9	0.40	27.3	0.38	26.4	0.37	25.5
RK 70	5	125	0.03	2	0.13	9.0	0.10	7.0	0.07	5.0
RK 70	6	150	0.04	2.5	0.14	10.0	0.11	7.5	0.07	5.0
RK 70	8	200	0.04	2.5	0.14	10.0	0.11	7.5	0.07	5.0

# Gestra® Check Valves • Wafer Style Guided Disc Check Valve

**RK 41**

Fits  
**ANSI 125**  
**ANSI 150**

Available Sizes: ½" to 8"  
(DN 15 to 200)

### Application

The RK 41 is used for preventing back flow in liquid and gas lines. Not to be used with pulsating flow.

### Valve Types

Brass body with stainless steel internals for sizes from ½" to 4".

Cast iron body with carbon steel internals for sizes from 5" to 8".

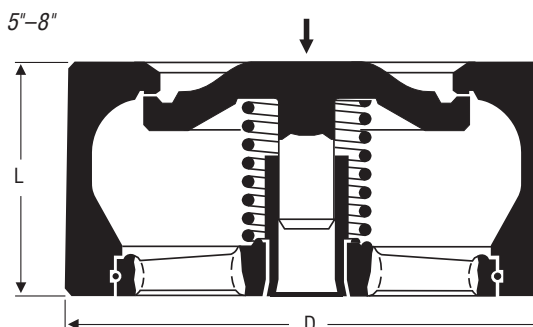
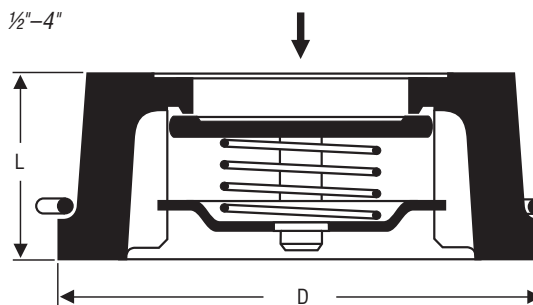
The RK 41 is used in standard services.

### Features and Benefits

- Wafer style, for easy installation between two ANSI flanges (either ANSI 125 or ANSI 150).
- Short overall length, less than 5½" for an 8" valve.
- Lightweight and of rugged construction.
- Metal-to-metal seats are lapped to minimize leakage.
- Can be installed in any position.
- Available with soft seats for bubble-tight shut off.
- Available with special springs for varying opening pressures.
- For ½" to 4" checks, the valve disc is guided by four ribs to ensure smooth operation with no binding. For sizes 5" and 8", the disc uses a center post inside a sleeve as a guide.

### Materials

- RK 41 (½"-4")  
Body – Brass  
Trim – A182 F 316  
Spring – A 313 Type 316
- RK 41 (5"-8")  
Body – A 126 Class A equivalent  
Trim – A182 F 304 / A126 Class B / A105  
Spring – A 313 Type 316



Pressure / Temperature Ratings						
Body Style		RK 41		RK 41		
Nominal Size	[inch]	1/2 - 4		5 - 8		
	[mm]	15 - 100		125 - 200		
Maximum Service Pressure	[psig]	230	200	185	230	185
	[barg]	16	14	13	16	13
Related Temperature	[°F]	248	392	482	248	392
	[°C]	120	200	250	120	200
Minimum Temperature		-76°F (-60°C)		14°F (-10°C)		

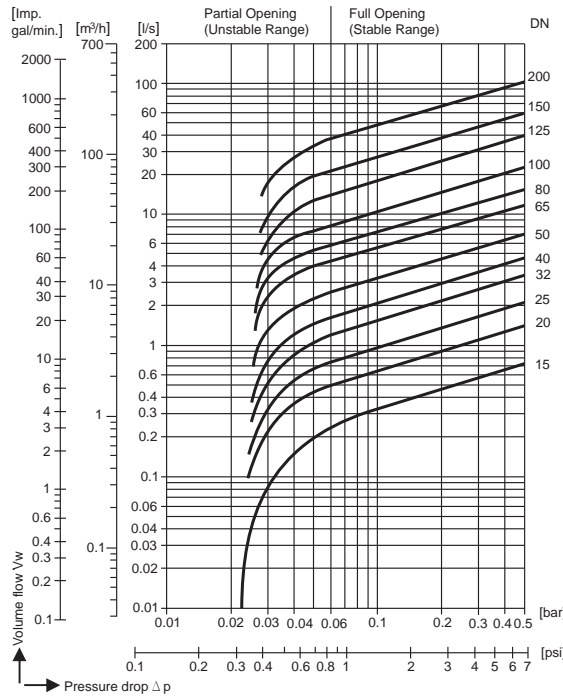
Dimensions and Weights													
Nominal Sizes	[inch]	1/2	3/4	1	1 1/4	1 1/2	2	2 1/2	3	4	5	6	8
	[mm]	15	20	25	32	40	50	65	80	100	125	150	200
Dimensions	D [inch]	1.6	1.9	2.2	2.8	3.2	3.7	4.5	5.2	6.0	7.2	8.2	10.4
	[mm]	40	47	56	72	82	95	115	132	152	184	209	264
	L [inch]	0.6	0.7	0.9	1.1	1.2	1.6	1.8	2.0	2.4	3.5	4.2	5.5
	[mm]	16	19	22	28	32	40	46	50	60	90	106	140
Approx. Weight	[lbs]	0.2	0.3	0.5	1.1	1.5	2.4	3.2	5.1	7.7	15	22	44
	[kg]	0.1	0.1	0.2	0.5	0.7	1.1	1.5	2.3	3.5	6.8	10	20

Fits  
ANSI 125  
ANSI 150

# Gestra® Check Valves • Wafer Style Guided Disc Check Valve

**RK 41**

Available Sizes: ½" to 8"  
(DN 15 to 200)



### Pressure Drop Chart

The curves given in the chart are valid for water at 68°F (20°C). To read the pressure drop for other fluids the equivalent water volume flowrate must be calculated and used in the graph.

The values indicated in the chart are applicable to spring-assisted valves with horizontal flow. With vertical flow insignificant deviations occur only within the range of partial opening.

### Body Pressure/Temperature Rating

The chart shows the maximum shell (body) pressure and temperature rating. Operating differential pressure is limited to the maximum service pressure shown in the chart.

### Material/Test Certificates

The following test certificates can be issued on request in accordance with EN 10204 – 2.2 and -3.1B. All inspection requirements have to be stated with the order. Test and/or Inspection certificates must be requested at time of order and cannot be issued after the equipment has been shipped from the factory.

### Available End Connections

Fits between: ANSI 125  
ANSI 150

### How to Order

Specify valve type and size.

For Example: RK 41 2" M/M

If special springs are required please consult Flowserve Gestra.

Valve Type		Size		Opening Pressures							
				Without Springs RK 70 Only				With Standard Springs			
				↑	↑	→	↓	↑	↑	→	↓
[Inch]	[mm]	[psi]	[mbar]	[psi]	[mbar]	[psi]	[mbar]	[psi]	[mbar]		
RK 41	RK 44	1/2	15	0.04	2.5	0.36	25	0.33	22.5	0.29	20
RK 41	RK 44	3/4	20	0.04	2.5	0.36	25	0.33	22.5	0.29	20
RK 41	RK 44	1	25	0.04	2.5	0.36	25	0.33	22.5	0.29	20
RK 41	RK 44	1 1/4	32	0.05	3.5	0.39	27	0.34	23.5	0.29	20
RK 41	RK 44	1 1/2	40	0.06	4.0	0.41	28	0.35	24.0	0.29	20
RK 41	RK 44	2	50	0.07	4.5	0.42	29	0.36	24.5	0.29	20
RK 41	RK 44	2 1/2	65	0.07	5.0	0.43	30	0.36	25.0	0.29	20
RK 41	RK 44	3	80	0.8	5.5	0.45	31	0.37	25.5	0.29	20
RK 41	RK 44	4	100	0.09	6.5	0.48	33	0.38	26.5	0.29	20
RK 41	RK 44	5	125	0.15	10.5	0.45	31.0	0.30	20.5	0.14	10
RK 41	RK 44	6	150	0.17	11.5	0.48	33.0	0.31	21.5	0.14	10
RK 41	RK 44	8	200	0.16	11.2	0.47	32.4	0.31	21.2	0.14	10
RK 41	RK 44			0.20	13.5	0.54	37.0	0.34	23.5		

# Gestra® Check Valves • Wafer Style Guided Disc Check Valve **RK 44 and RK 44S**

Fits  
**ANSI 125**  
**ANSI 150**

Available Sizes: ½" to 8"  
(DN 15 to 200)

### Application

For preventing back flow in liquid and gas lines. Not to be used with pulsating flow.

### Valve Types

**RK 44:** Bronze body and stainless steel internals for sizes from ½" to 4". Cast iron body with bronze internals for sizes from 5" to 8". The RK 44 is used in standard services.

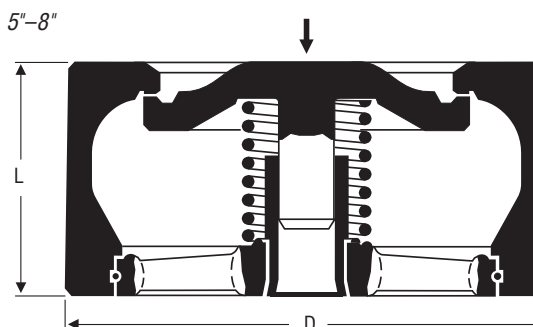
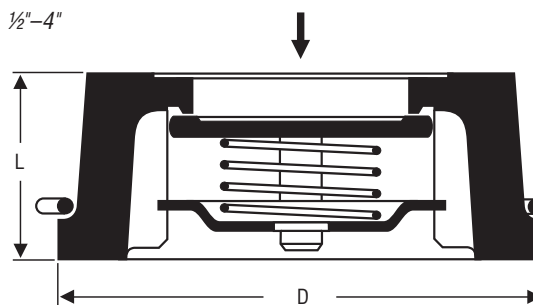
**RK 44s:** All bronze construction (including springs) for use in sea water or low temperature service where bronze is required (available in ANSI 125 FF only).

### Features and Benefits

- Wafer style, for easy installation between two ANSI flanges (either ANSI 125 or ANSI 150).
- Short overall length, less than 5½" for an 8" valve.
- Lightweight and of rugged construction.
- Metal-to-metal seats are lapped to minimize leakage.
- Can be installed in any position.
- Available with soft seats for bubble-tight shut off.
- The RK 44 is available with special springs for varying opening pressures.
- For ½" to 4" checks, the valve disc is guided by four ribs to ensure smooth operation with no binding. For sizes 5" and 8", the disc uses a center post inside a sleeve as a guide.

### Materials

- RK 44S – Bronze
- RK 44 (½"–4")  
Body – Bronze  
Trim – A182 F 316 equivalent  
Spring – A 313 Type 316
- RK 44 (5"–8")  
Body – A 126 Class A  
Trim – Bronze  
Spring – A 313 Type 316



Pressure / Temperature Ratings						
Body Style	RK 44			RK 44		
Nominal Size [inch]	1/2 - 4			5 - 8		
	[mm]			125 - 200		
Maximum Service Pressure [psig]	230	200	185	230	200	185
	[barg]			16 14 13		
Related Temperature [°F]	248	392	482	248	392	482
	[°C]			120 200 250		
Minimum Temperature	-328°F (-200°C)			14°F (-10°C)		

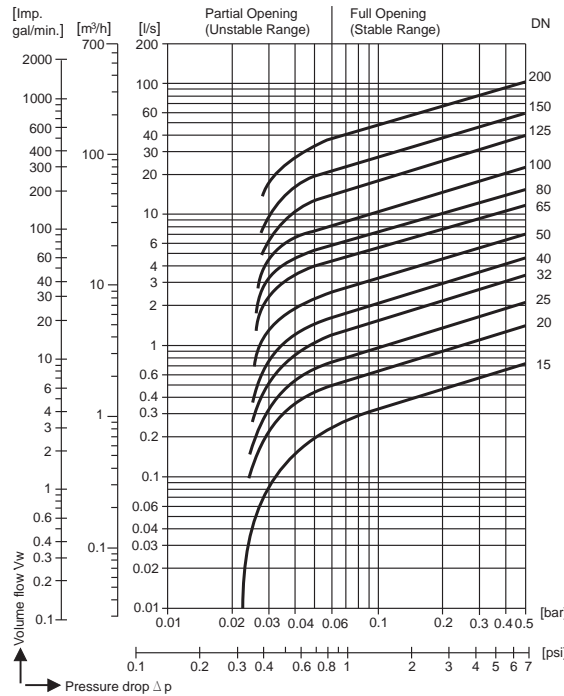
Dimensions and Weights													
Nominal Sizes	[inch]	1/2	3/4	1	1 1/4	1 1/2	2	2 1/2	3	4	5	6	8
	[mm]	15	20	25	32	40	50	65	80	100	125	150	200
Dimensions	D [inch]	1.7	1.9	2.3	2.9	3.3	3.8	4.6	5.2	6.0	7.2	8.2	10.4
	[mm]	42	49	58	74	84	97	117	132	152	184	209	264
	L [inch]	0.6	0.7	0.9	1.1	1.2	1.6	1.8	2.0	2.4	3.5	4.2	5.5
	[mm]	16	19	22	28	32	40	46	50	60	90	106	140
Approx. Weight	[lbs]	0.2	0.4	0.6	1.1	1.5	2.4	3.1	4.4	7.0	17	24	48
	[kg]	0.1	0.2	0.3	0.5	0.7	1.1	1.4	2.0	3.2	7.7	11	22

**Fits**  
**ANSI 125**  
**ANSI 150**

# Gestra® Check Valves • Wafer Style Guided Disc Check Valve

## RK 44 and RK 44s

**Available Sizes:** ½" to 8"  
(DN 15 to 200)



### Pressure Drop Chart

The curves given in the chart are valid for water at 68°F (20°C). To read the pressure drop for other fluids the equivalent water volume flowrate must be calculated and used in the graph.

The values indicated in the chart are applicable to spring-assisted valves with horizontal flow. With vertical flow insignificant deviations occur only within the range of partial opening.

### Body Pressure/Temperature Rating

The chart shows the maximum shell (body) pressure and temperature rating. Operating differential pressure is limited to the maximum service pressure shown in the chart.

### Material/Test Certificates

The following test certificates can be issued on request in accordance with EN 10204 – 2.2 and -3.1B. All inspection requirements have to be stated with the order. Test and/or Inspection certificates must be requested at time of order and cannot be issued after the equipment has been shipped from the factory.

### Available End Connections

Fits between: ANSI 125  
ANSI 150

### How to Order

Specify valve type and size.

For Example: RK 44 2" M/M

If special springs are required please consult Flowserve Gestra.

Valve Type		Opening Pressures									
		Size		Without Springs RK 70 Only		With Standard Springs					
				↑	↑	→	↓	↓	↓	↓	
[Inch]	[mm]	[psi]	[mbar]	[psi]	[mbar]	[psi]	[mbar]	[psi]	[mbar]		
RK 41 RK 44	1/2	15	0.04	2.5	0.36	25	0.33	22.5	0.29	20	
RK 41 RK 44	3/4	20	0.04	2.5	0.36	25	0.33	22.5	0.29	20	
RK 41 RK 44	1	25	0.04	2.5	0.36	25	0.33	22.5	0.29	20	
RK 41 RK 44	1 1/4	32	0.05	3.5	0.39	27	0.34	23.5	0.29	20	
RK 41 RK 44	1 1/2	40	0.06	4.0	0.41	28	0.35	24.0	0.29	20	
RK 41 RK 44	2	50	0.07	4.5	0.42	29	0.36	24.5	0.29	20	
RK 41 RK 44	2 1/2	65	0.07	5.0	0.43	30	0.36	25.0	0.29	20	
RK 41 RK 44	3	80	0.8	5.5	0.45	31	0.37	25.5	0.29	20	
RK 41 RK 44	4	100	0.09	6.5	0.48	33	0.38	26.5	0.29	20	
RK 41 RK 44	5	125	0.15	10.5	0.45	31.0	0.30	20.5	0.14	10	
RK 41 RK 44	6	150	0.17	11.5	0.48	33.0	0.31	21.5	0.14	10	
RK 41 RK 44	8	200	0.16	11.2	0.47	32.4	0.31	21.2	0.14	10	
RK 41 RK 44			0.20	13.5	0.54	37.0	0.34	23.5			



# Gestra® Check Valves • Wafer Style Guided Disc Check Valve

**RK 16**

Fits  
**ANSI 150**  
**ANSI 300**

Available Sizes: ½" to 4"  
(DN 15 to 100)

### Application

The RK 16 is used for preventing back flow in liquid and gas lines. Used as vacuum breakers on tanks or heat exchangers. Wide variety of specialty materials for use in aggressive media. Not to be used with pulsating flow.

### Valve Types

**RK 16b:** Body and internals equivalent to Hastelloy® B.

**RK 16c:** Body and internals equivalent to Hastelloy® C.

**RK 16i:** Inconel body and internals.

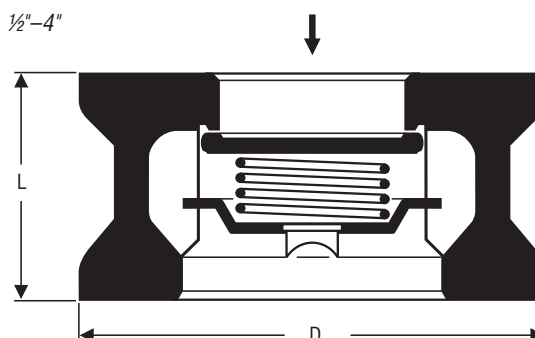
**RK 16t:** Titanium body and internals.

### Valve Seats

- Lapped Metal-to-Metal seats (Standard).
- For bubble tight shut-off, the following soft seats are available:
  - Ethylene Propylene (EPDM) for water, air, and condensate. Temperature Range: -40 to 302°F (-40 to 150°C).
  - Viton (FPM) for oils, gases and air. Temperature Range: -13 to 392°F (-25 to 200°C).
  - Teflon (PTFE) for oils, gases, and air. Temperature Range: -310 to 482°F (-190 to 250°C).

### Features and Benefits

- Wafer style, for easy installation between two ANSI flanges.
- Short overall length, less than ¾" for a 4" valve.
- Lightweight and of rugged construction.
- Metal-to-Metal seats (standard) are lapped to minimize leakage.
- Can be installed in any position.
- Available with soft seats for bubble-tight shut off.
- Available with special springs for varying opening pressures.
- Valve disc is guided by four ribs to ensure smooth operation with no binding.



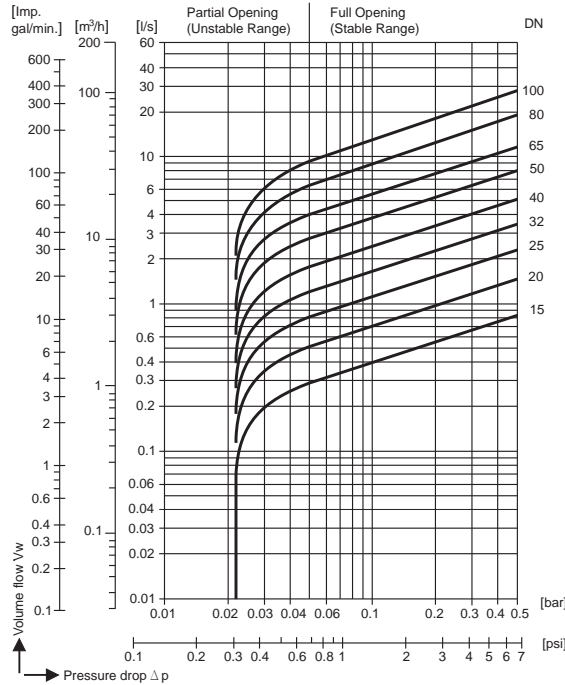
Dimensions and Weights									
Nominal Size		L		D ANSI 150 RF		D ANSI 300 RF		Weight	
[Inch]	[mm]	[Inch]	[mm]	[Inch]	[mm]	[Inch]	[mm]	[lbs]	[kgs]
1/2	15	1	25	1.8	46	2	52	.55	0.25
3/4	20	1.2	31.5	2.2	56	2.5	63	.88	0.40
1	25	1.4	35.5	2.6	66	2.8	72	1.3	0.57
1 1/4	32	1.6	40	3	75	3.2	81	1.8	0.83
1 1/2	40	1.8	45	3.3	85	3.7	93	2.6	1.20
2	50	2.2	56	4.1	104	4.3	108	4.7	2.15
2 1/2	65	2.5	63	4.8	123	5	128	7	3.20
3	80	2.8	71	5.3	135	5.8	147	9.9	4.50
4	100	3.1	80	6.8	173	7	179	15.2	6.90

Fits  
ANSI 150  
ANSI 300

# Gestra® Check Valves • Wafer Style Guided Disc Check Valve

## RK 16

**Available Sizes:** ½" to 4"  
(DN 15 to 100)



### Materials

Dependant on the version ordered. (i.e. RK 16b, Hastelloy® B)

### Pressure Drop Chart

The curves given in the chart are valid for water at 68°F (20°C). To read the pressure drop for other fluids the equivalent water volume flowrate must be calculated and used in the graph.

The values indicated in the chart are applicable to spring-assisted valves with horizontal flow. With vertical flow insignificant deviations occur only within the range of partial opening.

### Body Pressure/Temperature Rating

Please consult Gestra for pressure / temperature ratings for specific material ordered. Operating differential pressure is limited to the maximum service pressure shown in the chart.

### Material/Test Certificates

The following test certificates can be issued on request in accordance with EN 10204 – 2.2 and -3.1B. All inspection requirements have to be stated with the order. Test and/or Inspection certificates must be requested at time of order and cannot be issued after the equipment has been shipped from the factory.

### Available End Connections

Fits between: ANSI 150  
ANSI 300

### How to Order

Specify valve type and size.

For Example: RK 16B 2" M/M

If special springs are required please consult Flowserve Gestra.

RK 16 Size		Opening Pressures							
		Without Springs		With Standard Springs					
[Inch]	[mm]	↑ [psi]	↑ [mbar]	↑ [psi]	↑ [mbar]	→ [psi]	→ [mbar]	↓ [psi]	↓ [mbar]
1/2	15	0.04	2.5	0.36	25	0.33	22.5	0.29	20
3/4	20	0.04	2.5	0.36	25	0.33	22.5	0.29	20
1	25	0.04	2.5	0.36	25	0.33	22.5	0.29	20
1 1/4	32	0.05	3.5	0.39	27	0.34	23.5	0.29	20
1 1/2	40	0.06	4.0	0.41	28	0.35	24.0	0.29	20
2	50	0.07	4.5	0.42	29	0.36	24.5	0.29	20
2 1/2	65	0.07	5.0	0.43	30	0.36	25.0	0.29	20
3	80	0.08	5.5	0.45	31	0.37	25.5	0.29	20
4	100	0.09	6.5	0.48	33	0.38	26.5	0.29	20

# Gestra® Check Valves • Wafer Style Guided Disc Check Valve

**RK 26A**

Fits  
**ANSI 150**  
**ANSI 300**

Available Sizes: 1/2" to 4"  
(DN 15 to 100)

### Application

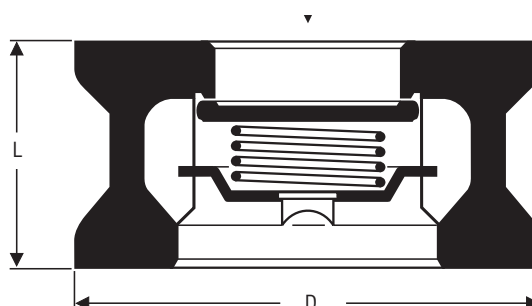
The RK 26A is used for preventing back flow in liquid and gas lines. Used as vacuum breakers on tanks or heat exchangers. Wide variety of specialty materials for use in aggressive media. Not to be used with pulsating flow.

### Valve Seats

- Lapped Metal-to-Metal seats (Standard).
- For bubble tight shut-off, the following soft seats are available:
- Ethylene Propylene (EPDM) for water, air, and condensate. Temperature Range: -40 to 302°F (-40 to 150°C).
- Viton (FPM) for oils, gases and air. Temperature Range: -13 to 392°F (-25 to 200°C).
- Teflon (PTFE) for oils, gases, and air. Temperature Range: -310 to 482°F (-190 to 250°C).

### Features and Benefits

- Wafer style, for easy installation between two ANSI flanges.
- Short overall length, less than 3 1/4" for a 4" valve.
- Lightweight and of rugged construction.
- Metal-to-Metal seats (standard) are lapped to minimize leakage.
- Can be installed in any position.
- Available with soft seats for bubble-tight shut off.
- Available with special springs for varying opening pressures.
- Valve disc is guided by four ribs to ensure smooth operation with no binding.



Pressure / Temperature Ratings							
Body Style	A	RK 26A					
Nominal Size	[inch]	1/2 - 4"					
	[mm]	15 - 100					
Maximum Service Pressure	[psig]	719	612	517	458	426	362
	[barg]	49.6	42.2	35.7	31.6	29.4	25
Related Temperature	[°F]	68	212	392	572	752*	1022*
	[°C]	20	100	200	300	400	550
Minimum Temperature	-328 °F (-200 °C)						

\* Nimonic springs must be used, special order only.

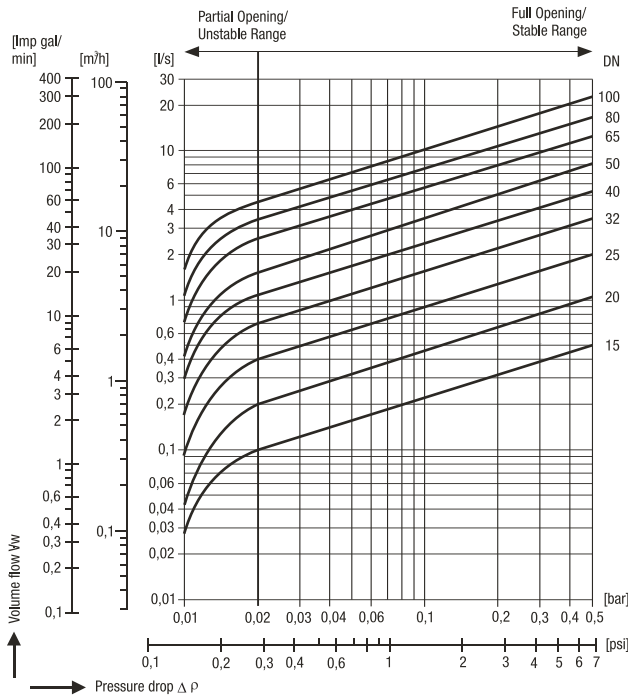
Dimensions and Weights									
Nominal Size		L		D ANSI 150 RF		D ANSI 300 RF		Weight	
[inch]	[mm]	[inch]	[mm]	[inch]	[mm]	[inch]	[mm]	[lbs]	[kgs]
1/2	15	1	25	1.8	46	2	52	.55	0.25
3/4	20	1.2	31.5	2.2	56	2.5	63	.88	0.40
1	25	1.4	35.5	2.6	66	2.8	72	1.3	0.57
1 1/4	32	1.6	40	3	75	3.2	81	1.8	0.83
1 1/2	40	1.8	45	3.3	85	3.7	93	2.6	1.20
2	50	2.2	56	4.1	104	4.3	108	4.7	2.15
2 1/2	65	2.5	63	4.8	123	5	128	7	3.20
3	80	2.8	71	5.3	135	5.8	147	9.9	4.50
4	100	3.1	80	6.8	173	7	179	15.2	6.90

Fits  
ANSI 150  
ANSI 300

## Gestra® Check Valves • Wafer Style Guided Disc Check Valve

**RK 26A**

**Available Sizes:** ½" to 4"  
(DN 15 to 100)



### Materials

Body – A351 CF8M

Disc and Spring Retainer – A182 F316

Spring – A313 Type 316

### Pressure Drop Chart

The curves given in the chart are valid for water at 68°F (20°C). To read the pressure drop for other fluids the equivalent water volume flowrate must be calculated and used in the graph.

The values indicated in the chart are applicable to spring-assisted valves with horizontal flow. With vertical flow insignificant deviations occur only within the range of partial opening.

### Body Pressure/Temperature Rating

The chart shows the maximum shell (body) pressure and temperature rating. Operating differential pressure is limited to the maximum service pressure shown in the chart.

### Material/Test Certificates

The following test certificates can be issued on request in accordance with EN 10204 – 2.2 and -3.1B. All inspection requirements have to be stated with the order. Test and/or Inspection certificates must be requested at time of order and cannot be issued after the equipment has been shipped from the factory.

### Available End Connections

Fits between: ANSI 150  
ANSI 300

### How to Order

Specify valve type and size.

For Example: RK 26A 2" M/M

If special springs are required please consult Flowserve Gestra.

Opening Pressures										
RK 26A Size	With out springs				With Standard Springs					
	[inch]	[mm]	[psi]	[mbar]	[psi]	[mbar]	[psi]	[mbar]	[psi]	[mbar]
1/2	15	0.04	2.5	0.14	10	0.11	7.5	0.07	5	
3/4	20	0.04	2.5	0.14	10	0.11	7.5	0.07	5	
1	25	0.04	2.5	0.14	10	0.11	7.5	0.07	5	
1 1/4	32	0.05	3.5	0.17	12	0.12	8.5	0.07	5	
1 1/2	40	0.06	4.0	0.19	13	0.13	9	0.07	5	
2	50	0.07	4.5	0.20	14	0.14	9.5	0.07	5	
2 1/2	65	0.07	5.0	0.22	15	0.14	10	0.07	5	
3	80	0.08	5.5	0.23	16	0.15	10.5	0.07	5	
4	100	0.09	6.5	0.26	18	0.17	11.5	0.07	5	

# Gestra® Check Valves • Wafer Style Guided Disc Check Valve **RK 86 and RK 86A**

Fits  
**ANSI 150**  
**ANSI 300**

Available Sizes: ½" to 8"  
(DN 15 to 200)

### Application

The RK 86 and RK 86A are used for preventing back flow in liquid and gas lines. Used as vacuum breakers on tanks or heat exchangers. Not to be used with pulsating flow.

### Valve Types

**RK 86:** Ferritic stainless steel body with stainless steel internals. Lapped metal-to-metal seats.

**RK 86A:** Stainless steel body and internals (½"-4").

### Valve Seats

Lapped metal-to-metal seats only. For bubble tight shut-off, the following soft seats are available:

**Ethylene Propylene (EPDM)** for water, air and condensate.  
Temperature Range: -58 to 302°F (-50 to 150°C).

**Viton (FKM)** for oils, gases and air  
Temperature Range: -13 to 392°F (-25 to 200°C).

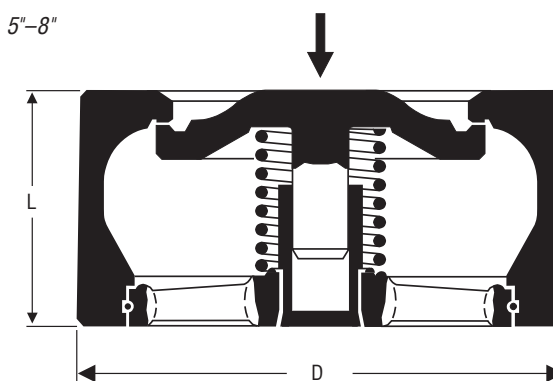
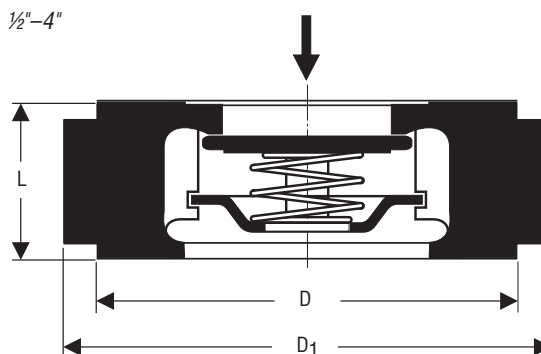
**Teflon (PTFE)** for oils, gases, and air.  
Temperature Range: -13 to 392°F (-25 to 200°C).

### Features and Benefits

- Universal centering ring allows the check valve to fit between ANSI 150RF, ANSI 300RF and DIN flanges.
- Wafer style, for easy installation between two ANSI flanges.
- Short overall length, less than 2½" for a 4" valve.
- Lightweight and of rugged construction.
- Metal-to-Metal seats are lapped to minimize leakage.
- Can be installed in any position.
- Valve disc is guided by four ribs to ensure smooth operation with no binding.
- Ground strap tapping provided.

### Materials

- RK 86 ½"-4"  
Body – A743 CA 6 NM  
Disc – A182 F316  
Spring – A313 Type 316  
Spring Retainer – A182 F316
- RK 86 5"-8"  
Body – A216 WCB  
Disc – A182 F6  
Spring – A313 Type 316  
Guide Support – A105



Pressure / Temperature Ratings											
Valve Type	Service Temperature	°F	68	212	392	572	662	752	932	1022	Minimum Temperature
		°C	20	100	200	300	350	400	500	550	
RK 86	1/2" - 4"	psi	740	673	637	564	535				14 °F
	DN 15 - 100	bar	51	46.4	43.9	38.9	36.9				-10 °C
	5" - 8"	psi	580	580	508	406	348	305			14 °F
	DN 125 - 200	bar	40	40	35	28	24	21			-10 °C
RK 86A	1/2" - 4"	psi	719	613	519	458	441	425	396	348	-238 °F
	DN 15 - 100	bar	50	42.3	35.8	31.6	30.4	29.3	27.3	24	-200 °C
	5" & 6"	psi	580	479	435	377	363	348	334	319	-238 °F
	DN 125 & 150	bar	40	33	30	26	25	24	23	22	-200 °C
	8"	psi	580	522	435	406	392	377	348	334	14 °F
	DN 200	bar	40	36	30	28	27	26	24	23	-10 °C

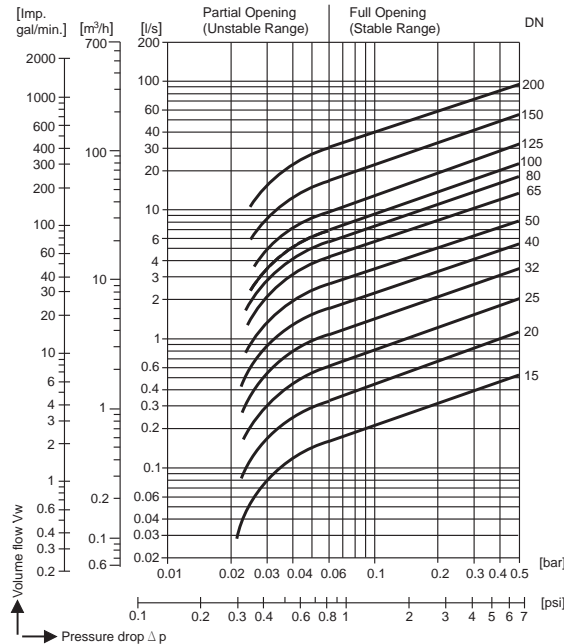
Dimensions and Weights													
Nominal Sizes	[inch]	1/2	3/4	1	1 1/4	1 1/2	2	2 1/2	3	4	5	6	8
	[mm]	15	20	25	32	40	50	65	80	100	125	150	200
Dimensions	D [inch]	1.7	2.1	2.5	2.9	3.3	3.8	4.3	44.4	5.9	7.6	8.7	10.8
	[mm]	44	53	64	73	83	96	110	1128	151	194	220	275
	D1 [inch]	2.6	3.0	3.2	3.7	4.1	4.6	5.4	6.2	7.3	7.3	8.7	10.8
	[mm]	67	76	82	93	104	118	136	158	186	194	220	275
L [inch]	0.6	0.7	0.9	1.1	1.2	1.6	1.8	2.0	2.4	3.5	4.2	5.5	
	[mm]	16	19	22	28	31.5	40	46	50	60	90	106	140
Approx. Weight	[lbs]	0.6	0.8	1.1	1.8	2.5	3.9	5.3	7.4	11.7	22	29	53
	[kg]	0.3	0.4	0.5	0.8	1.1	1.8	2.4	3.4	5.3	10	13	24

Fits  
ANSI 150  
ANSI 300

## Gestra® Check Valves • Wafer Style Guided Disc Check Valve

### RK 86 and RK 86A

Available Sizes: ½" to 8"  
(DN 15 to 200)



#### Materials (continued)

- RK 86A ½"–4"  
Body – A351 CF8C  
Disc – A182 F316  
Spring – A313 Type 316  
Spring Retainer – A182 F316
- RK 86A 5"–8"  
Body – A351 CF8M  
Disc – A182 F6  
Spring – A313 Type 316  
Guide Support – A105

#### Pressure Drop Chart

The curves given in the chart are valid for water at 68°F (20°C). To read the pressure drop for other fluids the equivalent water volume flowrate must be calculated and used in the graph.

The values indicated in the chart are applicable to spring-assisted valves with horizontal flow. With vertical flow insignificant deviations occur only within the range of partial opening.

#### Body Pressure/Temperature Rating

The chart shows the maximum shell (body) pressure and temperature rating. Operating differential pressure is limited to the maximum service pressure shown in the chart.

#### Material/Test Certificates

The following test certificates can be issued on request in accordance with EN 10204 – 2.2 and -3.1B. All inspection requirements have to be stated with the order. Test and/or Inspection certificates must be requested at time of order and cannot be issued after the equipment has been shipped from the factory.

#### Available End Connections

Fits between: ANSI 150  
ANSI 300

#### How to Order

Specify valve type and size.

For Example: RK 86 2" M/M

Valve Type	Size		Opening Pressures							
			Without Springs				With Standard Springs			
	[Inch]	[mm]	[psi]	[mbar]	[psi]	[mbar]	[psi]	[mbar]	[psi]	[mbar]
RK 86	½	15	0.04	2.5	0.36	25	0.33	22.5	0.29	20
RK 86A										
RK 86	¾	20	0.04	2.5	0.36	25	0.33	22.5	0.29	20
RK 86A										
RK 86	1	25	0.04	2.5	0.36	25	0.33	22.5	0.29	20
RK 86A										
RK 86	1¼	32	0.05	3.5	0.39	27	0.34	23.5	0.29	20
RK 86A										
RK 86	1½	40	0.06	4.0	0.41	28	0.35	24.0	0.29	20
RK 86A										
RK 86	2	50	0.07	4.5	0.42	29	0.36	24.5	0.29	20
RK 86A										
RK 86	2½	65	0.07	5.0	0.43	30	0.36	25.0	0.29	20
RK 86A										
RK 86	3	80	0.08	5.5	0.45	31	0.37	25.5	0.29	20
RK 86A										
RK 86	4	100	0.10	6.6	0.48	33	0.38	26.5	0.29	20
RK 86A										
RK 86	5	125	0.17	12.0	0.49	34	0.32	22.0	0.14	10
RK 86A										
RK 86	6	150	0.20	13.5	0.54	37	0.34	23.5	0.14	10
RK 86A										
RK 86	8	200	0.23	16.0	0.61	42	0.38	26.0	0.14	10
RK 86A										

# Gestra® Check Valves • Wafer Style Guided Disc Check Valve

**RK 76**

Fits  
**ANSI 125**  
**ANSI 150**  
**ANSI 300**

Available Sizes: 1/2" to 4"  
(DN 15 to 200)

### Application

The RK 76 is used for preventing back flow in liquid and gas lines. Used as vacuum breakers on tanks or heat exchangers. Not to be used with pulsating flow.

### Valve Types

Ferritic stainless steel body with stainless steel internals.

### Valve Seats

Lapped metal-to-metal seats only.

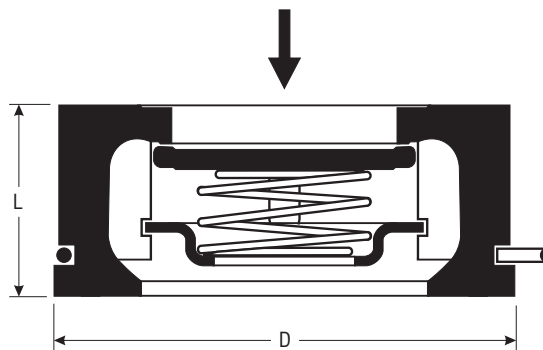
Soft seats are not available.

### Features and Benefits

- Universal centering ring allows the check valve to fit between ANSI 125F, ANSI 150RF and ANSI 300RF flanges.
- Wafer style, for easy installation between two ANSI flanges.
- Short overall length, less than 2 1/2" for a 4" valve.
- Lightweight and of rugged construction.
- Metal-to-Metal seats are lapped to minimize leakage.
- Can be installed in any position.
- Valve disc is guided by four ribs to ensure smooth operation with no binding.

### Materials

- Body – A217 CA 15
- Disc – A182 F316
- Spring – A313 Type 316
- Spring Retainer – A182 F316



Pressure / Temperature Ratings				
Body Style	A	RK 16		
Nominal Size	[inch]	1/2 - 4		
	[mm]	15 - 100		
Maximum Service Pressure	[psig]	580	508	464
	[barg]	40	35	32
Related Temperature	[°F]	68	212	392
	[°C]	20	100	200
Minimum Temperature	14 °F (-10 °C)			

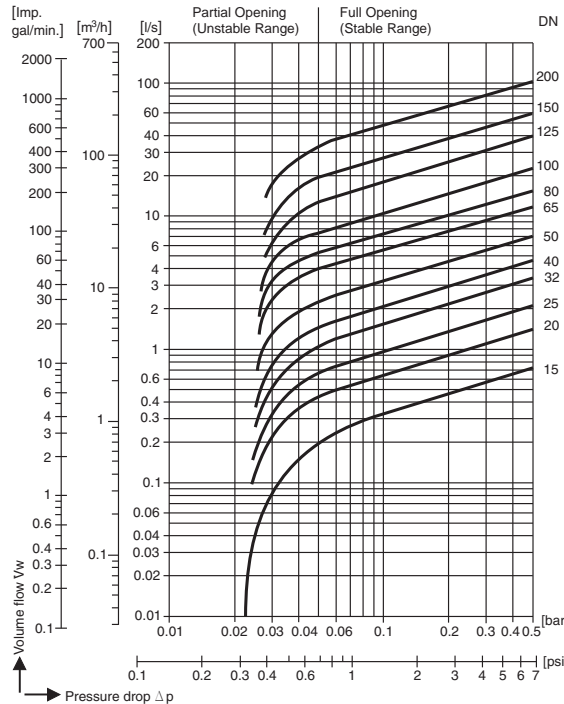
Dimensions and Weights										
Nominal Sizes	[inch]	1/2	3/4	1	1 1/4	1 1/2	2	2 1/2	3	4
	[mm]	15	20	25	32	40	50	65	80	100
Dimensions	D [inch]	1.8	2.2	2.6	3.0	3.3	3.9	4.6	5.3	6.3
	[mm]	45	55	65	75	85	98	118	134	159
	L [inch]	0.6	0.7	0.9	1.1	1.2	1.6	1.8	2.0	2.4
	[mm]	16	19	22	28	32	40	46	50	60
Approx. Weight	[lbs]	0.4	0.7	1.0	1.5	2.0	3.3	4.6	7.5	11.4
	[kg]	0.2	0.3	0.5	0.7	0.9	1.5	2.1	3.4	5.2

Fits  
**ANSI 125**  
**ANSI 150**  
**ANSI 300**

## Gestra® Check Valves • Wafer Style Guided Disc Check Valve

**RK 76**

**Available Sizes:** ½" to 4"  
 (DN 15 to 200)



### Pressure Drop Chart

The curves given in the chart are valid for water at 68°F (20°C). To read the pressure drop for other fluids the equivalent water volume flowrate must be calculated and used in the graph.

The values indicated in the chart are applicable to spring-assisted valves with horizontal flow. With vertical flow insignificant deviations occur only within the range of partial opening.

### Body Pressure/Temperature Rating

The chart shows the maximum shell (body) pressure and temperature rating. Operating differential pressure is limited to the maximum service pressure shown in the chart.

### Material/Test Certificates

Test certificates can be issued on request in accordance with EN 10204 – 2.2 and -3.1B. All inspection requirements have to be stated with the order. Test and/or Inspection certificates must be requested at time of order and cannot be issued after the equipment has been shipped from the factory.

### Available End Connections

Fits between: ANSI 125  
 ANSI 150  
 ANSI 300

### How to Order

Specify valve type and size.

For Example: RK 76 2"

If special springs are required please consult Flowserve Gestra.

Opening Pressures							
Size		With Standard Springs					
		↑		→		↓	
[Inch]	[mm]	[psi]	[mbar]	[psi]	[mbar]	[psi]	[mbar]
1/2	15	0.36	25	0.33	22.5	0.29	20
3/4	20	0.36	25	0.33	22.5	0.29	20
1	25	0.36	25	0.33	22.5	0.29	20
1 1/4	32	0.39	27	0.34	23.5	0.29	20
1 1/2	40	0.41	28	0.35	24.0	0.29	20
2	50	0.42	29	0.36	24.5	0.29	20
2 1/2	65	0.43	30	0.36	25.0	0.29	20
3	80	0.45	31	0.37	25.5	0.29	20
4	100	0.48	33	0.38	26.5	0.29	20



# Gestra® Check Valves • Wafer Style Guided Disc Check Valve

**RK 49**

Fits  
**ANSI 400**  
**ANSI 600**  
**ANSI 900**

Available Sizes: ½" to 8"  
(DN 15 to 200)

### Application

The RK 49 is used for preventing back flow of liquids, gases or vapors. Particularly suited for services at high pressures and temperatures.

### Valve Types

Austenitic stainless steel body and stainless steel internals from ½" to 2½" (ANSI 600/900 with centering ring). Cast alloy steel body and stainless steel internals from 3" to 8".

### Valve Seats

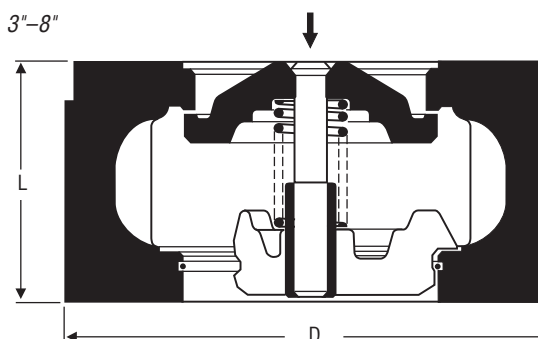
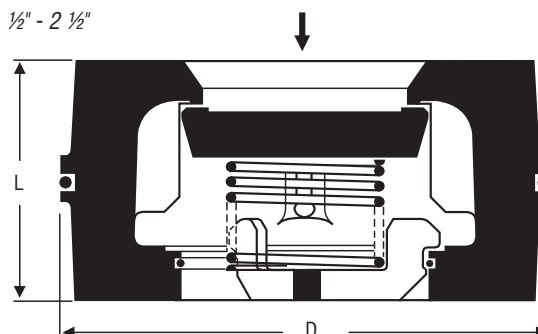
Lapped metal-to-metal seats only.

### Features and Benefits

- Wafer style, for easy installation between two ANSI flanges.
- Short overall length, less than ¾" for a 4" valve.
- Lightweight and of rugged construction.
- Metal-to-Metal seats are lapped to minimize leakage.
- Can be installed in any position.
- For ½" to 2½" sizes, the valve disc is guided by four ribs to insure smooth operation with no binding. For sizes 3"–8", the disc uses a center post inside a sleeve as a guide for more stability.

### Materials

- ½"–2½" RK 49  
Body – A351 CF8M  
Disc – X8 CrNiMoBNb 16 16  
Spring – Nimonic  
Spring Retainer – A182 F316  
Guide Ribs – A351 CF8M
- 3"–8" RK 49  
Body – A217 WC5  
Disc – X8 CrNiMoBNb 16 16  
Spring – Nimonic  
Spring Retainer – A182 F316  
Guide Ribs – X20 CrMoV 12 1



Pressure / Temperature Ratings								
Body Style		RK 49						
Nominal Size	[inch] [mm]	1/2 - 8 15 - 200						
Maximum Service Pressure	[psig] [barg]	2320 160	2219 153	2117 146	2016 139	1711 118	1146 79	508 35
Related Temperature	[°F] [°C]	572 300	662 350	752 400	842 450	932 500	968 520	1022 550
Minimum Temperature		14 °F (-10 °C)						

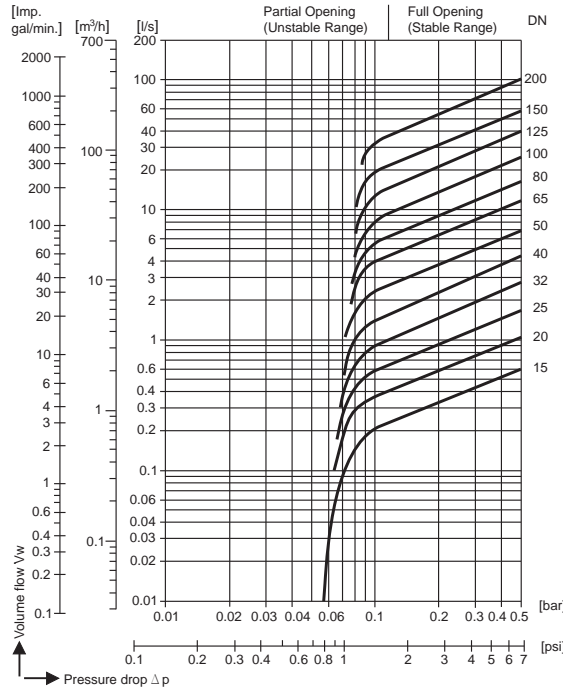
Dimensions and Weights													
Nominal Sizes	[inch] [mm]	1/2 15	3/4 20	1 25	1 1/4 32	1 1/2 40	2 50	2 1/2 65	3 80	4 100	5 125	6 150	8 200
Dimensions	D [inch] [mm]	2.1 54	2.5 63	2.9 74	3.3 84	3.7 95	4.3 110	5.1 130	5.8 147	6.8 173	8.2 209	9.6 245	11.9 301
	L [inch] [mm]	1.0 25	1.2 31.5	1.4 35.5	1.6 40	1.8 45	2.2 56	2.5 63	2.8 71	3.1 80	4.3 110	4.9 125	6.3 160
Approx. Weight	[lbs]	0.9	1.5	2.2	3.1	4.4	6.6	10.3	15.6	26.6	40	65	105
	[kg]	0.4	0.7	1	1.4	2	3	4.7	7.1	12.1	18.2	29.4	47.5

Fits  
**ANSI 400**  
**ANSI 600**  
**ANSI 900**

## Gestra® Check Valves • Wafer Style Guided Disc Check Valve

**RK 49**

**Available Sizes:** ½" to 8"  
 (DN 15 to 200)



### Pressure Drop Chart

The curves given in the chart are valid for water at 68°F (20°C). To read the pressure drop for other fluids the equivalent water volume flowrate must be calculated and used in the graph.

The values indicated in the chart are applicable to spring-assisted valves with horizontal flow. With vertical flow insignificant deviations occur only within the range of partial opening.

### Body Pressure/Temperature Rating

The chart shows the maximum shell (body) pressure and temperature rating. Operating differential pressure is limited to the maximum service pressure shown in the chart.

### Material/Test Certificates

The following test certificates can be issued on request in accordance with EN 10204 – 2.2 and -3.1B. All inspection requirements have to be stated with the order. Test and/or Inspection certificates must be requested at time of order and cannot be issued after the equipment has been shipped from the factory.

### Available End Connections

Fits between: ANSI 600  
 ANSI 900

### How to Order

Specify valve type and size.

For Example: RK 49 2" ANSI 900RF

If special springs are required please consult Flowserve Gestra.

Size		Opening Pressures							
		Without Springs		With Standard Springs					
[Inch]	[mm]	[psi]	[mbar]	[psi]	[mbar]	[psi]	[mbar]	[psi]	[mbar]
1/2	15	0.24	16.5	1.06	73	0.82	56.5	0.58	40
3/4	20	0.25	17.0	1.07	74	0.83	57.0	0.58	40
1	25	0.26	18.0	1.10	76	0.84	58.0	0.58	40
1 1/4	32	0.26	18.0	1.10	76	0.84	58.0	0.58	40
1 1/2	40	0.28	19.5	1.14	79	0.86	59.5	0.58	40
2	50	0.32	22.0	1.22	84	0.90	62.0	0.58	40
2 1/2	65	0.33	23.0	1.26	87	0.91	63.0	0.58	40
3	80	0.25	17.5	1.09	75	0.83	57.5	0.58	40
4	100	0.29	20.0	1.16	80	0.87	60.0	0.58	40
5	125	0.33	23.0	1.25	86	0.91	63.0	0.58	40
6	150	0.35	24.0	1.28	88	0.93	64.0	0.58	40
8	200	0.42	29.0	1.42	98	1.00	69.0	0.58	40

# Gestra® Check Valves • Wafer Style Swing Check Valve

**CB 14**

Fits  
**ANSI 125**  
**ANSI 150**

Available Sizes: 2" to 12"  
(DN 50 to 300)

### Application

The CB 14 is used for preventing back flow in liquid and gas lines. For use in non-corrosive service up to 176°F.

### Features and Benefits

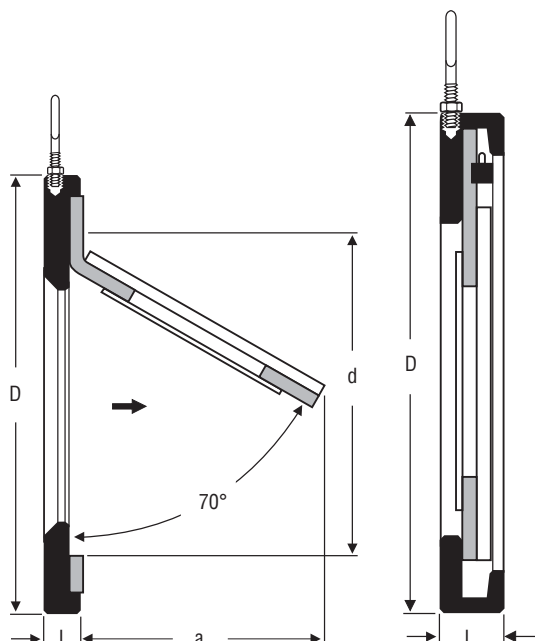
- Wafer style for easy installation between either ANSI 125 or ANSI 150 flanges.
- Short overall length, less than 1¾" for a 12" diameter valve.
- Lightweight and of rugged construction.
- Buna N soft seats for bubble-tight shut off.
- Provided with eyebolt for rapid, easy installation and orientation.
- Galvanized steel body with Buna-N flap reinforced with galvanized steel plates for long cycle life.
- Design ensures full opening at low flow rates to minimize chattering.
- Low pressure drop due to large opening angle of 70°. Excellent application on low pressure or vacuum service.
- Zero opening pressures for horizontal flows.
- Simple design with no springs or pivots.

### Valve Seats

Buna N (NBR) soft seats only.

### Materials

- Body and reinforcing plate – Galvanized steel (RSt 37-2)
- Disc and spring Retainer – Buna-N (NBR)



Pressure / Temperature Ratings					
Body Style	CB 14				
Nominal Size	[inch]	2 - 12			
	[mm]	50 - 300			
Maximum Service Pressure	[psig]	230	145	85	60
	[barg]	16	10	6	4
Related Temperature	[°F]	68	104	140	176
	[°C]	20	40	60	80
Minimum Temperature	14°F (-10°C)				

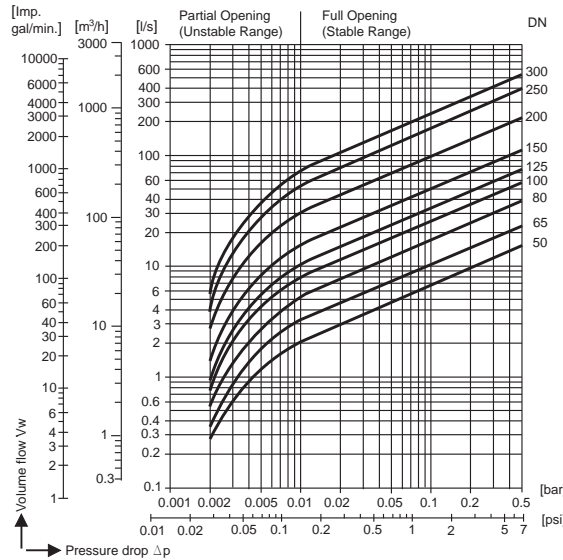
Dimensions and Weights										
Nominal Sizes	[inch]	2	2 1/2	3	4	5	6	8	10	12
	[mm]	50	65	80	100	125	150	200	250	300
Dimensions	D [inch]	3.9	4.6	5.2	6.1	7.2	8.2	10.4	12.6	14.8
	[mm]	98	118	132	154	184	209	264	319	375
	d [inch]	1.9	2.5	3	3.9	4.9	5.8	7.7	9.5	11.3
	[mm]	47	64	75	98	124	148	196	242	288
	L [inch]	0.6	0.6	0.6	0.6	0.6	0.6	0.7	1.4	1.7
	[mm]	14	14	14	14	16	16	18	35	43
a [inch]	[inch]	1.8	2.4	2.8	3.5	4.5	5.7	7.3	8.7	10.6
	[mm]	45	60	70	90	115	145	185	220	270
Approx. Weight	[lbs]	1.5	2.2	3.1	3.3	5.5	7.3	12.1	24.6	30.8
	[kg]	0.7	1.0	1.4	1.5	2.5	3.3	5.5	11.2	14.0

Fits  
ANSI 125  
ANSI 150

## Gestra® Check Valves • Wafer Style Swing Check Valve

**CB 14**

**Available Sizes:** 2" to 12"  
(DN 50 to 300)



### Pressure Drop Chart

The curves given in the chart are valid for water at 68°F (20°C). To read the pressure drop for other fluids the equivalent water volume flowrate must be calculated and used in the graph.

The values indicated in the chart are applicable to CB14 valves with horizontal flow. Insignificant deviations occur for vertical flow only within the range of partial opening.

### Body Pressure/Temperature Rating

The chart shows the maximum shell (body) pressure and temperature rating. Operating differential pressure is limited to the maximum service pressure shown in the chart.

### Material/Test Certificates

Test certificates can be issued on request in accordance with EN 10204 – 2.2 and -3.1B. All inspection requirements have to be stated with the order. Test and/or Inspection certificates must be requested at time of order and cannot be issued after the equipment has been shipped from the factory.

### Available End Connections

Fits between: ANSI 125  
ANSI 150

### How to Order

Specify valve type and size.

For Example: CB 14 4"

**NOTE:** These valves are designed to fit between either ANSI 125 or ANSI 150 flanges. There is no need to specify which ANSI flanges are used.

Opening Pressures							
Size		Without Springs					
		↑	→	↓	Not for use in Vertical Downward Flow		
[Inch]	[mm]	[psi]	[mbar]	[psi]	[mbar]	[psi]	[mbar]
2 - 6	50 - 150	0.11	8	0	0	Not for use in Vertical Downward Flow	
8 - 12	200 - 300	0.22	15	0	0	Not for use in Vertical Downward Flow	

# Gestra® Check Valves • Wafer Style Swing Check Valve

## CB 24S, CB 26, CB 26A

Fits  
**ANSI 125**  
**ANSI 150**  
**ANSI 300**

Available Sizes: 2" to 12"  
(DN 50 to 300)

### Application

The CB 24S, CB 26 and CB 26A are used for preventing back flow in liquid, steam and gas lines.

### Valve Types

**CB 24S:** All-bronze construction recommended for use in seawater or low temperature service (ANSI 125/ANSI 150 only).

**CB 26:** Carbon steel body with stainless steel springs. Sizes up to 3" have a stainless steel flap; larger sizes have a ductile iron flap.

**CB 26A:** 316 SST body and internals. Coupled with the EPDM or FKM seats, the CB 26a can be used in many low temperature sour gas applications that require low pressure drop bubble-tight check valves.

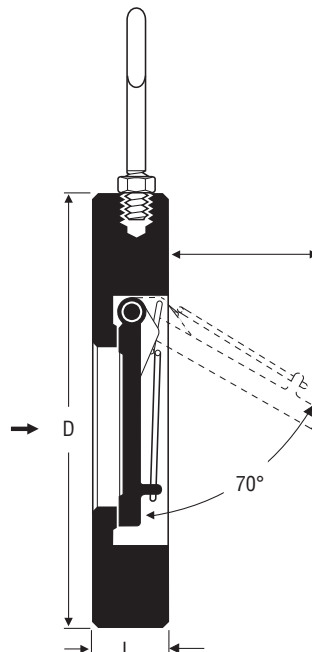
### Valve Seats

Lapped Metal-to-Metal seats (standard). For bubble-tight shut off, the following soft seats are available (EPDM and FKM are available with CB 26 and CB 26a only):

- Buna-N (NBR): Used primarily for water service. Temperature Range: -22°F to 230°F. For CB 24s only.
- Ethylene Propylene (EPDM): Used for water, air, and condensate. Temperature Range: -58°F to 302°F (-50° to 150°C).
- Viton (FKM): Used primarily for oils, gases and air. Temperature Range: -13°F to 392°F (-25° to 200°C).

### Features and Benefits

- Wafer style, for easy installation between two ANSI flanges.
- Short overall length, less than 2¼" for a 12" valve. Extremely low weight for easy installation.
- Lightweight and of rugged construction.
- Metal-to-Metal seats are lapped to minimize leakage and provide tight shut off.
- Available with soft seats for bubble-tight shut-off.
- Provided with eyebolt for rapid, easy installation.
- Low pressure drop due to large opening angle of 60°. These check valves are excellent for applications on low pressure or vacuum systems.



Pressure / Temperature Ratings				
Body Style	CB 24s			
Nominal Size	[inch]	2 - 12		
	[mm]	50 - 300		
Design		with Bronze Springs	Without Springs	
Maximum Service Pressure	[psig]	230	230	185
	[barg]	16	16	13
Related Temperature	[°F]	194	248	482
	[°C]	90	120	250
Minimum Temperature	-328°F (-200°C)			

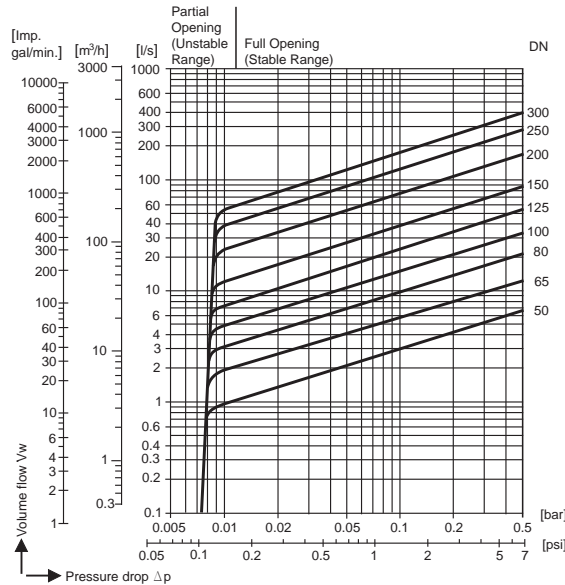
Dimensions and Weights										
Nominal Sizes	[inch]	2	2 1/2	3	4	5	6	8	10	12
	[mm]	50	65	80	100	125	150	200	250	300
Dimensions	D [inch]	3.9	4.6	5.2	6.1	7.2	8.2	10.4	12.6	14.8
	[mm]	98	118	132	154	184	209	264	319	375
	L [inch]	0.7	0.8	0.9	1.1	1.3	1.3	1.7	1.9	2.0
	[mm]	17	20	24	27	32	32	42	47	52
	a [inch]	1.6	2.0	2.3	2.8	3.5	4.4	5.9	7.2	8.5
	[mm]	40	50	58	72	88	112	150	182	216
Approx. Weight	[lbs]	2.0	3.1	4.4	6.8	11.4	14.7	30.1	50.4	72.2
	[kg]	0.9	1.1	2.0	3.1	5.2	6.7	13.7	22.9	32.8

Fits  
**ANSI 125**  
**ANSI 150**  
**ANSI 300**

## Gestra® Check Valves • Wafer Style Swing Check Valve

**CB 24S, CB 26, CB 26A**

**Available Sizes:** 2" to 12"  
 (DN 50 to 300)



### Materials

- Body
  - CB 24S – Bronze B505 C90 700
  - CB 26 – Carbon Steel A105
  - CB 26A – Stainless Steel A182 F316
- Flap
  - CB 24S – Bronze B148 Alloy 952
  - CB 26 – A352 CF 8 MC
  - CB 26A – A351 CF8 MC

### Pressure Drop Chart

The curves given in the chart are valid for water at 68°F (20°C). To read the pressure drop for other fluids the equivalent water volume flowrate must be calculated and used in the graph. The values indicated in the chart are applicable to CB2\_ series with horizontal flow. Insignificant flow deviations occur for vertical orientation only within the range of partial opening.

### Body Pressure/Temperature Rating

The chart shows the maximum shell (body) pressure and temperature rating. Operating differential pressure is limited to the maximum service pressure shown in the chart.

### Material/Test Certificates

Test certificates can be issued on request in accordance with EN 10204 – 2.2 and -3.1B. All inspection requirements have to be stated with the order. Test and/or Inspection certificates must be requested at time of order and cannot be issued after the equipment has been shipped from the factory.

### Available End Connections

Fits between: ANSI 125  
 ANSI 150  
 ANSI 300

### How to Order

Specify valve type and size.

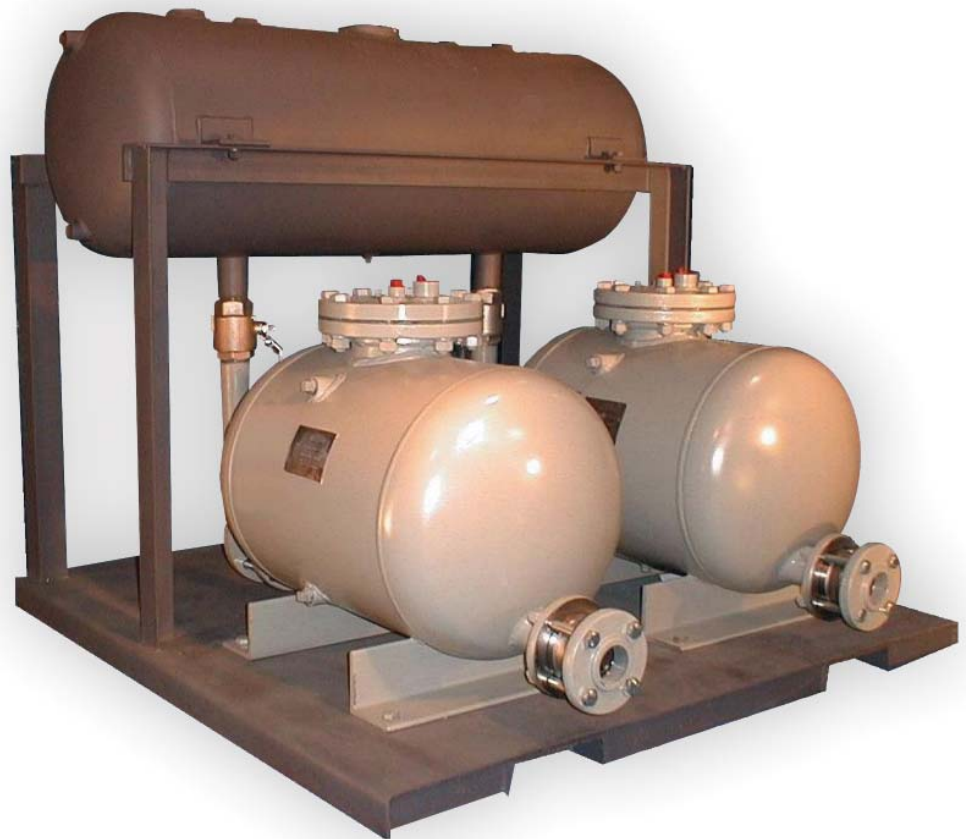
For Example: CB 26 4" ANSI 150

Pressure / Temperature Ratings								
Type CB 26 Maximum Service Pressure 2" - 8" (DN 50 - 200)	[psig]	580	550	435	390	350	290	—
	[bar]	40	38	30	27	24	20	—
Type CB 26 Maximum Service Pressure 10" - 12" (DN 250 - 300)	[psig]	580	465	390	350	305	—	—
	[bar]	40	32	27	24	21	—	—
Type CB 26a Maximum Service Pressure 2" - 12" (DN 50 - 300)	[psig]	580	550	465	435	420	405	390
	[bar]	40	38	32	30	29	28	27
Related Temperature	[°F]	68	212	392	482	572	662	752
	[°C]	20	100	200	250	300	350	400
Minimum Temperature		14°F (-10°C)						

Opening Pressures										
Size	Without 5 springs									
	[inch]	[mm]	[psi]	[mbar]	[psi]	[mbar]	[psi]	[mbar]	[psi]	[mbar]
2" - 6"	50 - 150	0.07	5	0.17	12	0.1	7	Not for use in Vertical Downward Flow		
8" - 12"	200 - 300	0.11	8	0.22	15	0.1	7			



*Special Equipment and Vessels for Heat Recovery*



This page intentionally left blank.



## Gestra® Pump • Non-Electric Pump GestraPump™

FPS-11

**150**  
psi  
Maximum  
(10.3 bar)

**Available Sizes:** Up to 1" Inlet  
Up to 1" Outlet

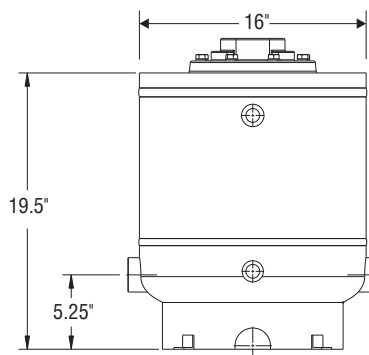
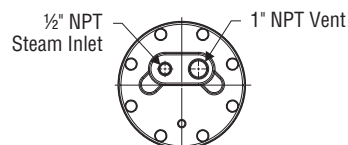
### Application

The FPS-11 is a small footprint, float activated pump that will transfer a variety of liquids by using a pressurized gas (air, steam, etc.) as the motive force instead of electricity. The volume of liquid pumped per cycle is 5.0 gallons.

- Heat Exchangers with modulating steam control valves.
- Remote installations – such as tracing, tank farms, etc.
- Systems with high back pressures.
- Hazardous or remote area where electricity is prohibited or unavailable.
- Acids or process fluids that may cause problems with conventional electric pumps.
- Sumps or submersible areas.

### Features and Benefits

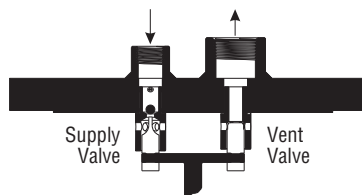
- Patented continuously compressed spring valve actuating mechanism.
- Rigid and stable internal mechanism is unaffected by turbulence.
- Single heavy-duty SST coil spring for superior performance and reliability.
- Optional ASME Code Stamped fabricated steel tank.
- Both valves are mounted on a single plate to eliminate the stiction common with gravity-assisted devices.
- All Stainless Steel internal valve actuating mechanism resists corrosion.
- Self-Centering supply and exhaust valves are lapped for tight shut-off.
- Negligible Net Positive Suction Head (NPSH) required.
- No adjustments, maintenance, or electricity required.
- No seals to leak or motors to burn out.
- Two (2) year warranty on pump and internal mechanism.
- Lifetime warranty against spring failure.



### Available Options

- Check valve material (Bronze or Stainless Steel).
- Gauge glass assembly (for viewing liquid level).
- Digital or mechanical cycle counter (for metering condensate flow).
- Pressure gauge.
- Custom fitted insulation jacket.
- Pressure reducing valve for pressurized gas.
- Stainless Steel or Lined tank (for corrosive service).
- Safety relief valve.
- Freeze protection drain valve.
- Contamination detection systems (Turbidity and/or Conductivity monitoring)
- Complete skid mounted unit, fully piped with receiver tank, pump(s), check valves, and other options.

### Supply and Vent Valve Arrangement



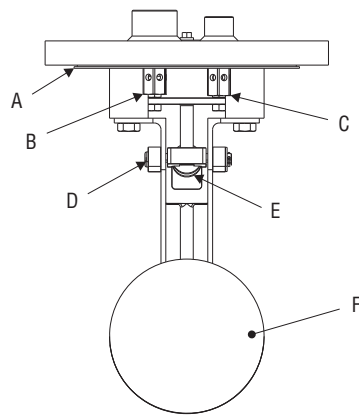
**150**  
psi  
Maximum  
(10.3 bar)

**Gestra® Pump • Non-Electric Pump**  
**GestraPump™**

**FPS-11**

**Available Sizes:** Up to 1" Inlet  
Up to 1" Outlet

Steam Pressure		Back Pressure		FPS-11 Capacity	
psig	barg	psig	barg	lb/hr	kg/hr
150	10.3	15	1	2,550	1,160
		40	2.8	2,400	1,090
		60	4.1	2,250	1,023
125	8.6	15	1	2,550	1,160
		40	2.8	2,350	1,065
		60	4.1	2,250	1,023
100	6.9	15	1	2,550	1,160
		40	2.8	2,350	1,065
		60	4.1	2,150	1,023
75	5.2	15	1	2,450	1,113
		40	2.8	2,350	1,065
		60	4.1	1,950	885
50	3.4	10	.7	2,450	1,113
		25	1.7	2,350	1,065
		40	2.8	1,950	885
25	1.7	5	.3	2,250	1,023
		10	.7	2,050	930
		15	1	1,950	885



Standard Spare Parts		
Item Number	Description	
A	Cover Gasket	FPS-017
B	Exhaust Valve Assembly	FPS-007
C	Supply Valve Assembly	FPS-006
D	Pin Assembly	FPS-010
E	Spring Assembly	FPS-008
F	Float Ball	FPS-311

**Capacity Chart**

The capacity of the FPS-11 is dependent upon the gas pressure used to pump the fluid vs. the back pressure in the return line. The capacity chart shows some typical supply and system back pressures for condensate. These capacities are based on the RK 16A check valve Cv and a minimum filling head of 12". Please consult Flowserve Gestra for liquids with a specific gravity less than 0.9.

**Operation**

**Filling** Liquid to be pumped enters the vessel through the inlet check valve, at which point the vent valve is open and the gas supply valve is closed. As the unit fills, the stainless steel ball float rises.

**Pumping** At the high trip point the mechanism snaps over center and the compressed coil spring closes the vent valve and opens the supply valve simultaneously. The gas pressure then pushes the liquid out through the outlet check valve. As the liquid level drops, the ball float drops. At the low trip point the spring mechanism again snaps over center, closing the gas supply valve and opening the vent valve. When pressure in the tank falls below inlet pressure, flow resumes through the inlet check valve and the pump is ready to repeat the cycle.

**Service Range**

Max P/T: **200 psig** (13.8 bar) at 392°F (200°C)

Please consult Flowserve Gestra for higher pressures and temperatures.

**Spring Options**

Various check valve spring cracking pressures as well as check valve types are available for special conditions. Please consult your local Flowserve Gestra representative for more details.

**Available End Connections**

1" NPT screwed inlet connections.

1" NPT screwed outlet connections.

ANSI 150RF flanged ends: 1" inlet, 1" outlet

Other connections are available upon request.

**How to Order**

Specify end connection size and type.

For Example: FPS-11 1" x 1" NPT

# Gestra® Pump • Non-Electric Pump

## GestraPump™

FPS-14

**200**  
psi  
Maximum  
(13.8 bar)

**Available Sizes:** Up to 3" Inlet  
Up to 2" Outlet

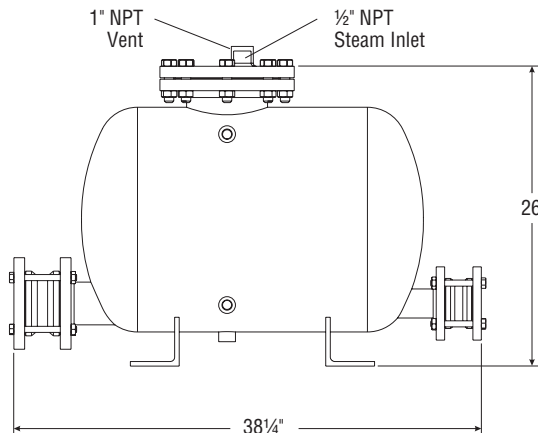
### Application

The FPS-14 is a float activated pump that will transfer a variety of liquids by using a pressurized gas (air, steam, etc.) as the motive force without the use of electricity. The volume of liquid pumped per cycle is 15 gallons.

- Heat Exchangers with modulating steam control valves.
- Remote installations – such as tracing, tank farms, etc.
- Systems with high back pressures.
- Hazardous or remote area where electricity is prohibited or unavailable.
- Acids or process fluids that may cause problems with conventional electric pumps.
- Sumps or submersible areas.

### Features and Benefits

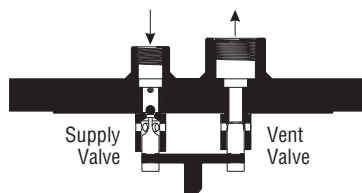
- Patented continuously compressed spring valve actuating mechanism.
- Rigid and stable internal mechanism is unaffected by turbulence.
- Single heavy duty SST coil spring for superior performance and reliability.
- ASME Code Stamped fabricated steel tank.
- Self-Centering Stainless Steel supply and exhaust valves are lapped for tight shut-off, and are mounted on a single plate to eliminate the stiction common with gravity-assisted devices.
- Lower horizontal profile allows for possible installation below heat exchangers and pumps at least 50% more liquid per cycle than vertical non-electric pumps, resulting in lower cycle rate and longer life.
- All SST internal valve actuating mechanism resists corrosion.
- Negligible Net Positive Suction Head (NPSH) required.
- No adjustments, maintenance, or electricity required.
- No seals to leak or motors to burn out.
- Two (2) year warranty on pump and internal mechanism.
- Lifetime warranty against spring failure.



### Available Options

- Check valve material (Bronze or Stainless Steel).
- Gauge glass assembly (for viewing liquid level).
- Digital or mechanical cycle counter (for metering condensate flow).
- Pressure gauge.
- Custom fitted insulation jacket.
- Pressure reducing valve for pressurized gas.
- Stainless Steel or Lined tank (for corrosive service).
- Safety relief valve.
- Freeze protection drain valve.
- Contamination detection systems (Turbidity and/or Conductivity monitoring)
- Complete skid mounted unit, fully piped with receiver tank, pump(s), check valves, and other options.

### Supply and Vent Valve Arrangement



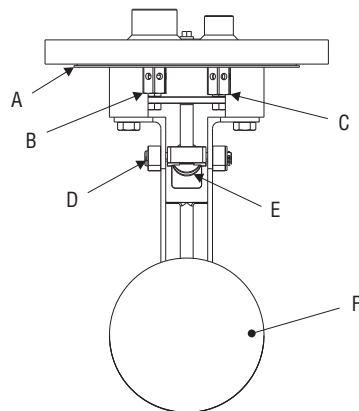
**200**  
psi  
Maximum  
(13.8 bar)

**Gestra® Pump • Non-Electric Pump**  
**GestraPump™**

**FPS-14**

**Available Sizes:** Up to 3" Inlet  
Up to 2" Outlet

Steam Pressure		Back Pressure		FPS-14 Capacity	
psig	barg	psig	barg	lb/hr	kg/hr
200	13.8	20	1.4	17,300	7,860
		40	2.8	15,200	6,910
		60	4.1	11,700	5,320
150	10.3	20	1.4	15,800	7,180
		40	2.8	13,900	6,320
		60	4.1	10,700	4,860
125	8.6	20	1.4	14,400	6,545
		40	2.8	12,500	5,680
		60	4.1	9,500	4,318
100	6.9	20	1.4	13,000	5,909
		40	2.8	11,100	5,045
		60	4.1	8,300	3,772
75	5.2	20	1.4	11,500	5,230
		40	2.8	9,400	4,273
		60	4.1	7,100	3,227
50	3.4	10	.7	11,100	5,045
		20	1.4	9,300	4,227
		30	2.1	8,000	3,636
25	1.7	5	.3	10,900	4,955
		10	.7	8,800	4,000
		15	1	6,900	3,136
15	1	3	.2	9,600	4,364
		7	.5	6,800	3,090



Standard Spare Parts		
Item Number	Description	
A	Cover Gasket	FPS-017
B	Exhaust Valve Assembly	FPS-007
C	Supply Valve Assembly	FPS-006
D	Pin Assembly	FPS-010
E	Spring Assembly	FPS-008
F	Float Ball	FPS-311

**Capacity Chart**

The capacity of the FPS-14 is dependent upon the gas pressure used to pump the fluid vs. the back pressure in the return line. The capacity chart shows some typical supply and system back pressures for condensate. These capacities are based on the RK 16A check valve Cv and a minimum filling head of 12". Please consult Flowserve Gestra for liquids with a specific gravity less than 0.9.

**Operation**

**Filling** Liquid to be pumped enters the vessel through the inlet check valve, at which point the vent valve is open and the gas supply valve is closed. As the unit fills the stainless steel ball float rises.

**Pumping** At the high trip point the mechanism snaps over center and the compressed coil spring closes the vent valve and opens the supply valve simultaneously. The gas pressure then pushes the liquid out through the outlet check valve. As the liquid level drops, the ball float drops. At the low trip point the spring mechanism again snaps over center, closing the gas supply valve and opening the vent valve. When pressure in the tank falls below inlet pressure, flow resumes through the inlet check valve and the pump is ready to repeat the cycle.

**Service Range**

MAWP: **200 psig** (13.8 bar) at 392°F (200°C)

Please consult Flowserve Gestra for higher pressures and temperatures.

**Spring Options**

Various check valve spring cracking pressures as well as check valve types are available for special conditions. Please consult your local Flowserve Gestra representative for more details.

**Available End Connections**

1"–3" NPT screwed inlet connections.

1"–2" NPT screwed outlet connections.

ANSI 150RF flanged ends: 3" inlet, 2" outlet

Other connections available upon request.

**How to Order**

Specify end connection size and type.

For Example: FPS-14 3" x 2" ANSI 150RF

## Gestra® Pump • Non-Electric Pump GestraPump™

FPS-24

**200**  
psi  
Maximum  
(10.3 bar)

**Available Sizes:** Up to 2" Inlet  
Up to 2" Outlet

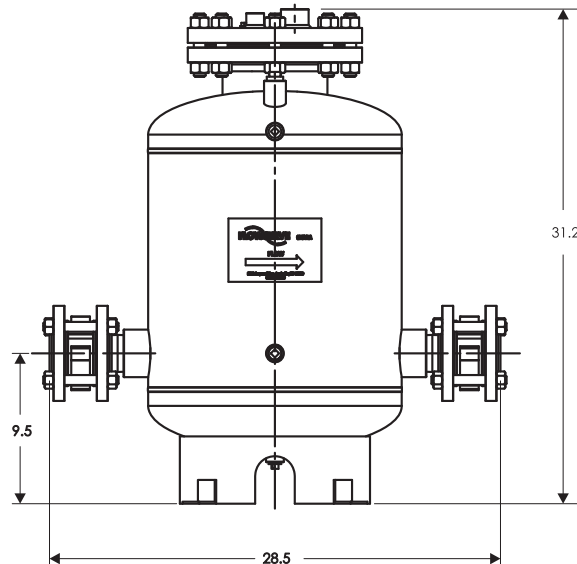
### Application

The FPS-24 is a float activated pump that will pump a variety of liquids by using a pressurized gas (air, steam, etc.) as the motive force without the use of electricity. The volume of liquid pumped per cycle is 7.0 gallons.

- Heat Exchangers with modulating steam control valves.
- Remote installations - such as tracing, tank farms, etc.
- Systems with high back pressures.
- Hazardous or remote area where electricity is prohibited or unavailable.
- Acids or process fluids that may cause problems with conventional electric pumps.
- Sumps or submersible areas.

### Features and Benefits

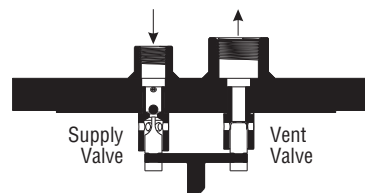
- Patented continuously compressed spring valve actuating mechanism.
- Rigid and stable internal mechanism is unaffected by turbulence.
- Single heavy duty SST coil spring for superior performance and reliability.
- ASME Code Stamped fabricated steel tank.
- Both valves are mounted on a single plate to eliminate the stiction due to gravity-assisted devices.
- All Stainless Steel internal valve actuating mechanism resists corrosion.
- Self-Centering supply and exhaust valves are lapped for tight shut-off.
- Negligible Net Positive Suction Head (NPSH) required.
- No adjustments, maintenance, or electricity required.
- No seals to leak or motors to burn out.
- Two (2) year warranty on pump and internal mechanism.
- Lifetime warranty against spring failure.
- Weight: 200 lb. (91 kgs).



### Available Options

- Check valve material (Bronze or Stainless Steel).
- Gauge glass assembly (for viewing liquid level).
- Digital or mechanical cycle counter (for metering condensate flow).
- Pressure gauge.
- Custom fitted insulation jacket.
- Pressure reducing valve for pressurized gas.
- Stainless Steel or Lined tank (for corrosive service).
- Safety relief valve.
- Freeze protection drain valve.
- Contamination detection systems (Turbidity and/or Conductivity monitoring).
- Complete skid mounted unit, fully piped with receiver tank, pump(s), check valves, and other options.

### Supply and Vent Valve Arrangement



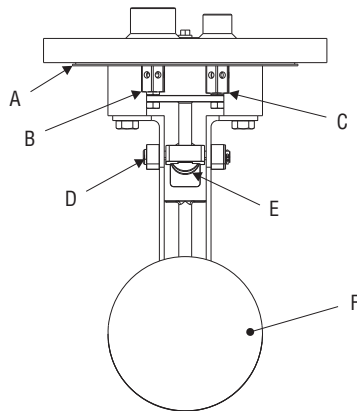
**200**  
psi  
Maximum  
(10.3 bar)

**Gestra® Pump • Non-Electric Pump**  
**GestraPump™**

**FPS-24**

**Available Sizes:** Up to 2" Inlet  
Up to 2" Outlet

Steam Pressure		Back Pressure		FPS-24 Capacity			
				2"		1"	
psig	barg	psig	barg	lb/h	kg/h	lb/h	kg/h
150	10.3	15	1.0	6,800	3,091	2,700	1,227
		40	2.8	6,500	2,955	2,500	1,136
		60	4.1	6,200	2,818	2,300	1,045
125	8.6	15	1.0	6,700	3,045	2,600	1,182
		40	2.8	6,300	2,864	2,400	1,091
		60	4.1	6,000	2,727	2,300	1,045
100	6.9	15	1.0	6,600	3,000	2,600	1,182
		40	2.8	6,100	2,773	2,400	1,091
		60	4.1	5,800	2,636	2,200	1,000
75	5.2	15	1.0	6,600	3,000	2,500	1,136
		40	2.8	5,800	2,636	2,200	1,000
		60	4.1	5,000	2,273	2,000	909
50	3.4	15	1.0	6,400	2,909	2,400	1,091
		25	1.7	5,800	2,636	2,300	1,045
		40	2.8	4,800	2,182	2,000	909
25	1.7	5	0.3	6,100	2,773	2,300	1,045
		10	0.7	5,600	2,545	2,100	955
		15	1.0	5,100	2,318	2,000	909
15	1.0	3	0.2	5,200	2,364	2,100	955
		7	0.5	4,200	1,909	1,900	864



Standard Spare Parts		
Item Number	Description	
A	Cover Gasket	FPS-017
B	Exhaust Valve Assembly	FPS-007
C	Supply Valve Assembly	FPS-006
D	Pin Assembly	FPS-010
E	Spring Assembly	FPS-008
F	Float Ball	FPS-311

**Capacity Chart**

The capacity of the FPS-24 is dependent upon the gas pressure used to pump the fluid and the back pressure in the return line. The capacity chart shows some typical supply and system back pressures. These capacities are based on the RK 16A check valve Cv and a minimum filling head of 12". For liquids with a Specific Gravity less than 0.9, consult Flowserve Gestra.

**Operation**

**Filling** Liquid to be pumped enters the vessel through the inlet check valve, at which point the vent valve is open and the gas supply valve is closed. As the unit fills, the stainless steel ball float rises.

**Pumping** At the high trip point the mechanism snaps over center and the compressed coil spring closes the vent valve and opens the supply valve simultaneously. The gas pressure then pushes the liquid out through the outlet check valve. As the liquid level drops, the ball float drops. At the low trip point the spring mechanism again snaps over center, closing the gas supply valve and opening the vent valve. When pressure in the tank falls below inlet pressure, flow resumes through the inlet check valve and the pump is ready to repeat the cycle.

**Service Range**

MAWP: **200 psig** (13.8 bar) at 392°F (200°C)

Please consult Flowserve Gestra for higher pressures and temperatures.

**Spring Options**

Various check valve spring cracking pressures as well as check valve types are available for special conditions. Please consult your local Flowserve Gestra representative for more details.

**Available End Connections**

1"-2" NPT screwed inlet connections.

1"-2" NPT screwed outlet connections.

ANSI 150RF flanged ends: 2" inlet, 2" outlet

Other connections available upon request.

**How to Order**

Specify end connection size and type.

For Example: FPS-24 2" x 2" NPT

## Gestra® Pump • Non-Electric Pump GestraPump™

FPS-33L

**150**  
psi  
Maximum  
(10.3 bar)

**Available Sizes:** Up to 4" Inlet  
Up to 4" Outlet

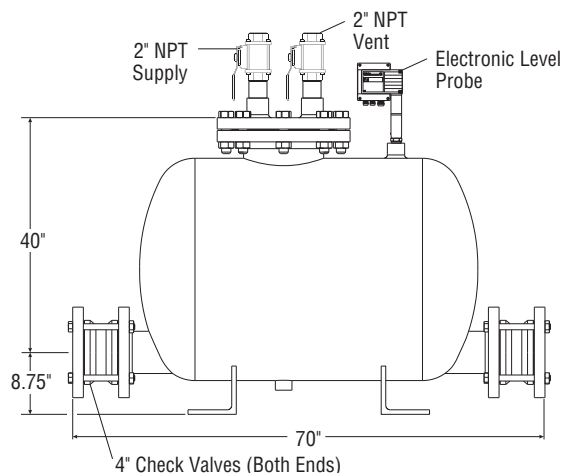
### Application

The FPS-33L uses Flowserve Gestra self-contained, self-monitoring level conductivity probes with internal setpoints to actuate steam and vent ball valves to pump a variety of liquids using a pressurized gas (air, steam, etc.) as the motive force instead of electrical impellers. No outboard electronics are required. The volume of liquid pumped per cycle is 105 gallons.

- Large heat exchangers with modulating steam control valves.
- Remote installations – such as tracing, tank farms, etc.
- Low pressure steam systems.
- Systems with high back pressures.
- Acids or fluids that may cause problems with conventional electric pumps.
- Slurries and viscous liquids that may cause clogging problems in conventional pumps.

### Features and Benefits

- Uses Gestra Level Control Probe NRG16-1 with latching relay assembly, using self-contained wiring, and ball valves designed specifically for boiler water and condensate service.
- Redundancy Level Controls available for fail-safe design ensures that pump will not pressurize condensate return system or cause back-up of condensate.
- Electrical wiring is to the probe heads, which distributes all appropriate electrical signals.
- Modular design allows for in-line troubleshooting and repair without the need for disassembly.
- ASME Code Stamped fabricated steel tank.
- Negligible Net Positive Suction Head (NPSH) required.
- Two (2) year warranty on pump, level controls and valves.
- Weight: 900 lb. (409 kgs).



### Available Options

- Check valve material (Bronze or Stainless Steel).
- Gauge glass assembly (for viewing liquid level).
- Digital or mechanical cycle counter (for metering condensate flow).
- Pressure gauge.
- Custom fitted insulation jacket.
- Pressure reducing valve for pressurized gas.
- Stainless Steel or Lined tank (for corrosive service).
- Safety relief valve.
- Freeze protection drain valve.
- Contamination detection systems (Turbidity and/or Conductivity monitoring)
- Complete skid mounted unit, fully piped with receiver tank, pump(s), check valves, and other options.

**150**  
psi  
Maximum  
(10.3 bar)

**Gestra® Pump • Non-Electric Pump**  
**GestraPump™**

**FPS-33L**

**Available Sizes:** Up to 4" Inlet  
Up to 4" Outlet

Steam Pressure		Back Pressure		FPS-33L Capacity	
psig	barg	psig	barg	lb/hr	kg/hr
150	10.3	15	1	<b>48,500</b>	22,045
		40	2.8	<b>44,200</b>	20,090
		60	4.1	<b>39,900</b>	18,136
		80	5.5	<b>35,000</b>	15,909
		100	6.9	<b>30,000</b>	13,636
125	8.6	15	1	<b>48,200</b>	21,909
		40	2.8	<b>43,600</b>	19,818
		60	4.1	<b>38,500</b>	17,500
		80	5.5	<b>32,900</b>	14,955
100	6.9	15	1	<b>47,500</b>	21,590
		40	2.8	<b>42,100</b>	19,136
		60	4.1	<b>35,800</b>	16,273
		80	5.5	<b>27,900</b>	12,682
75	5.2	15	1	<b>46,700</b>	21,227
		40	2.8	<b>39,500</b>	17,955
		60	4.1	<b>30,500</b>	13,864
50	3.4	10	0.7	<b>46,500</b>	21,136
		25	1.7	<b>40,100</b>	18,227
		40	2.8	<b>30,200</b>	13,727
25	1.7	5	.3	<b>45,700</b>	20,773
		10	.7	<b>40,300</b>	18,318
		15	1	<b>34,600</b>	15,727

Spare parts available upon request.

**Capacity Chart**

The capacity of the FPS-33L is dependent upon the gas pressure used as a motive force vs. the back pressure in the return line. The capacity chart shows some typical supply and system back pressures. These capacities are based on the CB 26A check valve Cv and a minimum filling head of 18". Please consult Flowserve Gestra for liquids with a Specific Gravity less than 0.9.

**Operation**

The FPS-33L level controlled pump consists of a tank, inlet and outlet manual check valves (Flowserve Gestra RK series) and pneumatically actuated motive and vent ball valves with electric solenoid valves, controlled by the level control system. The gas supply valve is supplied standard as fail-closed, while the vent valve is supplied standard as fail-open.

**Filling** The vent valve is open, equalizing pressure between the tank chamber and inlet piping. The liquid to be pumped enters the vessel through the inlet check valve. The gas supply valve is closed at this point.

**Pumping** When the liquids reaches the high level point, the vent valve closes and the gas supply valve opens simultaneously. When the tank pressure exceeds the outlet line pressure, the gas pressure pumps the liquid out through the outlet check valve. When liquid reaches the low-level point, the gas supply valve recloses and the vent valve reopens. When the pressure in the tank falls below the inlet pressure, flow resumes through the inlet check valve to repeat the process.

**Service Range**

MAWP: **150 psig** (10.3 bar) at 450°F (232°C)

Please consult Flowserve Gestra for higher pressures and temperatures.

**Available End Connections**

ANSI 150RF flanged ends: 4" inlet, 4" outlet

Other connections available upon request.

**How to Order**

Specify end connection size and type.

For Example: FPS-33L 4" x 4" ANSI 150RF

**NOTE:** If Ex area enclosures are required, be sure to state the Class, Division, and Groups for the area.



## Gestra® Pump • Non-Electric Pump GestraPump™ Simplex and Duplex

## Skid Packages

**200**  
psi  
Maximum  
(13.8 bar)

**Available Sizes:** Up to 4" Inlet  
Up to 4" Outlet

### Application

The GestraPump™ is a float activated pump that will transfer a variety of liquids by using a pressurized gas (air, steam, etc.) as the motive force without the use of electricity.

The receiver tank is designed to provide separation between condensate and steam as well as act as a reservoir to store condensate during the pumping cycle.

- Heat Exchangers with modulating steam control valves.
- Remote installations – such as tracing, tank farms, etc.
- Hazardous or remote areas where electricity is prohibited or unavailable.
- Low pressure steam systems.
- Systems with high back pressures.
- Acids or process fluids that may cause problems with conventional electric pumps.
- Slurries and viscous liquids that may cause clogging problems in conventional pumps.
- Multiple pumps may be utilized to provide larger flow rates.

### Package Includes

- GestraPump™ FPS non-electric pump(s) with Gestra RK series check valves.
- Skid-mounted, fabricated steel receiver tank (Atmospheric or ASME Code Stamped designs available).
- All process interconnecting piping between the receiver tank and the pump(s), complete with isolation valve(s) on the pump inlet(s).

*Simplex Pumping Package*



*Duplex Pumping Package*



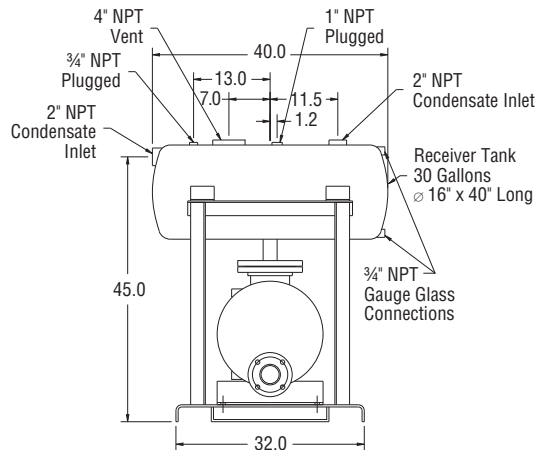
**200**  
psi  
Maximum  
(13.8 bar)

## Gestra® Pump • Non-Electric Pump GestraPump™ Simplex and Duplex

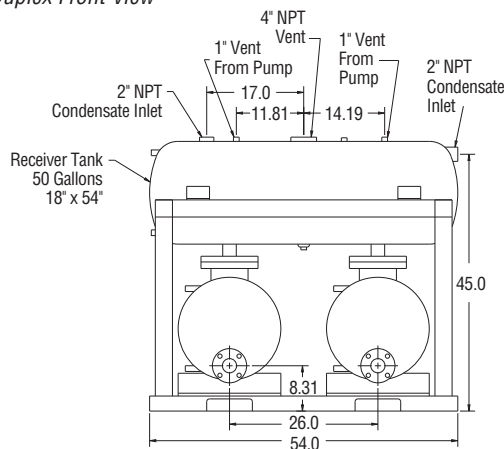
## Skid Packages

**Available Sizes:** Up to 4" Inlet  
Up to 4" Outlet

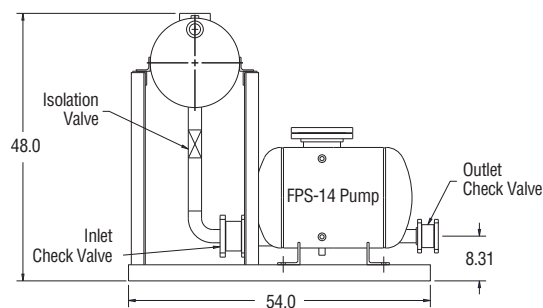
*Simplex Front View*



*Duplex Front View*



*Duplex/Simplex Side View*



### Operation

**Filling** Condensate enters the top of the receiver tank, where flash steam is separated and vented, or used for a low pressure steam supply. The liquid condensate flows to the GestraPump.

**Pumping** When the internal float mechanism trips over center, the gas supply valve is opened and the vent valve is closed simultaneously. The tank pressure now closes the inlet check valve and pumps the fluid through the outlet check valve. Once the liquid level drops in the pump tank, the mechanism releases the gas valve and opens the vent valve simultaneously. When the pressure inside the pump tank drops to below that of the inlet piping, liquid begins to flow through the inlet check valve to repeat the cycle.

The pumps will work independently of each other if more than one is installed on the skid package. For a more detailed explanation of the FPS-14 please see the data sheet.

Please consult your local Flowserve Gestra representative for more detailed dimensional drawings for the Pump Packages or the GestraPump, or to provide a specific quotation for your application.

## GESTRA Steam Systems

Condensate Collector **V20.8/K**, PN 40, CL 300, DN 15-25  
 Steam Manifold **V20.8**, PN 40, CL 300, DN 15-25

Product Range A1

**V20.8/K**  
**V20.8**

### Description

#### V 20.8/K

Compact-type condensate collector, vertical design, with internal immersion tube, lateral connections and integral stuffing box type shut-off valves for any kind of pipe connection.

#### V 20.8

Steam manifold with lateral connections and integral stuffing box type shut-off valves for any kind of pipe connection.

#### Lateral connections:

DN 15, DN 20, DN 25.

#### Main connection:

DN 40

#### End connections:

Butt-weld ends,  
 Socket-weld ends,  
 Flanged EN 1092, PN 40,  
 Flanged ASME Class 150 RF

Flanged ASME Class 300 RF

### Function

#### Condensate collector V20.8/K

Condensate flows through the lateral connections into the manifold. The condensate is collected between the manifold and the concentrically arranged immersion tube, thereby creating a water pocket. The space above the water pocket acts as a dampening cushion consisting of flash steam. This steam cushion effectively prevents water hammer. The condensate flowing into the unit will be forced into the higher condensate collecting line as a function of its service pressure (differential pressure). Each lateral connection can be isolated by means of a stuffing box type shut-off valve.

#### Steam manifold V20.8

Steam flows through the main pipe connection at the front of the steam manifold. It passes through the lateral connections and flows to the consumers. Each lateral connection can be isolated by means of a stuffing box type shut-off valve.

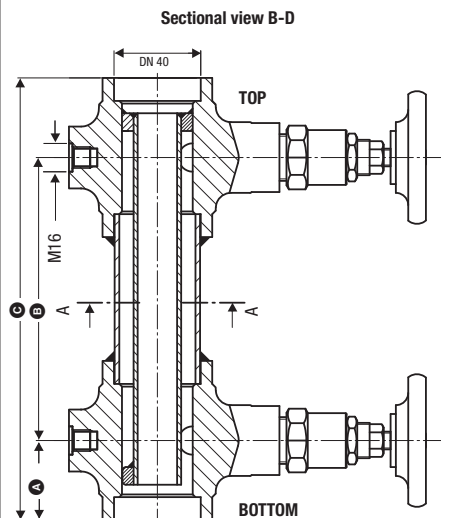
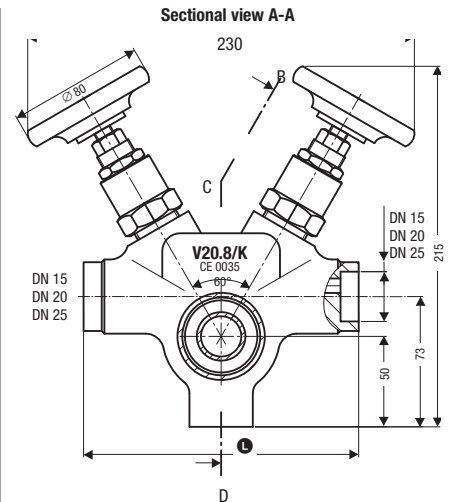
### Dimensions and Weights

Flanges EN 1092-1 PN 40							
N° of connections right/left	A	B	C	L			Weight [kg]
				DN 15	DN 20	DN 25	
1/1	92	160	184	232	236	236	9
2/2	92	160	344	232	236	236	17
3/3	92	160	504	232	236	236	25
4/4	92	160	664	232	236	236	34
5/5	92	160	824	232	236	236	43
6/6	92	160	984	232	236	236	51

Flanges B16.5 Class 150							
N° of connections right/left	A	B	C	L			Weight [kg]
				DN 15	DN 20	DN 25	
1/1	109	160	218	252	260	268	9
2/2	109	160	378	252	260	268	17
3/3	109	160	538	252	260	268	25
4/4	109	160	698	252	260	268	34
5/5	109	160	858	252	260	268	43
6/6	109	160	1018	252	260	268	51

Flanges B16.5 Class 300							
N° of connections right/left	A	B	C	L			Weight [kg]
				DN 15	DN 20	DN 25	
1/1	109	160	230	260	270	280	10
2/2	109	160	390	260	270	280	19
3/3	109	160	550	260	270	280	28
4/4	109	160	710	260	270	280	38
5/5	109	160	870	260	270	280	48
6/6	109	160	1030	260	270	280	57

Butt-weld ends DIN 3239-1					
N° of connections right/left	A	B	C	L	Weight [kg]
1/1	45	160	90	152	4
2/2	45	160	250	152	8
3/3	45	160	410	152	12
4/4	45	160	570	152	16
5/5	45	160	730	152	20
6/6	45	160	890	152	24



Condensate collector V20.8/K  
 Socket-weld end DN 40, connections DN 20

Condensate Collector **V20.8/K**,  
 PN 40, CL 300, DN 15-25  
 Steam Manifold **V20.8**,  
 PN 40, CL 300, DN 15-25

**Order & Enquiry Specifications**

GESTA Condensate Collector  
 with immersion tube and stuffing box type shut-off valves.  
 Fixing holes M16  
 Insulating jacket for subsequent installation (optional).

**Type: V 20.8/K**

Connection:..... Lateral connections (can be shut-off)  
 Size: DN 15 / DN 20 / DN 25  
 Connection TOP: Socket-weld end / Butt-weld end  
 Connection BOTTOM: Socket-weld end / Butt-weld end  
 Pressure rating: PN 40 / CL 150 RF / CL 300 RF  
 Insulating jacket: Yes / No  
 Certification: Test certificate to EN 10204, 3.1

GESTA Steam Manifold  
 with stuffing box type shut-off valves.

Fixing holes M16  
 Insulating jacket for subsequent installation (optional).

**Type: V 20.8**

Connection:..... Lateral connections (can be shut-off)  
 Size: DN 15 / DN 20 / DN 25  
 Connection TOP: Socket-weld end / Butt-weld end  
 Connection BOTTOM: Socket-weld end / Butt-weld end  
 Pressure rating: PN 40 / CL 150 RF / CL 300 RF  
 Insulating jacket: Yes / No  
 Certification: Test certificate to EN 10204, 3.1

**When ordering please state**

Steam pressure, back pressure, condensate flowrate, type and size of pipe connection, place of installation, details of application or type of steam consumption.

The following test certificates can be issued on request at extra cost:

In accordance with EN 10204/3.1. All inspection requirements have to be stated with the order. After supply of the equipment certification can no longer be established. Charges and extent of the above mentioned certificates as well as the different test confirmed therein are listed in our price list "Test and Inspection Charges for Standard Equipment". For other tests and inspections than those listed above please consult us.

**PED (Pressure Equipment Directive)**

The equipment fulfills the requirements of the Pressure Equipment Directive (PED) 97/23/EC.

V20.8/K and V20.8 can be used with fluids of group 2.

With CE marking, except equipment that is excluded from the scope of this Directive as stated in section 3.3 of the PED.

**ATEX (Atmosphère Explosible)**

The equipment does not have its own potential source of ignition and is therefore excluded from the scope of the Directive 94/9/EC. Applicable in Ex zones 0, 1, 2, 20, 21, 22 (1999/92/EC). The equipment is without Ex marking.

Supply in accordance with our general terms of business.

**Pressure/Temperature Ratings and Materials**

Flanges PN 40 EN 1092-1 / Butt-weld ends DIN 3239-1 / 1.0460 (P250GH / C 22.8)							
Service pressure	PMA	[bar]	40.0	34.7	28.4	24.0	23.1
Inlet temperature	TMA	[°C]	20	150	250	350	400

Flanges B16.5 Class 300, socket-weld ends B16.25 Sched. 40 / 1.0460 (P250GH / A105)							
Service pressure	PMA	[bar]	51.0	45.0	41.0	37.0	34.0
Inlet temperature	TMA	[°C]	20	150	250	350	400

**Materials**

V20.8 V20.8/K	EN	ASTM
Body	P250GH (1.0460)	A105
Immersion tube (V20.8/K)	1.0305	A106*
Hand wheel	Sheet steel	Sheet steel
Thrust ring for stuffing box	1.0401	A 576-1015*
Gasket	1.0330	A109*
Spindle	1.4104	AISI 430 F*
Cone	1.4034	Chromium steel (13 %)
Cone seat	1.4104	AISI 430 F*
Collar	1.0501	A 576-1035*
Wiper ring	Novapress	Novapress
Packing	Graphite	Graphite
Lock nut	1.0501	A 576-1035*

\*) Physical and chemical properties comply with DIN grade. ASTM nearest equivalent grade is stated for guidance only.

**GESTRA AG**

P. O. Box 10 54 60, D-28054 Bremen  
 Münchener Str. 77, D-28215 Bremen  
 Telephone +49 (0) 421 35 03 -0, Fax +49 (0) 421 35 03-393  
 E-Mail gestra.ag@flowserve.com, Internet www.gestra.de



GESTRA

## Gestra® Condensate Manifolds

## FMAVC

### Application

The FMAVC manifolds are designed for vertical installation to provide up to 16 connection points. The compact design allows for easy installation, operation, and maintenance while maintaining a flexibility for fast installation. Typical installations include steam tracing, light process, separators, and main steam drips.

### Features and Benefits

- Available in Carbon Steel or Stainless Steel materials.
- Can be shipped pre-assembled with steam traps.
- Available in virtually any header size.
- Custom configurations can be easily provided.

### Available Designs

The standard design has either 4, 6, 8, 10, 12, or 16 ½" NPT connections.

### Construction Features

Standard construction shall consist of ASTM A106 Gr. B carbon steel 3" Sch. 80 pipe with ½" ANSI Class 3000 connections. Each assembly shall have a ¾" drain connection and 2" condensate discharge connection. Each assembly will have an internal siphon tube to maintain a water seal and ensure even temperature distribution. Mounting brackets are provided for ease of installation. Welding is to be performed in accordance with the current version of Section IX of the ASME Boiler and Pressure Vessel Code. Assemblies shall be tested at 1.5 times design pressure, sandblasted and painted with heat resistant paint.

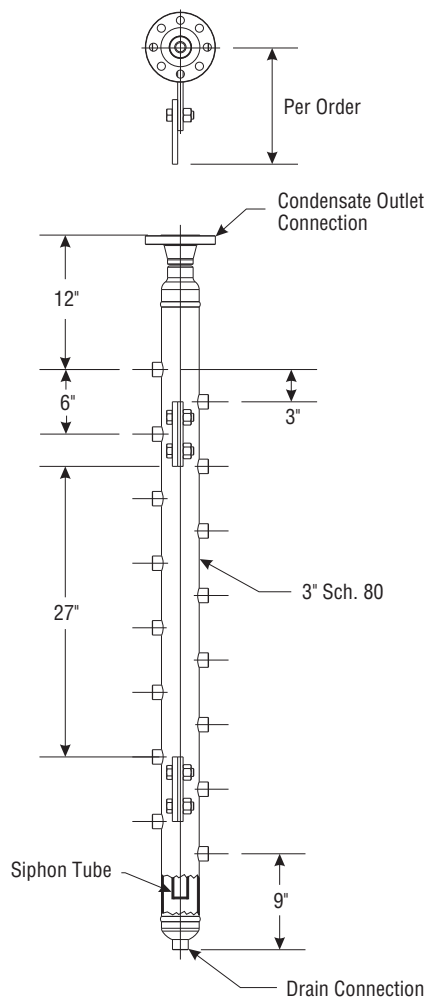
### Connections

- Condensate Outlet: 1"-2" BW, SW, Flanged
- Condensate Inlets: ½", ¾" NPT, SW

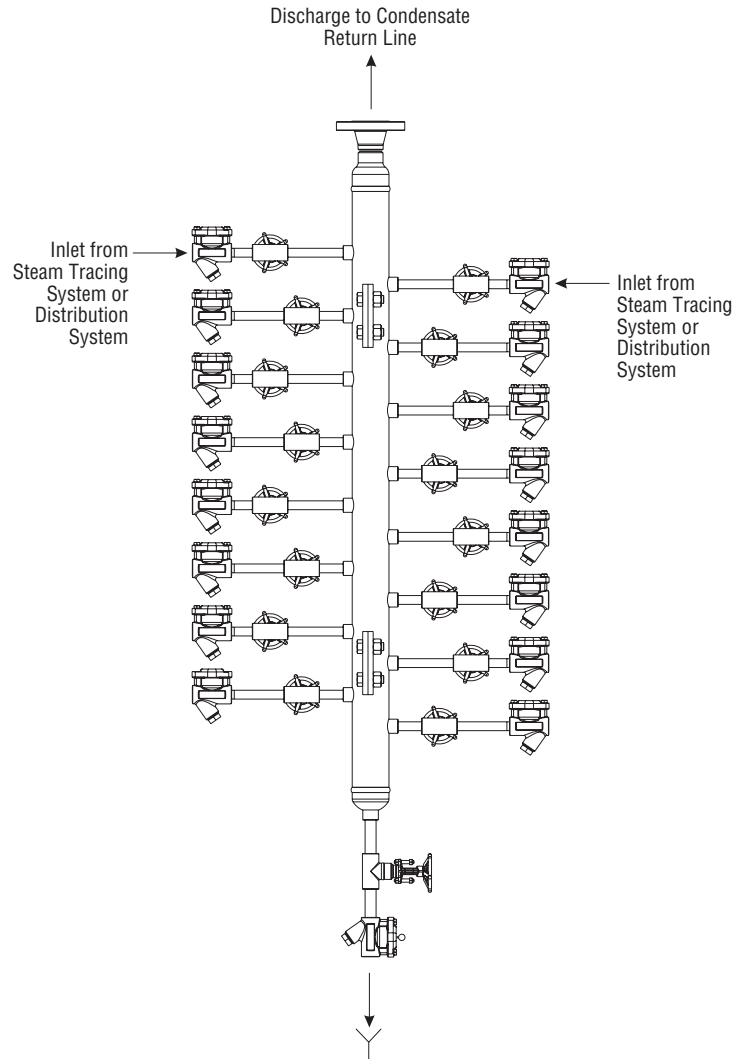
### How to Order

Specify type.

For Example: FMA 10 VC ½" NPT



Model	FMA
PMA	800 psig at 500 55 bar at 260
Hydrotest Pressure	1,200 psig 82 barg



### Installation

The manifold is to be installed vertically with the discharge connection at the top as shown. Mounting of the manifold is accomplished using the brackets provided with the manifold (shown with brackets for welding to a post or beam). When using the manifold in an outdoor installation it is recommended to install the AK 45 drain trap (shown above) to the drain connection to provide automatic drainage of the system when the pressure is below **12 psi**. Steam traps, Isolation valves, and other accessories can be attached on up to 3 sides at the connections provided.

### Options

Each manifold can be supplied with many different styles of isolation valves, steam traps, trap test stations and other equipment as a factory assembled unit. For additional mounting arrangements or materials please consult Flowserve Gestra.

**NOTE:** Local regulations may restrict the use of this product to below the stated pressure and temperature.

# Gestra® Steam Manifolds

# FMAVS

### Application

The FMAVS manifolds are designed for vertical installation to provide up to 16 connection points. The compact design allows for easy installation, operation, and maintenance while maintaining a flexibility for fast installation. Typical installations include steam tracing, light process, separators, and main steam drips.

### Features and Benefits

- Available in Carbon Steel or Stainless Steel materials.
- Available in virtually any header size.
- Custom configurations can be easily provided.

### Available Designs

The standard design has either 4, 6, 8, 10, 12, or 16 ½" NPT connections.

### Construction Features

Standard construction shall consist of ASTM A106 Gr. B carbon steel 3" Sch. 80 pipe with ½" ANSI Class 3000 connections. Each assembly shall have a ¾" drain connection and 2" steam inlet connection. Mounting brackets are provided for ease of installation. Welding is to be performed in accordance with the current version of Section IX of the ASME Boiler and Pressure Vessel Code. Assemblies shall be tested at 1.5 times design pressure, sandblasted and painted with heat resistant paint.

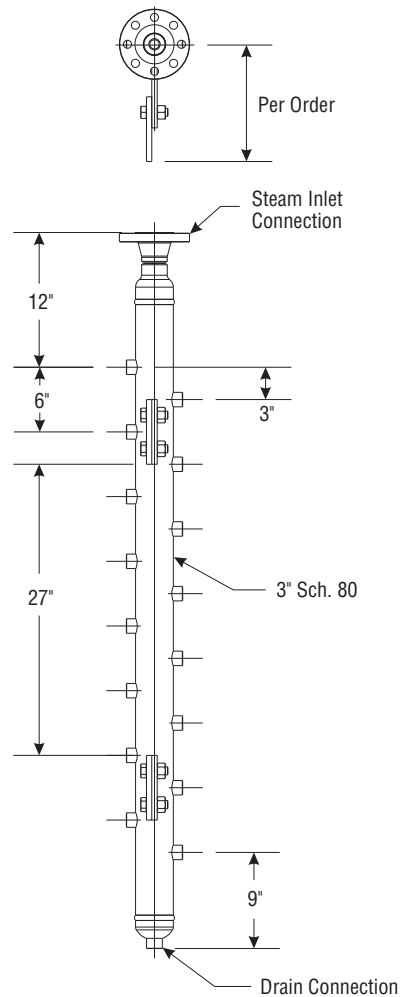
### Connections

- Steam Outlet: ½", ¾" NPT, SW
- Steam Inlets: 1"-2" BW, SW, Flanged

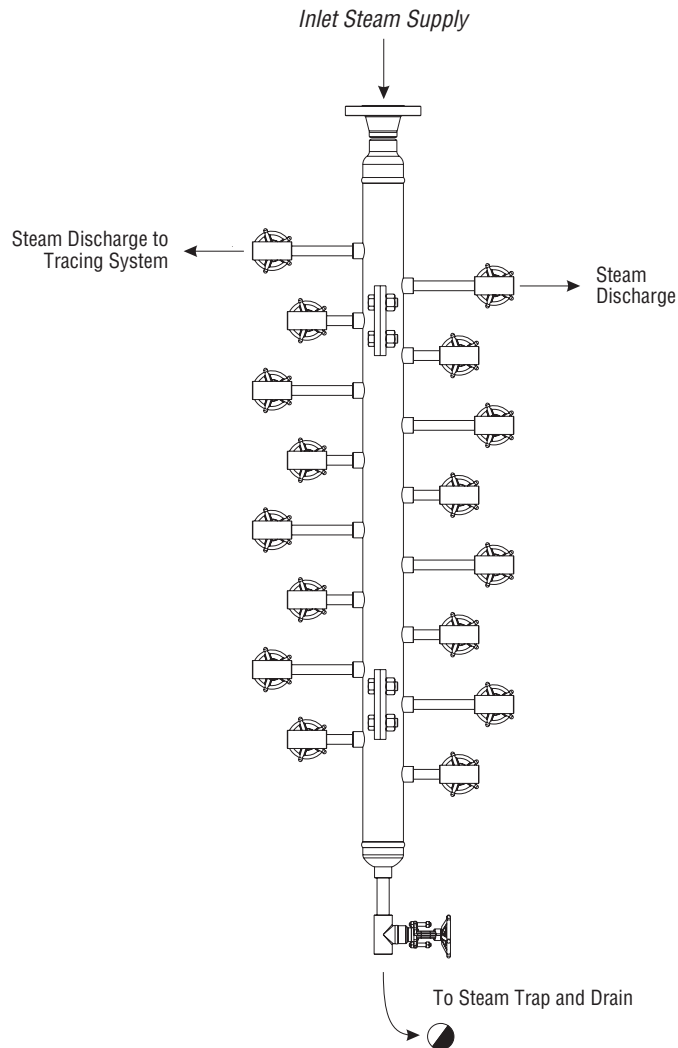
### How to Order

Specify type.

For Example: FMA 10 VS ½" NPT



Model	FMA
PMA	800 psig at 500 55 bar at 260
Hydrotest Pressure	1,200 psig 82 barg



### Installation

The manifold is to be installed vertically with the inlet connection at the top as shown. Mounting of the manifold is accomplished using the brackets provided with the manifold (shown with brackets for welding to a post or beam). When using the manifold in an outdoor installation, it is recommended to install the AK 45 drain trap (shown above) to the drain connection to provide automatic drainage of the system when the pressure is below **12 psi**. Isolation valves, and other accessories can be attached on up to 3 sides at the connections provided.

### Options

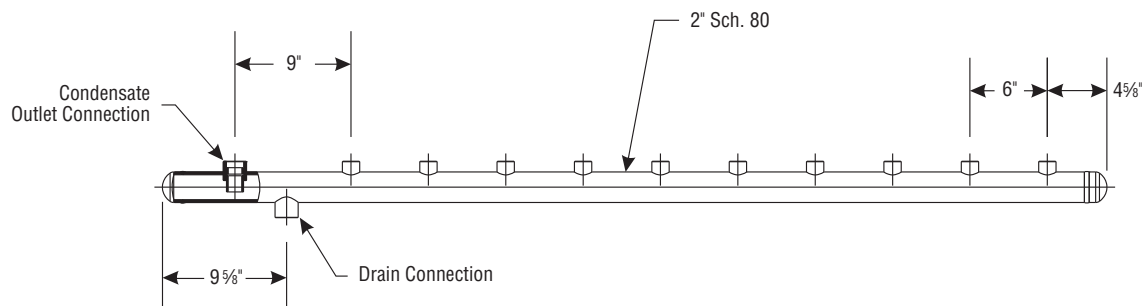
Each manifold can be supplied with many different styles of isolation valves and other equipment as a factory assembled unit. For additional mounting arrangements or materials please consult Flowserve Gestra.

**NOTE:** Local regulations may restrict the use of this product to below the stated pressure and temperature.



## Gestra® Condensate Manifolds

## FMAHC



Model	FMA
PMA	<b>800 psig at 500</b> 55 bar at 260
Hydrotest Pressure	<b>1,200 psig</b> 82 barg

### Application

The FMAHC manifolds are designed for vertical installation to provide up to 16 connection points. The compact design allows for easy installation, operation, and maintenance while maintaining a flexibility for fast installation. Typical installations include steam tracing, light process, separators, and main steam drips.

### Features and Benefits

- Available in Carbon Steel or Stainless Steel materials.
- Can be shipped pre-assembled with steam traps.
- Available in virtually any header size.
- Custom configurations can be easily provided.

### Available Designs

The standard design has either 4, 6, 8, 10, 12, or 16 ½" NPT connections.

### Construction Features

Standard construction shall consist of ASTM A106 Gr. B carbon steel 2" Sch. 80 pipe with ½" ANSI Class 3000 connections. Each assembly shall have a ¾" drain connection and 1" condensate discharge connection. Mounting brackets are provided for ease of installation. Welding is to be performed in accordance with the current version of Section IX of the ASME Boiler and Pressure Vessel Code. Assemblies shall be tested at 1.5 times design pressure, sandblasted and painted with heat resistant paint.

### Connections

- Condensate Outlet: 1" NPT, SW
- Condensate Inlets: ½", ¾" NPT, SW

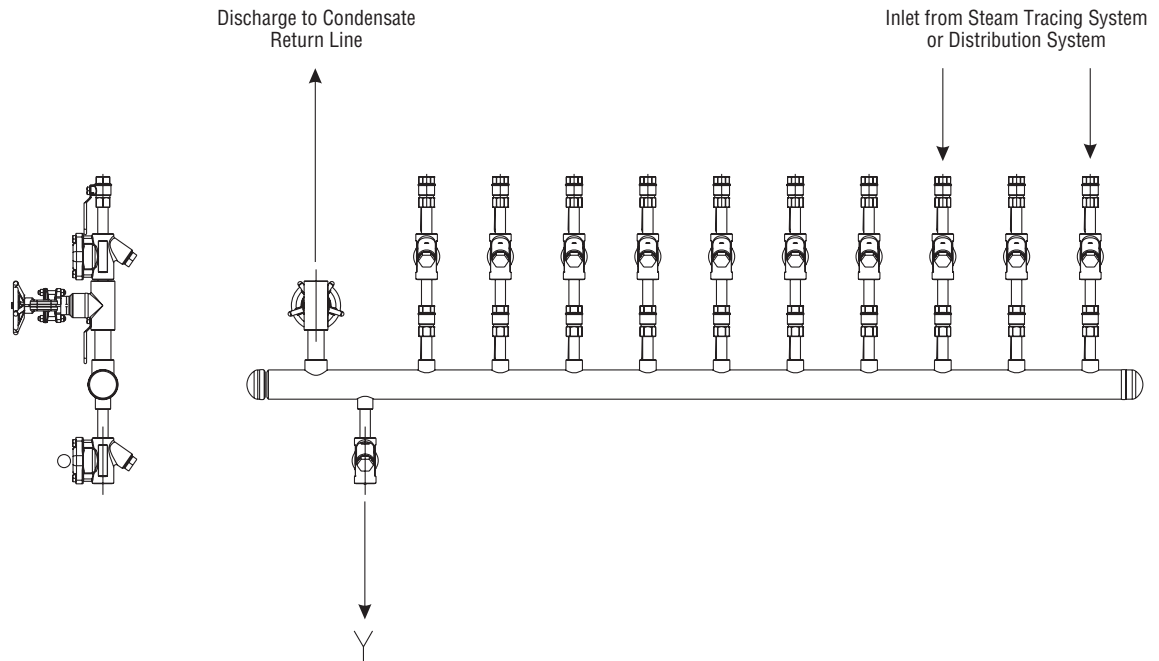
### How to Order

Specify type.

For Example: FMA 10 HC ½" NPT

## Gestra® Condensate Manifolds

FMAHC



### Installation

The manifold is to be installed horizontally with the inlet connection at the top as shown. Mounting of the manifold is accomplished using the brackets provided with the manifold. When using the manifold in an outdoor installation, it is recommended to install the AK 45 drain trap (shown above) to the drain connection to provide automatic drainage of the system when the pressure is removed. Isolation valves, and other accessories can be attached on up to 3 sides at the connections provided.

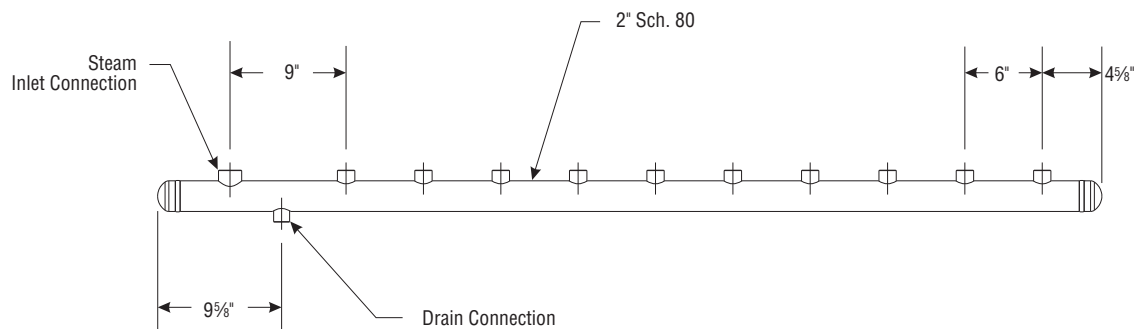
### Options

Each manifold can be supplied with many different styles of isolation valves and other equipment as a factory assembled unit. For additional mounting arrangements or materials please consult Flowserve Gestra.

**NOTE:** Local regulations may restrict the use of this product to below the stated pressure and temperature.

## Gestra® Steam Manifolds

## FMAHS



Model	FMA
PMA	800 psig at 500 55 bar at 260
Hydrotest Pressure	1,200 psig 82 barg

### Application

The FMAHS manifolds are designed for vertical installation to provide up to 16 connection points. The compact design allows for easy installation, operation, and maintenance while maintaining a flexibility for fast installation. Typical installations include steam tracing, light process, separators, and main steam drips.

### Features and Benefits

- Available in Carbon Steel or Stainless Steel materials.
- Available in virtually any header size.
- Custom configurations can be easily provided.

### Available Designs

The standard design has either 4, 6, 8, 10, 12, or 16 ½" NPT connections.

### Construction Features

Standard construction shall consist of ASTM A106 Gr. B carbon steel 2" Sch. 80 pipe with ½" ANSI Class 3000 connections. Each assembly shall have a ¾" drain connection and 1½" steam inlet connection. Mounting brackets are provided for ease of installation. Welding is to be performed in accordance with the current version of Section IX of the ASME Boiler and Pressure Vessel Code. Assemblies shall be tested at 1.5 times design pressure, sandblasted and painted with heat resistant paint.

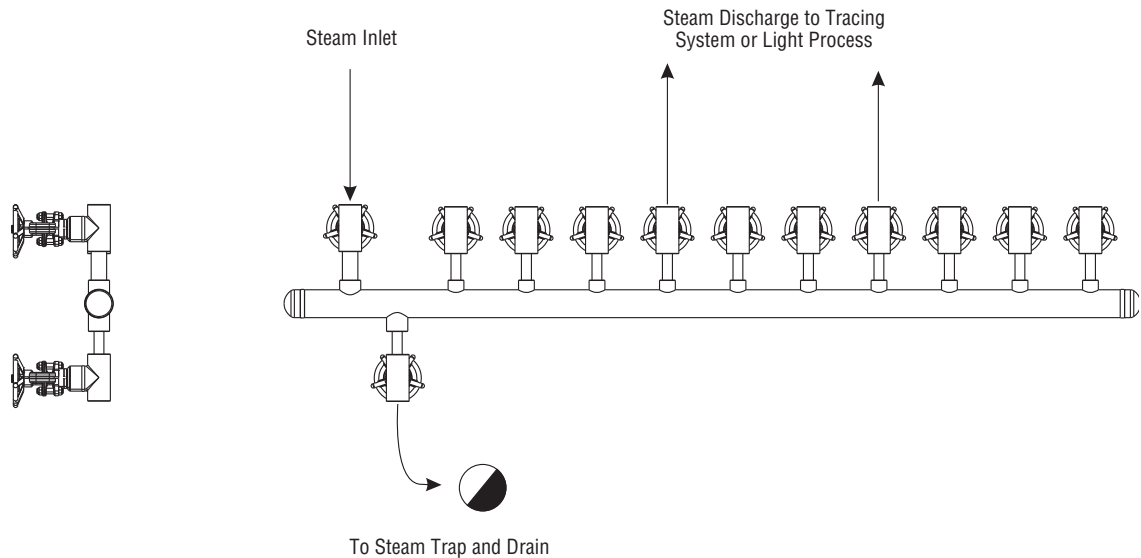
### Connections

- Steam Inlet: 1½" NPT, SW
- Steam Outlets: ½", ¾" NPT, SW

### How to Order

Specify type.

For Example: FMA 10 HC ½" NPT



### Installation

The manifold is to be installed horizontally with the inlet connection at the top as shown. Mounting of the manifold is accomplished using the brackets provided with the manifold. When using the manifold in an outdoor installation, it is recommended to install the AK 45 drain trap (shown above) to the drain connection to provide automatic drainage of the system when the pressure is removed. Isolation valves, and other accessories can be attached on up to 3 sides at the connections provided.

### Options

Each manifold can be supplied with many different styles of isolation valves and other equipment as a factory assembled unit. For additional mounting arrangements or materials please consult Flowserve Gestra.

**NOTE:** Local regulations may restrict the use of this product to below the stated pressure and temperature.

## Gestra® Engineering Data

### Conversion Formulas

#### Flow of water through pipe in feet/second

$$V = C \sqrt{\frac{hD}{L+54D}}$$

V = approximate mean velocity in feet per second  
 C = coefficient from the accompanying table (below)  
 D = diameter of pipe in feet  
 h = total head in feet  
 L = total length of pipe in feet

To obtain volume flow from Velocity flow, multiply the velocity in feet per second by the area of the pipe/orifice in feet to obtain cubic feet per second.

$$V1 = V \cdot (D/2)^2 \cdot \pi$$

V1 = approximate mean flow in ft<sup>3</sup> per second

#### Equivalent water volume flow in liters per second

$$Vw = V \sqrt{\frac{r}{1000}}$$

Vw = equivalent water volume flow in liters/second  
 r = density of fluid at operating condition in kg/m<sup>3</sup>  
 V = volume of fluid at operating condition in liters/second

Diameter of Pipe		C
Feet	Inches	
0.1	1.2	23
0.2	2.4	30
0.3	3.6	34
0.4	4.8	37
0.5	6.0	39
0.6	7.2	42
0.7	8.4	44
0.8	9.6	46
0.9	10.8	47
1.0	12	48
1.5	18	53
2.0	24	57
2.5	30	60
3.0	36	62
3.5	42	64
4.0	48	66
5.0	60	68
6.0	72	70
7.0	84	72
8.0	96	74
10.0	120	77

### Common Conversion Factors

#### Length

1 in. = 25.4 mm  
 1 in. = 2.54 cm  
 1 in. = 0.0254 m  
 1 ft. = 0.3048 m

#### Area

1 in<sup>2</sup> = 645.2 mm<sup>2</sup>  
 1 in<sup>2</sup> = 6.452 cm<sup>2</sup>  
 1 ft<sup>2</sup> = 144 in<sup>2</sup>

#### Volume

1 in<sup>3</sup> = 16.39 cm<sup>3</sup>  
 1 ft<sup>3</sup> = 1,728 in<sup>3</sup>  
 1 ft<sup>3</sup> = 28.32 liters  
 1 U.S. gal. = 231 in<sup>3</sup>  
 1 U.S. gal. = 0.1337 ft<sup>3</sup>  
 1 U.S. gal. = 3.7854 liters

#### Volume

1 lb/ft<sup>3</sup> = 16.02 kg/m<sup>3</sup>  
 1 lb/ft<sup>3</sup> = 0.01602 g/cm<sup>3</sup>  
 1 lb/in<sup>3</sup> = 1728 lb/ft<sup>3</sup>  
 density = specific gravity \* reference density  
 density = 1/specific volume

#### Specific Volume

specific volume = 1/density

#### Flow Rate

Cv = 1.17 Kv

#### mass units

1 lb/hr = 0.4536 kg/hr  
 1 metric tonne/hr = 2205 lb/hr

#### liquid volume units

1 U.S. gpm = 34.28 BOPD  
 BOPD = barrels oil per day  
 1 U.S. gpm = 0.8327 Imp. gpm  
 1 U.S. gpm = 0.2273 m<sup>3</sup>/hr  
 1 U.S. gpm = 3.785 liters/min  
 1 m<sup>3</sup>/hr = 16.68 liters/min  
 1 ft<sup>3</sup>/s = 448.8 U.S. gpm

## ***Gestra® Engineering Data***

---

### **Pressure**

1 foot of water at 60°F = **0.4332 psi**

1 meter of water at 20°C = 9.790 kN/m<sup>2</sup>

1 meter of water at 20°C = 97.90 mbar

1 meter of water at 20°C = **1.420 psi**

1 mbar = **69 psi**

1 psi = 6,895 Pa

1 psi = 6,895 N/m<sup>2</sup>

**0.145 psi** = 1 kilopascal

1 kgf/cm<sup>2</sup> = **14.22 psi**

1 bar = 100,000 N/m<sup>2</sup>

1 bar = **14.5 psi**

# Gestra® Engineering Data

## Steam Table

Absolute Pressure (psia)	Gage Pressure (psig)	Temperature (°F)	Heat of the Liquid $h_f$ (Btu/lb)	Heat of Evaporation $h_{fg}$ (Btu/lb)	Total Heat of Steam $h_g$ (Btu/lb)	Specific Volume V (ft <sup>3</sup> /lb)	
						Water	Steam
0.088	0.02	32.02	0.00	1075.5	1075.5	0.016022	3302.40
2.0	4.07	126.07	94.03	1022.1	1116.2	0.016230	173.760
4.0	8.14	152.96	120.92	1006.4	1127.3	0.016358	90.6400
6.0	12.22	170.05	138.03	996.2	1134.2	0.016451	61.9840
8.0	16.29	182.86	150.87	988.5	1139.3	0.016527	47.3450
10.0	20.36	193.21	161.26	982.1	1143.3	0.016592	38.4200
12.0	24.43	201.96	170.05	976.6	1146.7	0.016650	32.3940
14.0	28.50	209.56	177.71	971.9	1149.6	0.016702	28.0430
<b>14.696</b>	<b>0.0</b>	<b>212.00</b>	<b>180.17</b>	<b>970.3</b>	<b>1150.5</b>	<b>0.016719</b>	<b>26.7990</b>
15.0	0.3	213.03	181.21	969.7	1150.9	0.016726	26.2900
20.0	5.3	227.96	196.27	960.1	1156.3	0.016834	20.0870
25.0	10.3	240.07	208.52	952.1	1160.6	0.016927	16.3010
30.0	15.3	250.34	218.90	945.2	1164.1	0.017009	13.7436
35.0	20.3	259.29	228.00	939.1	1167.1	0.017083	11.8959
40.0	25.3	267.25	236.10	933.6	1169.8	0.017151	10.4965
45.0	30.3	274.44	243.50	928.6	1172.0	0.017214	9.3988
50.0	35.3	281.02	250.20	923.9	1174.1	0.017274	8.5140
55.0	40.3	287.08	256.40	919.5	1175.9	0.017329	7.7850
60.0	45.3	292.71	262.20	915.4	1177.6	0.017383	7.1736
65.0	50.3	297.98	267.60	911.5	1179.1	0.017433	6.6533
70.0	55.3	302.93	272.70	907.8	1180.6	0.017482	6.2050
75.0	60.3	307.61	277.60	904.3	1181.9	0.017529	5.8144
80.0	65.3	312.04	282.10	900.9	1183.1	0.017573	5.4711
85.0	70.3	316.26	286.50	897.7	1184.2	0.017617	5.1669
90.0	75.3	320.28	290.70	894.6	1185.3	0.017659	4.8953
95.0	80.3	324.13	294.70	891.5	1186.2	0.017700	4.6514
100.0	85.3	327.82	298.50	888.6	1187.2	0.017740	4.4310
105.0	90.3	331.37	302.50	885.8	1188.0	0.017780	4.2309
110.0	95.3	334.79	305.80	883.1	1188.9	0.017820	4.0484
115.0	100.3	338.08	309.30	880.4	1189.6	0.017850	3.8813
120.0	105.3	341.27	312.60	877.8	1190.4	0.017890	3.7275
125.0	110.3	344.35	315.80	875.3	1191.1	0.017920	3.5857
130.0	115.3	347.33	319.00	872.8	1191.7	0.017960	3.4544
135.0	120.3	350.23	322.00	870.4	1192.4	0.017990	3.3325
140.0	125.3	353.04	325.00	868.0	1193.0	0.018030	3.2190
145.0	130.3	355.77	327.80	865.7	1193.5	0.018060	3.1130
150.0	135.3	358.43	330.60	863.4	1194.1	0.018090	3.0139
155.0	140.3	361.02	333.35	861.2	1194.6	0.018125	2.9211
160.0	145.3	363.55	336.10	859.0	1195.1	0.018150	2.8336
165.0	150.3	366.02	338.70	856.9	1195.6	0.018185	2.7515
170.0	155.3	368.45	341.20	854.8	1196.0	0.018210	2.6738
175.0	160.3	370.78	343.80	852.7	1196.5	0.018245	2.6006
180.0	165.3	373.08	346.20	850.7	1196.9	0.018270	2.5312
185.0	170.3	375.33	348.60	848.7	1197.3	0.018305	2.4655
190.0	175.3	377.53	350.90	846.7	1197.6	0.018330	2.4030
195.0	180.3	379.69	353.30	844.8	1198.0	0.018355	2.3438
200.0	185.3	381.80	355.50	842.8	1198.3	0.018390	2.2873
205.0	190.3	383.88	357.70	840.9	1198.7	0.018410	2.2335

Abstracted from ASME Steam Tables (1967) with permission of the publisher, The American Society of Mechanical Engineers, 345 East 47th Street, New York, New York 10017.

## Gestra® Engineering Data

### Steam Table

Absolute Pressure (psia)	Gage Pressure (psig)	Temperature (°F)	Heat of the Liquid $h_f$ (Btu/lb)	Heat of Evaporation $h_{fg}$ (Btu/lb)	Total Heat of Steam $h_g$ (Btu/lb)	Specific Volume V (ft <sup>3</sup> /lb)	
						Water	Steam
210.0	195.3	385.91	359.90	839.1	1199.0	0.018440	2.1822
215.0	200.3	387.91	362.10	837.2	1199.3	0.018470	2.1332
220.0	205.3	389.88	364.20	835.4	1199.6	0.018500	2.0863
225.0	210.3	391.80	366.20	833.6	1199.9	0.018520	2.0414
230.0	215.3	393.70	368.30	831.8	1200.1	0.018550	1.9985
235.0	220.3	395.56	370.30	830.1	1200.4	0.018570	1.9573
240.0	225.3	397.39	372.30	828.4	1200.6	0.018600	1.9177
245.0	230.3	399.19	374.20	826.6	1200.9	0.018630	1.8797
250.0	235.3	400.97	376.10	825.0	1201.1	0.018650	1.8432
255.0	240.3	402.72	378.00	823.3	1201.3	0.018680	1.8080
260.0	245.3	404.44	379.90	821.6	1201.5	0.018700	1.7742
265.0	250.3	406.13	381.70	820.0	1201.7	0.018730	1.7416
270.0	255.3	407.80	383.60	818.3	1201.9	0.018750	1.7101
275.0	260.3	409.45	385.40	816.7	1202.1	0.018780	1.6798
280.0	265.3	411.07	387.10	815.1	1202.3	0.018800	1.6505
285.0	270.3	412.67	388.90	813.6	1202.5	0.018820	1.6222
290.0	275.3	414.25	390.60	812.0	1202.6	0.018850	1.5948
295.0	280.3	415.81	392.30	810.4	1202.7	0.018870	1.5684
300.0	285.3	417.35	394.00	808.9	1202.9	0.018890	1.5427
350.0	335.3	431.70	409.80	794.2	1204.0	0.019125	1.3266
400.0	385.3	444.60	424.20	780.4	1204.6	0.019340	1.1609
450.0	435.3	456.27	437.30	767.5	1204.8	0.019545	1.0323
500.0	485.3	467.01	449.50	755.1	1204.7	0.019750	0.9276
550.0	535.3	476.93	460.90	743.4	1204.3	0.019940	0.8420
600.0	585.3	486.20	471.70	732.0	1203.7	0.020130	0.7698
650.0	635.3	494.88	481.90	721.0	1202.9	0.020320	0.7086
700.0	685.3	503.08	491.60	710.2	1201.8	0.020500	0.6556
750.0	735.3	510.83	500.90	699.8	1200.7	0.020685	0.6096
800.0	785.3	518.21	509.80	689.6	1199.4	0.020870	0.5690
850.0	835.3	525.23	518.40	679.6	1197.9	0.021050	0.5331
900.0	885.3	531.95	526.70	669.7	1196.4	0.021230	0.5009
950.0	935.3	538.39	534.75	659.9	1194.8	0.021410	0.4721
1000.0	985.3	544.58	542.60	650.4	1192.9	0.021590	0.4459
1100.0	1085.3	556.28	557.50	631.5	1189.1	0.021950	0.4006
1200.0	1185.3	567.19	571.90	613.0	1184.6	0.022320	0.3625
1300.0	1285.3	577.42	585.60	594.6	1180.2	0.022690	0.3299
1400.0	1385.3	587.07	598.80	567.5	1175.3	0.023070	0.3018
1500.0	1485.3	596.20	611.70	558.4	1170.1	0.023460	0.2772
1600.0	1585.3	604.87	624.20	540.3	1164.5	0.023870	0.2555
1700.0	1685.3	613.13	636.50	522.2	1158.6	0.024280	0.2361
1800.0	1785.3	621.02	648.50	503.8	1152.3	0.024720	0.2186
1900.0	1885.3	628.56	660.40	485.2	1145.6	0.025170	0.2028
2000.0	1985.3	635.80	672.10	466.2	1138.3	0.025650	0.1883
2100.0	2085.3	642.76	683.80	446.7	1130.5	0.026150	0.1750
2200.0	2185.3	649.45	695.50	426.7	1122.2	0.026690	0.1627
2300.0	2285.3	655.89	707.20	406.0	1113.2	0.027270	0.1513
2400.0	2385.3	662.11	719.00	384.8	1103.7	0.027900	0.1408
2500.0	2485.3	668.11	731.70	361.6	1093.3	0.028590	0.1307
2600.0	2585.3	673.91	744.50	337.6	1082.0	0.029380	0.1211
2700.0	2685.3	679.53	757.30	312.3	1069.7	0.030290	0.1119
2800.0	2785.3	684.96	770.70	285.1	1055.8	0.031340	0.1031
2900.0	2885.3	690.22	785.10	254.7	1039.8	0.032620	0.0942
3000.0	2985.3	695.33	801.80	218.4	1020.3	0.034280	0.0850
3100.0	3085.3	700.28	824.00	169.3	993.3	0.036810	0.0745
3200.0	3185.3	705.08	875.50	56.1	931.6	0.044720	0.0566
3208.2	3193.5	705.47	906.00	0.0	906.0	0.050780	0.0508



## GESTRA Steam Systems

Product Range B1

### Compact System for Level Monitoring NRGS 11-1, NRGS 16-1, NRGS 16-1S

### NRGS 11-1, NRGS 16-1 NRGS 16-1S

#### Description

The compact systems NRGS 11-1 and NRGS 16-1 work according to the conductivity measurement principle. With the NRGS 16-1 a maximum of 4 levels can be signalled in conductive liquids:

- High-level alarm, Low-level alarm, pump ON, pump OFF with one switchpoint each.

The NRGS 1...-1 has a switching controller integrated in the electrode terminal box. External switchgear is **not** required.

The NRGS 11-1/NRGS 16-1 are designed to detect and signal different levels in conductive liquids. They are appropriate for use in the power supply, water and chemical industries and particularly suitable for applications in steam boilers and feedwater tanks.

#### Function

The conductivity of the liquid is used to detect the liquid level. Some liquids are conductive, which means that they allow an electric current to flow through them. For the safe functioning of this device a minimum conductivity of the liquid to be monitored is required.

The conductivity measurement method can detect two conditions: electrode tip submerged or exposed, meaning switchpoint reached (or exceeded) or not yet reached. Before installation, the length of the electrode rod must be adapted to the switching levels, e.g. for max./min. alarm, controlling of a valve or pump.

#### Designs

- NRGS 11-1 screwed 1" BSP (DIN ISO 228)
- NRGS 16-1 screwed 1" BSP (DIN ISO 228)
- NRGS 16-1 S flanged DN 50, PN 40, DIN 2635, for marine applications.

#### Technical Data

##### Type Approval N°

NRGS 16-1: TÜV · WRB · 01-388

NRGS 16-1 S: GL 99250-96 HH

LR 98/20075

RiNA No ELE / 30298/1

##### Max. service pressure

NRGS 11-1: 6 barg at 159 °C

NRGS 16-1 / NRGS 16-1S: 32 barg at 238 °C

##### Connections

Screwed 1" BSP, DIN ISO 228

Flanged DN 50, PN 40, to DIN 2635

##### Materials

Case: Die cast aluminium 3.2161 (G AlSi8Cu3)

Stem: Stainless steel 1.4571 (CrNiMoTi17-12-2)

Flange: Forged steel 1.0460 (C 22.8)

Measuring electrodes: S. S. 1.4571

Electrode insulation: PTFE

Spacer disc: PTFE

##### Lengths supplied

500 mm

1000 mm

1500 mm

#### Technical Data - continued -

##### Mains supply

230 V +/- 10 %, 50/60 Hz

115 V +/- 10 %, 50/60 Hz

24 V +/- 10 %, 50/60 Hz (option)

##### Power consumption

5 VA

##### Fuse

Thermal fuse  $T_{max} = 102\text{ °C}$

##### Sensitivity

Range 1: 10  $\mu\text{S/cm}$

Range 2: 0.5  $\mu\text{S/cm}$

##### Electrode voltage

10 V<sub>SS</sub>

##### Output

4 volt-free relay contacts.

Max. contact rating with a switching voltage of 24 V, 115 V and 230 V a. c.: resistive 4 A, inductive 0.75 A at  $\cos\phi\ 0.5$ .

Max. contact rating with a switching voltage of 24 V d. c.: 4 A

Contact material: silver, hard-gold plated.

##### Energizing/deenergizing delay:

3 sec., factory set

##### Indicators and adjustors

4 red LEDs for signalling "electrode submerged", "output relay energized"

One 4-pole code switch for changing sensitivity

##### Cable entry

Cable glands with integral cable clamps

2 x PG 9 (M 16)

1 x PG 16 (M 20)

##### Protection

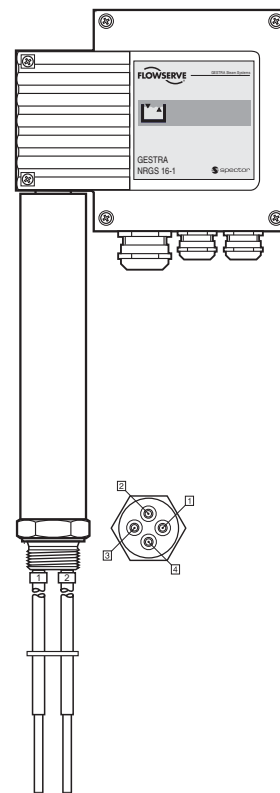
IP 65 acc. to DIN EN 60529

##### Max. permissible ambient temperature

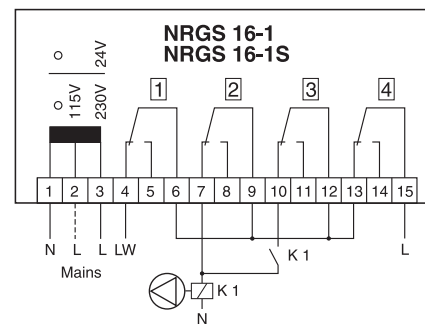
70 °C (158 °F)

##### Weight

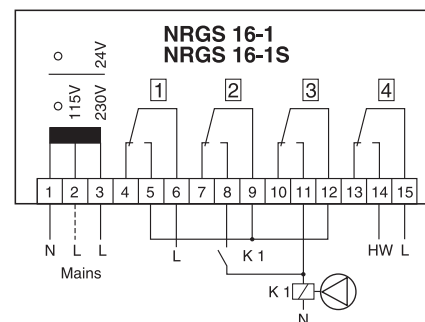
approx. 1.8 kg



Wiring Diagram Fill control



Wiring Diagram Discharge control



# Compact System for Level Monitoring NRGS 11-1, NRGS 16-1, NRGS 16-1S

## Important Notes

Cable required for wiring: multiple-core flexible control cable, min. conductor size 0.5 mm<sup>2</sup>.

## Order and Enquiry Specification

GESTRA Level electrode type  
**NRGS 11-1, NRGS 16-1, PN 40**

Mains supply .....  
Connection .....  
Acceptance inspection .....  
Length supplied .....mm  
GESTRA Level electrode type  
**NRGS 16-1 S, PN 40** (for marine applications)

Mains supply .....  
Acceptance inspection .....  
Length supplied .....mm

The following test certificate can be issued on request, at extra cost: In accordance with EN 10204-2.1, -2.2 and -3.1B.

All inspection requirements have to be stated with the order. After supply of the equipment certification cannot be established. For tests and inspection charges please consult us.

## Key

- ① Lengths supplied: 500 mm  
1000 mm  
1500 mm
- ② Lengths supplied: 438 mm  
938 mm  
1438 mm
- A Flange PN 40, DN 50, DIN 2527  
Flange PN 40, DN 100, DIN 2527
- B For the approval of the boiler standpipe the relevant regulations must be considered.
- C Vent hole
- D High water (HW)
- E Electrode rod  $d = 5$  mm
- F Protection tube  $\geq$  DN 100 mm
- G Electrode distance
- H Low water (LW)
- I Reducer K-88.9 x 3.2 - 42.4 x 2.6 W to DIN 2616, part 2

## ATEX (Atmosphère Explosible)

According to the European Directive 94/9/EC the equipment must not be used in potentially explosive areas.

Supply in accordance with our general terms of business.

## Dimensions

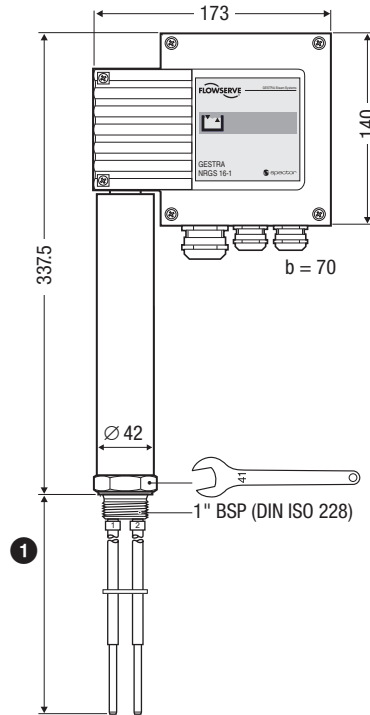


Fig. 1 NRGS 16-1 (NRGS 11-1)

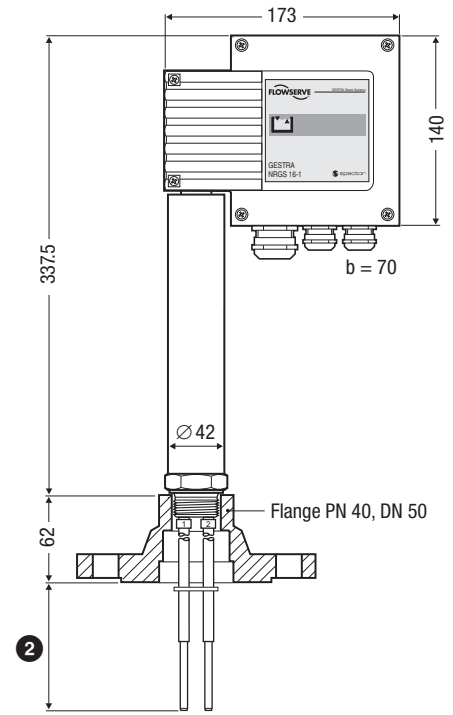


Fig. 2 NRGS 16-1 S

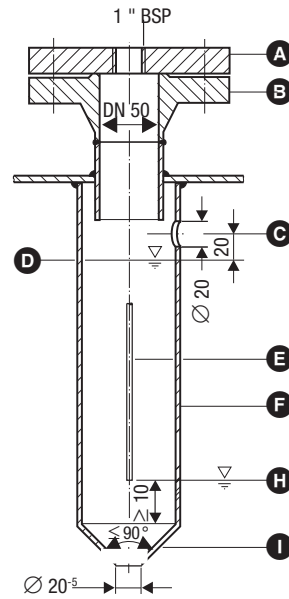


Fig. 3 Protection tube for installation of electrode inside the boiler

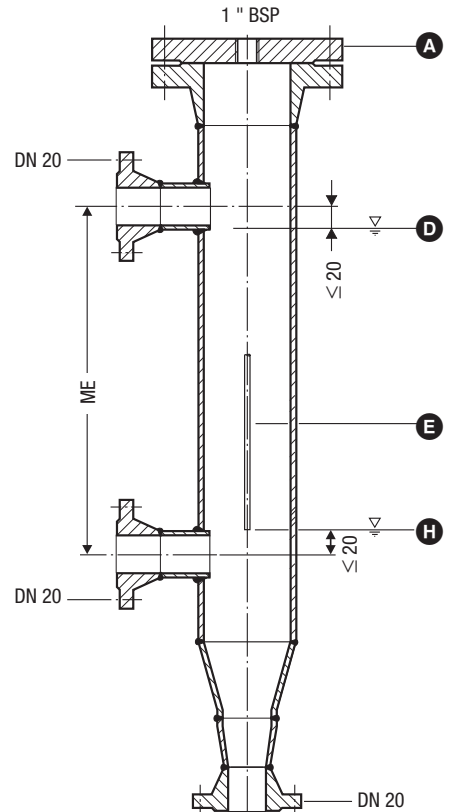


Fig. 4 External measuring pot

# Flowserve GESTRA U.S.

2341 Ampere Drive  
Louisville, KY 40299  
Tel.: 001502 / 2672205, 001502 / 2672206  
Fax: 001502 / 2665397  
Email: dgoodwin@flowserve.com



## GESTRA Steam Systems

Product Range B1

### Compact System for Level Monitoring

#### NRGS 11-2

#### NRGS 16-2

#### Description

The compact system NRGS 11-2, NRGS 16-2 works according to the conductivity measurement principle. With the NRGS 1...-2 a maximum of 3 levels can be signalled in conductive liquids:

- Low level alarm, pump ON, pump OFF with one normally open contact.

The NRGS 1...-2 has its level switch integrated in the electrode case for the control of all functions. An external switching device is **not** required.

The NRGS 1...-2 has two electrode tips for the detection of low-water level. The low-level alarm is signalled via two separate switching channels.

The NRGS 1...-2 is designed to detect and signal different levels in conductive liquids. It is appropriate for use in the power supply, water and chemical industries and particularly suitable for applications in steam boilers and feedwater tanks.

#### Function

The conductivity of the liquid is used to signal the liquid level. Some liquids are conductive, which means that they allow an electric current to flow through them. For the safe functioning of this device a minimum conductivity of the liquid to be measured is required.

The conductivity measurement method can detect two conditions: electrode rod submerged or exposed, meaning switchpoint reached or not reached. Before installation, the length of the electrode tip must be cut to the required switching levels, e. g. for max./min. alarm, controlling of a valve or pump.

#### Design

- NRGS 1...-2 screwed 1", EN ISO 228-1
- Flange DN 50, DN 100 (optional)

#### Technical Data

##### Type approval n°

TÜV · WR/WB · 02-392

##### Max. service pressure

NRGS 11-2: 6 bar g at 159 °C

NRGS 16-2: 32 bar g at 238 °C

##### Connections

Screwed 1", EN ISO 228-1

##### Materials

Terminal box: 3.2161 G AISi8Cu3

Stem: 1.4571 CrNiMoTi17-12-2

Housing: 1.4571

Flange 1.0460 C22.8

Measuring electrodes: 1.4571 CrNiMoTi17-12-2

Electrode insulation: PTFE

Spacer disc: PTFE

##### Lengths supplied

500 mm

1000 mm

1500 mm

#### Technical Data continued

##### Mains supply

230 V +/- 10 %, 50/60 Hz

115 V +/- 10 %, 50/60 Hz

24 V +/- 10 %, 50/60 Hz (optional)

##### Power consumption

5 VA

##### Fuse

Thermal fuse  $T_{max} = 102\text{ °C}$

##### Sensitivity

Range 1: 10  $\mu\text{S/cm}$

Range 2: 0.5  $\mu\text{S/cm}$

##### Electrode voltage

10  $V_{ss}$

##### Output

4 volt-free change-over contacts for low level alarm,

1 normally open contact (e.g. for pump)

Max. contact rating with a switching voltage of 24 V, 115 V and 230 V a. c.: resistive 4 A, inductive 0.75 A at  $\cos \phi$  0.5. Max contact rating with a switching voltage of 24 V d. c.: 4 A.

Contact material: silver, hard-gold plated.

##### Indicators and adjustors

2 red LEDs for signalling "low water",

1 green LED "pump ON",

1 four-pole code switch for changing sensitivity,

1 button for testing the function of low-level alarm

1 button for resetting the low-water alarm.

##### Cable entry

Cable gland with integral cable clamp

M 16 (PG 9)

M 20 (PG 16)

##### Protection

IP 65 acc. to DIN 40050

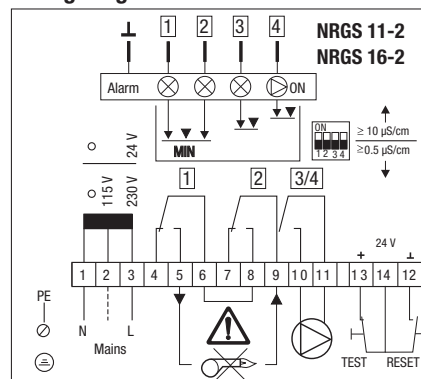
##### Max. admissible ambient temperature

70 °C

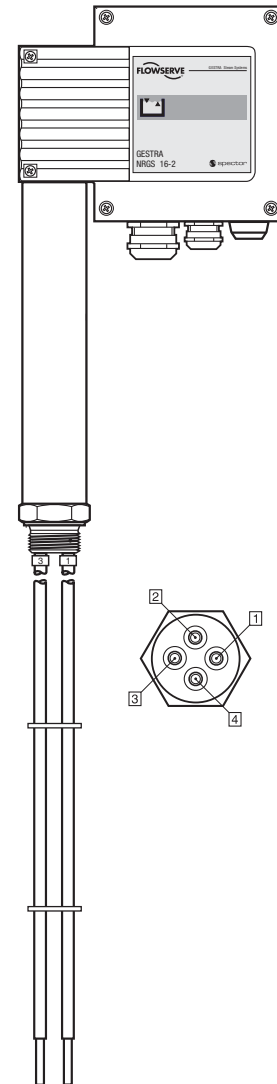
##### Weight

approx. 0.8 kg

#### Wiring Diagram



Relays are shown in the "power-off" position (alarm condition)



# Compact System for Level Monitoring NRGS 11-2 NRGS 16-2

## Important Notes

Cable required for wiring: multiple-core flexible cable, min. conductor size 1.5 mm<sup>2</sup>.

## Order and Enquiry Specification

GESTRA Level electrode type **NRG 11-2**, PN 6  
Mains supply .....  
Connection .....  
Acceptance inspection .....  
Length supplied .....mm

GESTRA Level electrode type **NRGS 16-2**, PN 40  
Mains supply .....  
Connection .....  
Acceptance inspection .....  
Length supplied .....mm

The certificate in accordance with EN 50049-2.1, -2.2 and -3.1B can be issued on request, at extra cost.

All inspection requirements have to be stated with the order. After supply of the equipment certification cannot be established. For tests and inspection charges please consult us.

## Key

- ① Lengths supplied: 500 mm  
1000 mm  
1500 mm
- Ⓐ Flange PN 40, DN 50 DIN 2527  
Flange PN 40, DN 100, DIN 2527
- Ⓑ For the approval of the boiler standpipe with connecting flange the relevant regulations must be considered.
- Ⓒ Vent hole
- Ⓓ High water (HW)
- Ⓔ Electrode rod d = 5 mm
- Ⓕ Protection tube ≥ DN 20
- Ⓖ Electrode distance
- Ⓗ Low water (LW)
- Ⓙ Reducer K-88.9 x 3.2 - 42.4 x 2.6 W to DIN 2616, part 2

Supply in accordance with our general terms of business.

## Dimensions

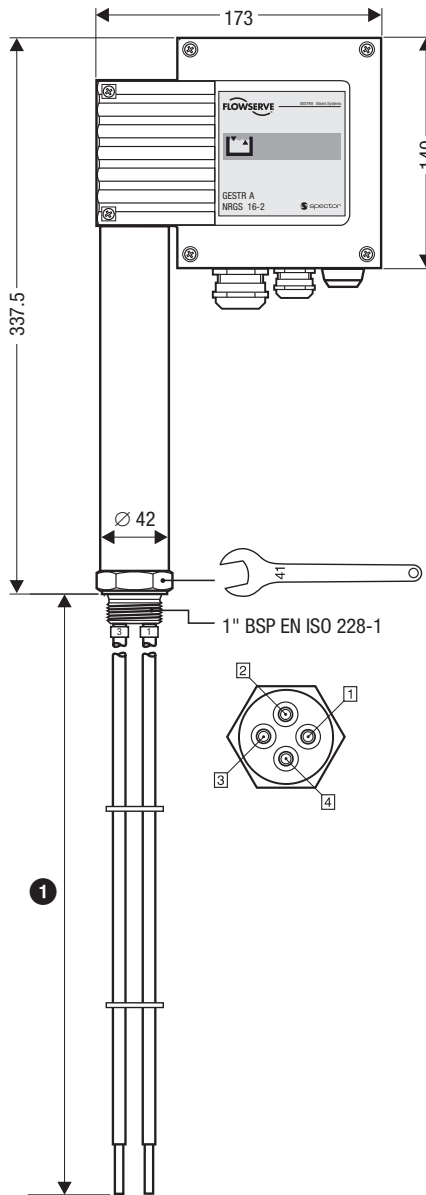


Fig. 1 NRGS 11-2, NRGS 16-2

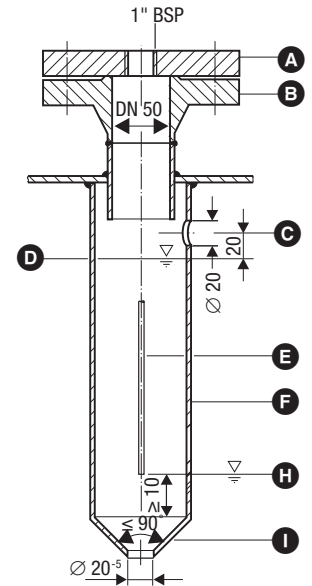


Fig. 2 Protection tube for installation of electrode inside the boiler

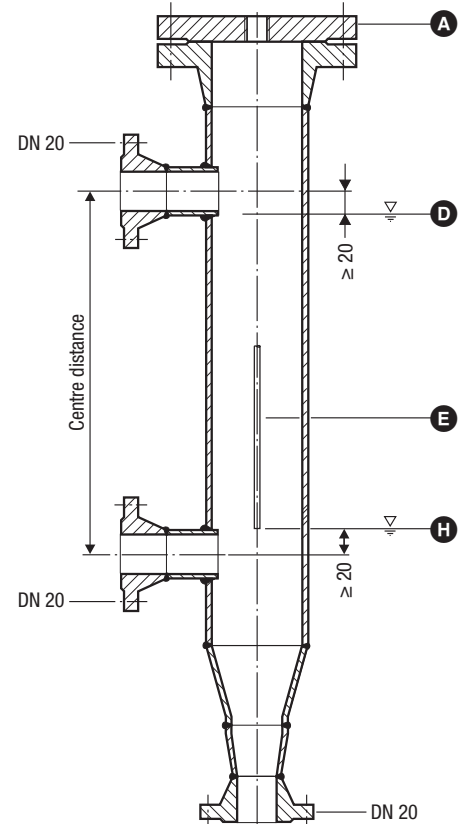


Fig. 3 External measuring pot

# Flowserve GESTRA U.S.

2341 Ampere Drive  
Louisville, KY 40299  
Tel.: 001502 / 2672205, 001502 / 2672206  
Fax: 001502 / 2665397  
Email: dgoodwin@flowserve.com



GESTRA

## GESTRA Steam Systems

## Product Range B

### Compact System for Level Monitoring NRGS 15-1

### NRGS 15-1

#### Description

The compact system NRGS 15-1 works according to the conductivity measurement principle. With the NRGS 15-1 a maximum of four levels can be signalled in conductive liquids:

- Low level/MIN alarm, switchpoint 2, switchpoint 3, high level/MAX alarm

The NRGS 15-1 features a level switch integrated in the terminal box for the control of all functions. External switchgear is therefore **not** required.

The NRGS 15-1 is designed for all applications where several levels of electrically conductive liquids are to be measured. The equipment is suitable for applications in water, energy and chemical industries and particularly well suited for steam boilers, feedwater tanks, condensate tanks and process vessels.

#### Function

The conductivity of the liquid is used to signal the liquid level. Some liquids are conductive, which means that they allow an electric current to flow through them. For the safe functioning of this device a minimum conductivity of the liquid to be measured is required.

The conductivity measurement method can detect two conditions: electrode rod submerged or exposed, meaning switchpoint reached (or exceeded) or not yet reached. Before installation, the length of the electrode rod must be cut to the required switching level, e.g. for limit alarm, valve/pumps on/off.

The NRGS 15-1 has different basic functions for various applications and requirements.

#### Steam boiler (fill control)

- 1** Low level alarm 1, low level alarm 2, pump ON (time-controlled), high-level alarm
- 2** Low level alarm 1, low level alarm 2 *internal lock-out*, pump ON (time-controlled), high level alarm
- 3** Low level alarm, pump ON, pump OFF with one switchpoint each, high level alarm
- 4** Low level alarm with *internal lock-out*, pump ON, pump OFF with one switchpoint each, high level alarm

#### Storage vessel for process control system (discharge control)

- 5** MIN alarm 1, MIN alarm 2, fill control pump ON (time-controlled), MAX alarm
- 6** MIN alarm 1, MIN alarm 2, discharge control pump ON (time-controlled), MAX alarm
- 7** MIN alarm 1, MIN alarm 2, fill control pump ON, pump OFF with one switchpoint each, high level alarm
- 8** MIN alarm 1, MIN alarm 2, discharge control pump ON, pump OFF with one switchpoint each, high level alarm

#### Technical Data

##### Service pressure

NRGS 15-1: 25 bar g at 224 °C

##### Connection

Screwed 1" BSP to EN ISO 228-1

##### Materials

Case: Polycarbonate  
Stem: Stainless steel 1.4571 (CrNiMoTi17-12-2)  
Measuring electrodes: Stainless steel 1.4571 (CrNiMoTi17-12-2)  
Electrode insulation: PTFE  
Spacer disc: PTFE

##### Lengths supplied

1000 mm

##### Mains supply

115 V +/- 10 %, 50/60 Hz  
230 V +/- 10 %, 50/60 Hz

##### Power consumption

5 VA

##### Fuse

Thermal fuse  $T_{max} = 100\text{ °C}$

##### Sensitivity

Range 1: 10  $\mu\text{S/cm}$  (25 °C)  
Range 2: 0.5  $\mu\text{S/cm}$  (25 °C)

##### Electrode voltage

20  $V_{ss}$

##### Output

4 volt-free change-over contacts  
Max. contact rating with a switching voltage of 24 V, 115 V and 230 V a. c.: resistive 4 A, inductive 0.75 A at  $\cos \varphi 0.5$ .  
Max. contact rating with a switching voltage of 24 V d. c.: 4 A.  
Contact material: silver, hard-gold plated.

##### Delay of response

Low level/MIN: 1 sec., factory set  
Switchpoint 2: 0 – 30 sec., adjustable  
Switchpoint 3: 1 sec., factory set  
High level/MAX: 3 sec., factory set

##### Indicators and adjusters

3 red LEDs for signalling "Low level 1/MIN 1", "Low level 2/MIN 2" and "High level/MAX".  
1 yellow LED for signalling "Pump ON"  
1 green LED for signalling "Power ON"  
1 adjustment potentiometer 0 – 30 sec. for "Pump ON"  
1 (optional) pushbutton "TEST" for testing the safety function  
1 (optional) pushbutton "RESET" for resetting the internal lock-out function  
1 ten-pole code switch for selecting the response sensitivity and function.

##### Cable entry

Cable gland with integral cable clamp M 16 (PG 9) (3)

##### Protection

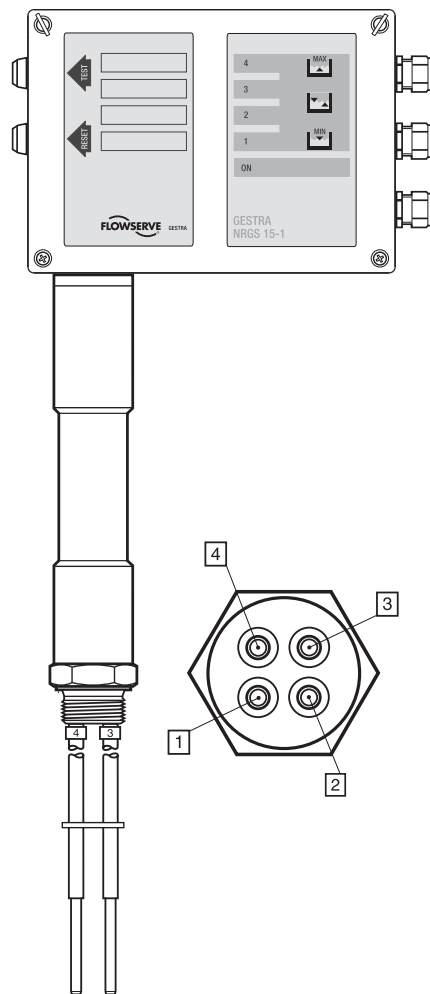
IP 65 to EN 60529

##### Max. permissible ambient temperature

70 °C

##### Weight

approx. 1.4 kg



**Attention:**  
This equipment must only be operated **outside** the European Union!

# Compact System for Level Monitoring NRGS 15-1

## Important Notes

Cable required for wiring: multi-core flexible cable, min. conductor size 0.5 mm<sup>2</sup>

### ATEX Directive 94/9/EC

The equipment must not be used in potentially explosive areas!

## Order and Enquiry Specification

GESTRA Level electrode

**NRGS 15-1, PN 40**

Mains supply .....  
Length supplied: 1000 mm

GESTRA Level electrode

**NRGS 15-1, PN 40, with pushbuttons "TEST" and "RESET" (system test, internal lock-out)**

Mains supply .....  
Length supplied: 1000 mm

## Dimensions

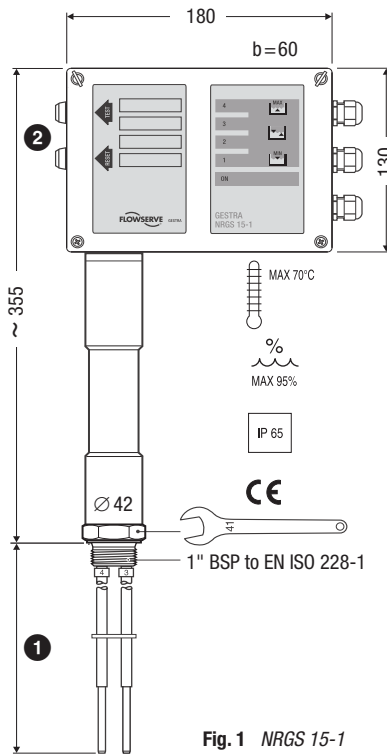


Fig. 1 NRGS 15-1

## Wiring

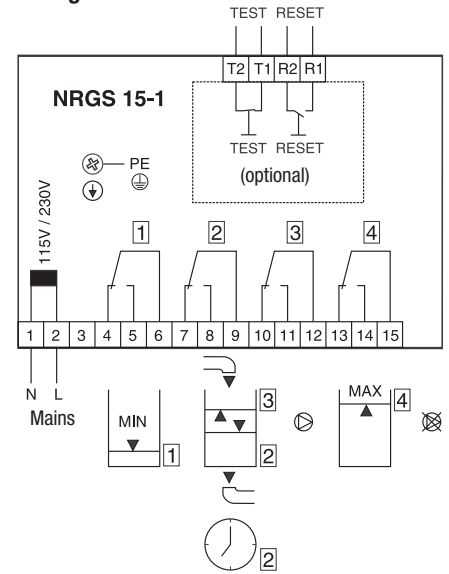


Fig. 2 Wiring diagram

## Key

- ① Length supplied: 1000 mm
- ② Pushbutton "TEST" for system test and pushbutton "RESET" for reset after low-level alarm (optional)
- A Flange PN 40, DN 50, EN 1092-1
- B Vent hole
- C High level HW
- D Electrode rod d = 5 mm
- E Protection tube ≥ DN 100
- F Electrode distance
- G Low level LW
- H Reducer DIN 2616-2 K-88.9 x 3.2 – 42.4 x 2.6 W

Supply in accordance with our general terms of business.

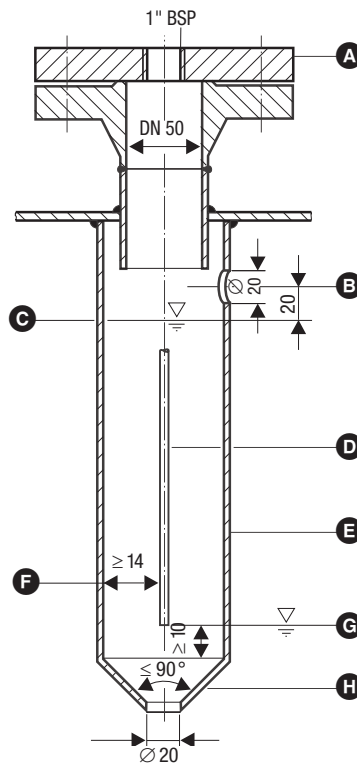


Fig. 3 Protection tube for installation of electrode inside the boiler

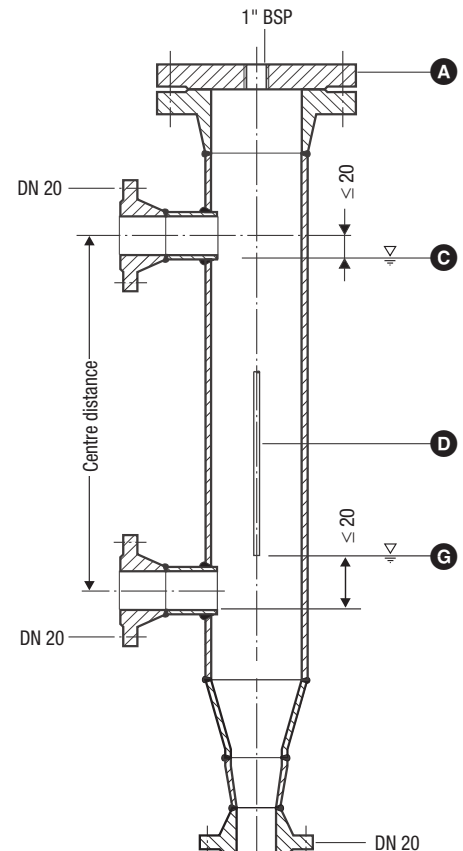


Fig. 4 External measuring pot

# Flowserve GESTRA U.S.

2341 Ampere Drive  
Louisville, KY 40299  
Tel.: 001502 / 2672205, 001502 / 2672206  
Fax: 001502 / 2665397  
Email: dgoodwin@flowserve.com



GESTRA

## GESTRA Steam Systems

Product Range B

### Level Electrode With CAN Bus, CANopen Protocol Type NRG 16-42

### NRG 16-42

#### System Description

The level electrode operation is based on the conductive measuring principle. The NRG 16-42 is designed for signalling max. four liquid levels in electrically conductive liquids:

- 4 levels with **one** switchpoint each
- High-level alarm, low-level alarm, pump ON, pump OFF with **one** switchpoint each.

Use level electrode NRG 16-42 in conjunction with level switch NRS 1-42 or other system components. The level data are transferred from the the electrode to the level switch or an additional system component via CAN data bus, using the CANopen protocol.

#### Function

The conductivity of the liquid is used to signal the liquid level. Some liquids are conductive, which means that they allow an electric current to flow through them. For the safe functioning of this device a minimum conductivity of the liquid to be measured is required.

The conductivity measurement method can detect two conditions: electrode rod submerged or exposed, meaning switchpoint reached (or exceeded) or not yet reached. Before installation, the length of the electrode rod must be cut to the required switching level, e. g. for limit alarms, valve/pumps on/off etc.

At regular intervals the level electrode NRG 16-42 sends a data telegram to the switching controller NRS 1-42. The data are transferred via a CAN bus to DIN ISO 11898 using the CANopen protocol.

#### Design

NRG 16-42 screwed 1" BSP, EN ISO 228-1

#### Technical Data

**Type Approval n°**  
TUV · WR · 04-399

**Max. service pressure**  
32 barg at 238 °C

**Connections**  
Screwed 1" BSP, EN ISO 228-1  
Flanged DN 50, PN 40, DIN 2635

**Materials**  
Terminal box: Die cast aluminium 3.2161 (G AISi8Cu3)  
Stem: S. S. 1.4571 (X6CrNiMoTi17-12-2)  
Measuring electrodes: S. S. 1.4401 (X5CrNiMo17-12-2)  
Electrode insulation: PEEK  
Spacer disk: PTFE

**Lengths supplied**  
500 mm  
1000 mm  
1500 mm

**Supply voltage**  
18–36 V DC

**Current consumption**  
65 mA

**Fuse**  
Thermal fuse  $T_{max} = 85 °C$

**Hysteresis**  
-2 K

**Electrode voltage**  
10  $V_{SS}$

**Data exchange**  
CAN bus to DIN ISO 11898, CANopen protocol

P.T.O.

#### Important Note

Note that screened multi-core twisted-pair control cable is required, e. g. UNITRONIC® BUS CAN 2 x 2 x ... mm<sup>2</sup> or RE-2CYV-fl 2 x 2 x ... mm<sup>2</sup>.

Prefabricated control cables (with connector and coupler) of various lengths for connecting the equipment are available as accessories.

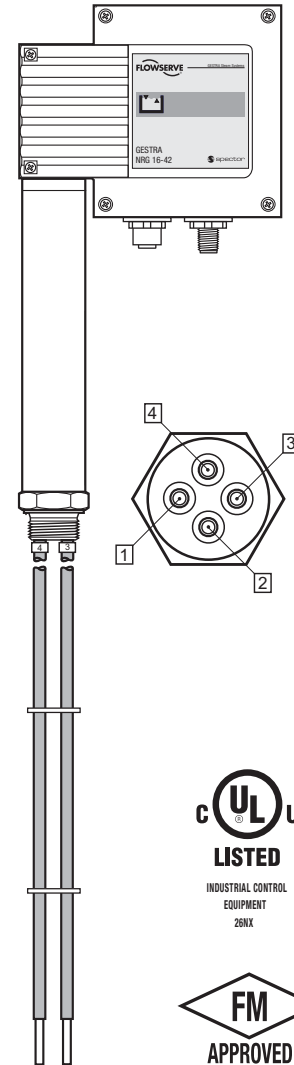
The baud rate (data transfer rate) dictates the cable length between the bus nodes and the total power consumption of the sensor dictates the conductor size.

S 8	S 9	S 10	Baud rate	Cable length	Number of pairs and conductor size [mm <sup>2</sup> ]
OFF	ON	OFF	250 kBit/s	125 m	2 x 2 x 0.34
<b>Factory setting</b>					
ON	ON	OFF	125 kBit/s	250 m	2 x 2 x 0.5
OFF	OFF	ON	100 kBit/s	335 m	2 x 2 x 0.75
ON	OFF	ON	50 kBit/s	500 m	on request, dependent on bus configuration
OFF	ON	ON	20 kBit/s	1000 m	
ON	ON	ON	10 kBit/s	1000 m	

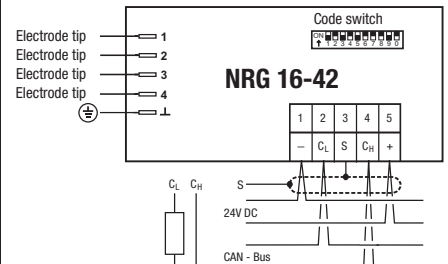
The baud rate is set via a code switch. Reduce baud rate if cable is longer than specified in the table. Make sure that all bus nodes have the same settings.

To protect the switching contacts fuse circuit with 2.5 A (anti-surge fuse) or according to TRD regulations (1.0 A for 72 hrs operation).

**Note: If the cable is longer than 125 m (max. 1000 m!) the baud rate must be changed.**



#### Wiring Diagram



Terminating resistor 120 Ω  
Paired cable

e.g. UNITRONIC®  
BUS CAN 2 x 2 x ...<sup>2</sup>

Level Electrode  
With CAN Bus, CANopen Protocol  
Type NRG 16-42

**Technical Data** – continued –

**Indicators and adjustors**

- 1 green LED for indication "COMMUNICATION CAN BUS"
- 1 red LED "BUS FAULT"
- 1 10-pole code switch for node ID and baud rate settings

**Electric connection**

- M 12 sensor connector, 5 poles, A-coded,
- M 12 sensor jack, 5 poles, A-coded

**Protection**

IP 65 to DIN EN 60529

**Max. admissible ambient temperature**

70 °C

**Weight**

approx. 2.5 kg

**Order and Enquiry Specification**

GESTRA Level electrode type NRG 16-42

**Associated Switching Controller**

- Level switch type NRS 1-42

**Ancillary Unit**

- Visual display unit type URB 1, URB 2

**Key**

- A** Flange PN 40, DN 50, DIN ISO 2527  
Flange PN 40, DN 100, DIN ISO 2527
- B** For the approval of the boiler standpipe with connecting flange the relevant regulations must be considered.
- C** Vent hole
- D** High water (HW)
- E** Electrode rod  $d = 15$  mm
- F** Protection tube DN 80 mm
- G** Electrode distance
- H** Low water (LW)
- I** Reducer K-88.9 x 3.2 – 42.4 x 2.6 W
- M** Lengths supplied  
500 mm  
1000 mm  
1500 mm

**ATEX (Atmosphère Explosible)**

According to the European Directive 94/9/EC the equipment must **not** be used in explosion-risk areas.

Supply in accordance with our general terms of business.

**Dimensions**

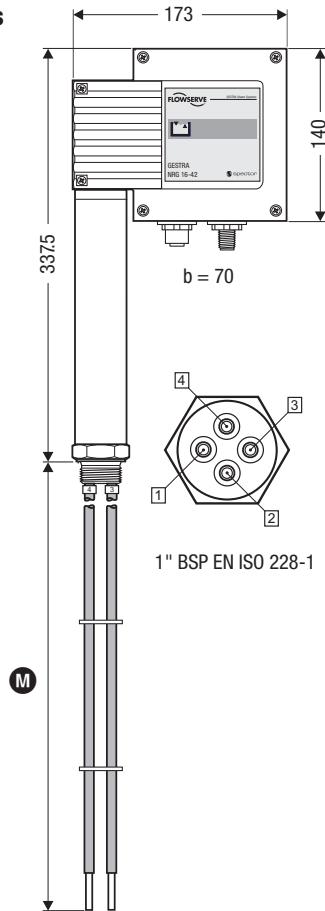


Fig. 1 NRG 16-42

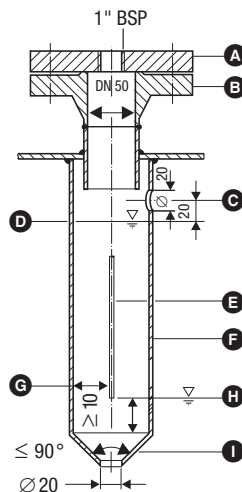


Fig. 2 Protection tube for installation of electrode inside the boiler

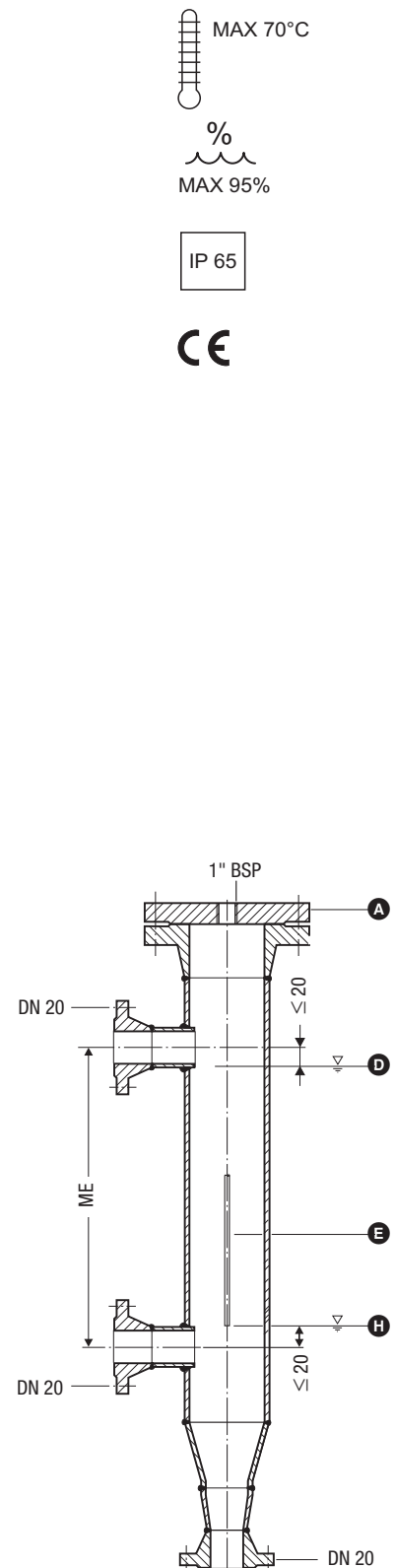


Fig. 3 External measuring pot

MAX 70°C  
%  
MAX 95%  
IP 65  
CE

**Flowserve GESTRA U.S.**

2341 Ampere Drive  
Louisville, KY 40299  
Tel.: 001502 / 2672205, 001502 / 2672206  
Fax: 001502 / 2665397  
Email: dgoodwin@flowserve.com



GESTRA



## GESTRA Steam Systems

Product Range B1

Level Switch Type

**NRS 1-42**

With CAN Bus

**NRS 1-42**

### System Description

Use level switch type NRS 1-42 together with level electrode type NRG 16-42 for level monitoring. The level switch has the following functions:

- Four levels with one switchpoint each.
- High-level alarm, low-level alarm, pump ON, pump OFF with one switchpoint each.

The level data are transferred from the elec-trode NRG 16-42 to the level switch via a CAN bus.

### Function

At regular intervals the level electrode NRG 16-42 sends a data signal to the level switch NRS 1-42. The data transfer is effected by means of a CAN bus according to DIN ISO 11898. The transferred measuring data are then evaluated and assigned to the manually adjusted switchpoints. A de-energizing delay of the relay can be set manually with the control terminal and display unit URB 1. To guarantee the correct functioning and safety of the system the data transmitting cycle of the level switch is constantly monitored. When the CAN bus line is interrupted the level switch sends a visual signal to indicate a malfunction and the relays 1 and 4 will be instantaneously de-energized (fail-safe position).

### Design

#### NRS 1-42 b

Enclosure of insulating material with terminals for installation in control cabinets. The terminals are externally accessible.

Clipping onto a 35 mm standardized supporting rail (DIN EN 50022).

External dimensions: 100 x 73 x 118

### CAN Bus

All level and conductivity switches, controllers and electrodes are interconnected by means of a CAN bus. The data exchange is effected by means of a CAN bus according to DIN ISO 11898 using the CANopen protocol. Every item of equipment features an electronic address (Node ID). The four-core bus cable serves as power supply and data highway for high-speed data exchange.

NRS 1-42 is configured at our works and ready for service with other GESTRA components.

NRS 1-42 can be used straight away without having to set the Node ID.

### Technical Data

#### Type approval n°

TÜV · WR · 98-399

#### Input

Interface for CAN bus to DIN ISO 11898, CANopen

#### Output

Power supply 24V DC, conditionally short-circuit protected. 4 volt-free relay contacts.

Max. contact rating with switching voltages of 24V AC, 115V AC and 230V AC:

4 A ohmic, 0.75 A inductive at  $\cos \varphi 0.5$

Max. contact rating with a switching voltage of 24V DC: 4 A.

Contact material: silver, hard-gold plated

#### Relay de-energizing delay

Output "min", "max" 3 s

#### Indicators and adjustors

1 red LED for switchpoint "MAX"

1 red LED for switchpoint "MIN"

2 green LEDs for switchpoints "PUMP ON" and "PUMP OFF"

1 green LED "POWER ON"

1 red LED "Bus fault"

1 ten-pole code switch for node ID and baud rate

4 push-buttons

#### Supply voltage

230 V +/- 10 %, 50/60 Hz

115 V +/- 10 %, 50/60 Hz (option)

24 V +/- 10 %, 50/60 Hz (option)

#### Power consumption

5 VA

#### Sensitivity

Range 1:  $\geq 10 \mu\text{S/cm}$  (factory setting)

Range 2:  $\geq 0.5 \mu\text{S/cm}$

#### Protection

Case: IP 40 to DIN ISO 60529

Terminal strip: IP 20 to DIN ISO 60529

#### Admissible ambient temperature

0 °C to 55 °C

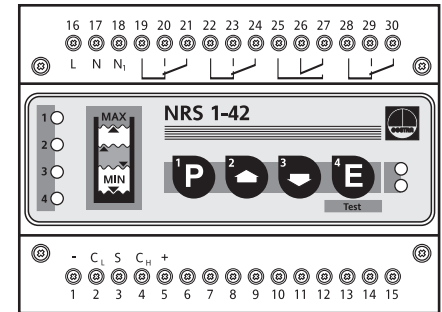
#### Enclosure material

Front panel: polycarbonate, grey

Case: polycarbonate, black

#### Weight

Approx. 0.8 kg



Level Switch Type  
**NRS 1-42**  
 With CAN Bus

**Important Note**

Note that multi-paired control cable is required, e.g. UNITRONIC® BUS Device Net™ drop cable (thin) 2 x 0.25², 2 x 0.34² or RE-2YCYV-fl 2 x 2 x 0.5². Max. cable length 250 m.

To protect the switching contacts fuse circuit with T 2.5 A or according to TRD regulations 1.0 A for 72 h operation.

**Order and Enquiry Specification**

GESTRA Level switch type NRS 1-42 CANopen

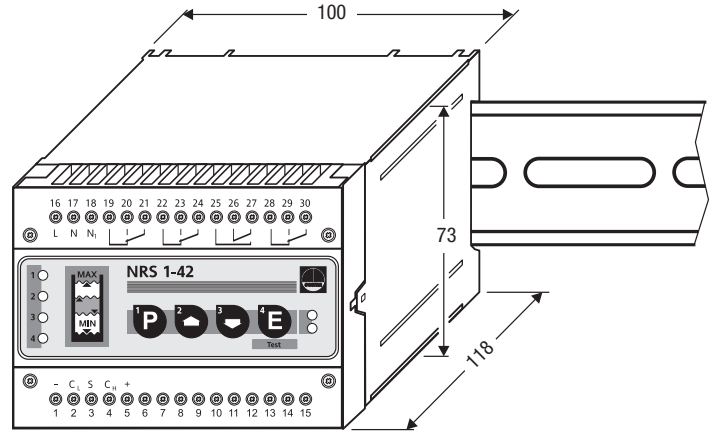
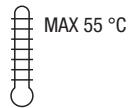
Control equipment .....

Mains voltage .....V

**Ancillary Unit**

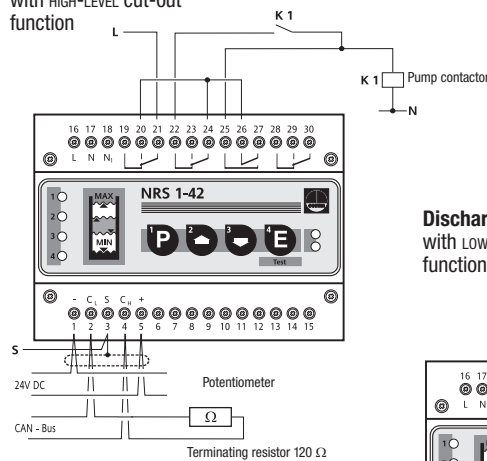
- Conductivity level electrode type NRG 16-42 CANopen

**Dimensions**

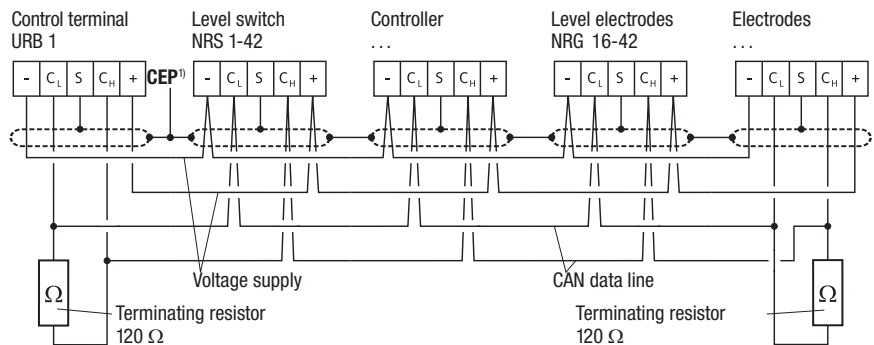
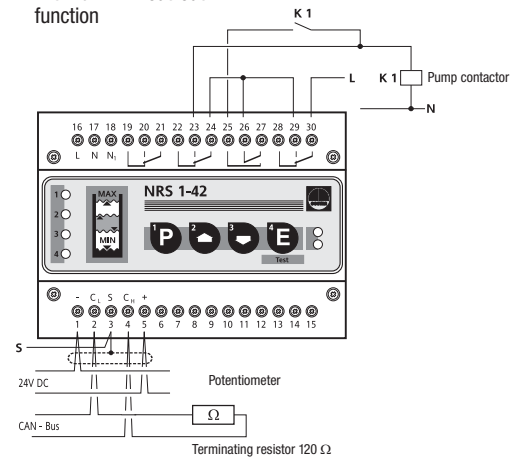


**Wiring Diagram**

**Fill control with HIGH-LEVEL cut-out function**



**Discharge control with LOW-LEVEL cut-out function**



Supply in accordance with our general terms of business.

<sup>1)</sup> CEP = central earthable point

**Flowserve GESTRA U.S.**

2341 Ampere Drive  
 Louisville, KY 40299  
 Tel.: 001502 / 2672205, 001502 / 2672206  
 Fax: 001502 / 2665397  
 Email: dgoodwin@flowserve.com



GESTRA

## GESTRA Steam Systems

Product Range B1

### Level Switch NRS 1-3b

### NRS 1-3

#### Description

Two-channel low-water-level alarm with test button in conjunction with the GESTRA multiple level-control electrode type ER... or level-control electrode type ER 16.

Application in steam boiler plants to TRD 401 and TRD 602.

#### Function

Type-approved two-channel level switch with test button in conjunction with the multiple level-control electrode type ER... or level-control electrode type ER 16/NRG 16-4.

#### Design

Plug-in unit in plastic case for installation in control cabinets. The terminals in the case are accessible after loosening two screws and unplugging the unit from its base. To avoid confusion with other plug-in units of the GESTRA range, inserts are fitted in the bases so that only the correct unit may be plugged into each base.

The plug-in units may be snapped onto a 35 mm supporting rail or screwed into position on a mounting panel.

Field enclosures for several plug-in units are available on request.

#### Technical Data

**Type-approval no.**  
TÜV-WR/WB-03-302

**Note:**  
TÜV-WR... applies to NRS 1-1, 1-2, 1-5,  
TÜV-WB... applies to NRS 1-3;  
combinations of water-level controllers (WR) and  
low-level alarms (WB) are possible due to the type  
approval

**Input**  
2 connections for one electrode tip

**Output**  
2 potential-free relay contacts mounted in series;  
max. contact rating: 250 V, 500 W, 3 A resistive with a life  
of  $4 \times 10^5$  switching cycles or 0.35 A inductive with a life  
of  $2 \times 10^6$  cycles;  
contact material silver, hard-gold plated

**Sensitivity**  
10  $\mu\text{S/cm}$   
(other values available on request)

**Electrode supply voltage**  
11 V AC, free from DC voltage

**Indicators and adjustors**  
2 LEDs "low-level alarm (LW)"  
1 "Test" button for checking electrical circuits  
1 "Reset" button for resetting burner-protection circuit  
after "lock-out" (the connection of an additional push  
button on site is possible; by removing the wire link the  
reset button is without effect)

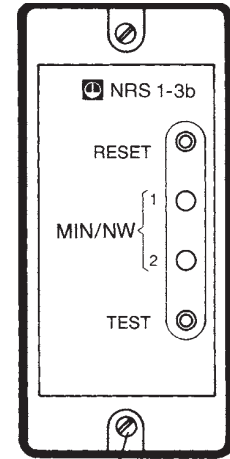
**Mains supply**  
24 V, 110 V, 120 V, 220 V, 240 V, 50... 100 Hz, 3.5 VA  
(please state voltage when ordering),  
24 V DC supply also possible with the ancillary unit  
type URN-1

**Protection**  
IP 40

**Permissible ambient temperature**  
0... 50 °C

**Case materials**  
Base: ABS plastic, black  
Cover: polystyrene (highly shock-resistant),  
stone grey

**Approx. weight**  
0.8 kg



Level switch NRS 1-3b

## Level Switch NRS 1-3b

### Important Notes

Recommended cable for wiring to the electrode: Screened cable, e.g. I-Y (St) Y 2 x 2 x 0.8, max. cable length 100 m.

When mounting the electrode into steam or pressurized hot water boilers the relevant regulations must be considered.

The burner-protection circuit should be fused with 2.5 A (slow blow fuse).

### Order and Enquiry Specifications

GESTRA level switch for two-channel low-level alarm with test button, according to TRD 401 and TRD 602.

Level switch type NRS 1-3b, plug-in unit in plastic case for installation in control cabinets.

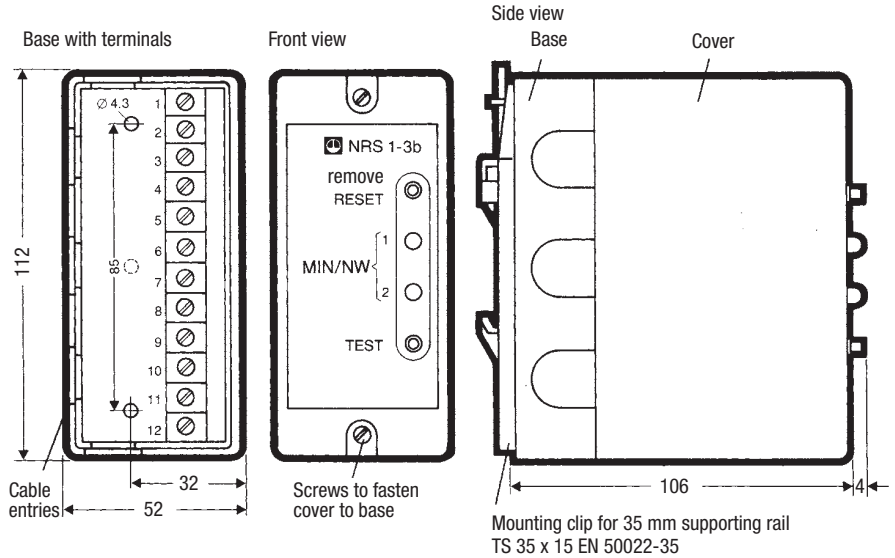
Mains supply..... V

### Associated Equipment

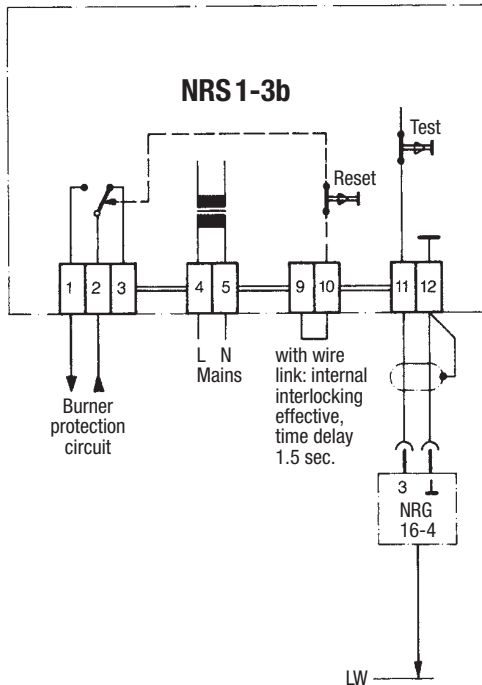
Multiple level-control electrode type ER... with 3 electrode tips and a common earth tip.

Level control electrode type NRG 16-4 with one electrode tip.

### Dimensions



### Wiring Diagram



Supply in accordance with our general terms of business.

Wiring diagram for level switch type NRS 1-3b, drawn position of contacts: relays deenergized, i. e. alarm

## Flowserve GESTRA U.S.

2341 Ampere Drive  
Louisville, KY 40299  
Tel.: 001502 / 2672205, 001502 / 2672206  
Fax: 001502 / 2665397  
Email: dgoodwin@flowserve.com



GESTRA

## GESTRA Steam Systems

Product Range B1

### Level Controller NRS 1-5b

### NRS 1-5

#### Purpose and Application

On-off feedwater control and high-level alarm with the GESTRA multiple level-control electrode type **ER 5 . . .** or level control electrodes type **ER 16**.

Application for feed (fill) control or drain (discharge) control with high-level alarm in steam boilers, condensate and other tanks.

#### Design

Plug-in unit in plastic case for installation in control cabinets. The terminals in the case are accessible after loosening two screws and unplugging the unit from its base. To avoid confusion with other plug-in units of the GESTRA range, inserts are fitted in the bases so that only the correct unit may be plugged into each base.

The plug-in units may be snapped onto a 35 mm supporting rail or screwed into position on a mounting panel.

Field enclosures for several plug-in units are available on request.

#### Technical Data

##### Function

On-off feedwater control and high-level alarm with multiple level-control electrode type **ER 5 . . .** or level control electrodes type **ER 16**.

##### Type-approval no.

TÜV-WR/WB-98-302

##### Input

4 connections for 3 electrode tips

##### Output

1 potential-free working contact for the controller,  
1 potential-free relay contact for the alarm;  
max. contact rating: 250 V, 500 W, 3 A ohmic with a life of  $4 \times 10^5$  switching cycles or 0.35 A inductive with a life of  $2 \times 10^6$  cycles;  
contact material silver, hard-gold plated.

##### Sensitivity

Standard design: 10  $\mu$ S/cm

Special design: 0.5  $\mu$ S/cm

##### Electrode supply voltage

11 VAC, free from DC voltage

##### Indicators and adjustors

1 LED "Pump ON", 1 LED "MAX/HW",

1 switch for selection of operation "Feed" or "Drain" control,

1 "Test" button for simulating "high-level alarm" (HW)

##### Mains supply

24 V, 110 V, 120 V, 220 V, 240 V, 50 . . . 100 Hz, 3.5 VA (please state voltage when ordering),

24 VDC supply also possible with the ancillary unit type URN-1.

##### Protection

IP 40

##### Permissible ambient temperature

0 . . . 50 °C

##### Case materials

Base: ABS plastic, black

Cover: polystyrene (highly shock-resistant), stone grey

##### Approx. weight

0.8 kg

#### Important Notes

Recommended cable for wiring to the electrode(s): Screened cable, e.g. I-Y (St) Y 2 x 2 x 0.8 or LIYCY 0.5 mm<sup>2</sup>, max. cable length 100 m.

When mounting the electrode(s) into steam or pressurized hot water boilers the relevant regulations must be considered.

#### Order and Enquiry Specifications

GESTRA level controller for water-level control and high-level alarm:

Levelcontroller type NRS 1-5b, plug-in unit in plastic case for installation in control cabinets.

Mains supply..... V

#### Associated Equipment

Multiple level-control electrode type ER 5... with 3 electrode tips and a common earth tip.

Level control electrodes type ER 16 with one electrode tip.

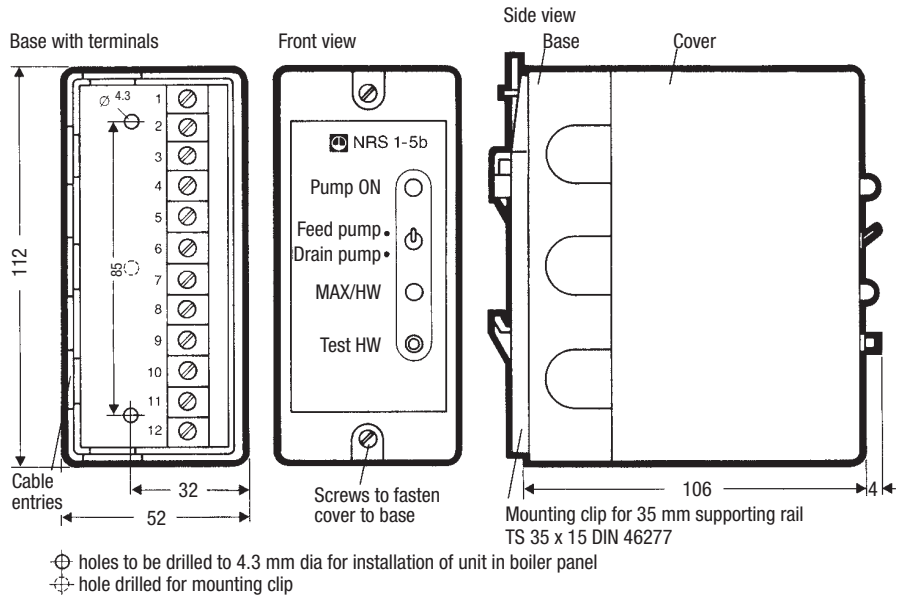
Level switch type NRS 1-2b for signalling of additional MAX and MIN levels.



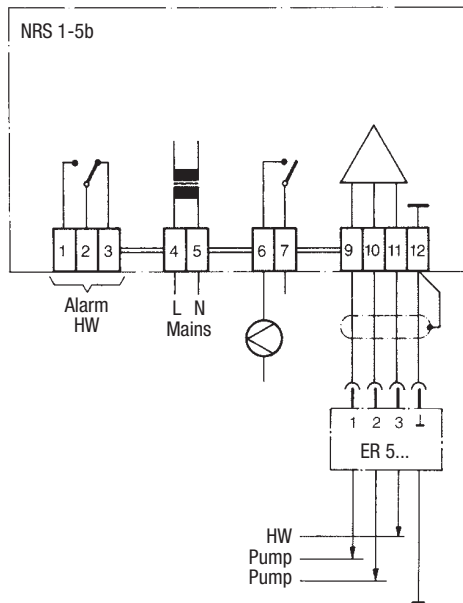
NRS 1-5b

Level Controller  
**NRS 1-5b**

**Dimensions**



**Wiring Diagram**



Wiring diagram for level controller type NRS 1-5b, drawn position of contacts: relays deenergized i.e. alarm

Supply in accordance with our general terms of business.

**Flowserve GESTRA U.S.**

2341 Ampere Drive  
 Louisville, KY 40299  
 Tel.: 001502 / 2672205, 001502 / 2672206  
 Fax: 001502 / 2665397  
 Email: dgoodwin@flowserve.com



GESTRA

## GESTRA Steam Systems

Product Range B

### Compact System for Level Monitoring NRGT 26-1 NRGT 26-1S For Marine Applications

### NRGT 26-1 NRGT 26-1S

#### Description

The compact system NRGT 26-1 works according to the capacitance measurement principle. The NRGT 26-1 is designed for signalling different levels in conductive and non-conductive liquids:

- Water level maintained within the control band defined by two preset limits.

The NRGT 26-1 has a level transmitter integrated in the terminal box which produces a standard output signal of 4-20 mA. External switchgear is **not** required.

#### Function

The principle of capacitance measurement is applied to determine the level. The electrode rod and the vessel wall form a capacitor. If the level of the dielectric located between the two capacitor plates changes, the current which flows through the plates changes proportionally to the level. A dielectric is defined as an insulating substance, which excludes many liquids such as water. In order to receive a useful measuring result the measuring rod, which is completely submerged in the liquid, must be completely insulated. After calibration of the zero point/measuring range (0% - 100%) of the control unit, the level can be read off from a remote display unit. The level measuring range can be changed during operation.

#### Design

##### NRGT 26-1:

Electrode with screwed connection 3/4" BSP, DIN ISO 228-1.

##### NRGT 26-1S:

Flanged design for marine applications DN 50, PN 40, DIN 2635.

#### Technical Data

##### Type approval no.

NRGT 26-1: TÜV · WRS · 02-391  
 NRGT 26-1S: LR 98/20075 RINA ELE/30298/2  
 GL 99249-96HH BV 10617/AO BV  
 NKK A-556 DNV A-8394  
 KR HMB 06190-MS002

##### Service pressure

32 barg at 238°C

##### Connection

NRGT 26-1: Screwed 3/4" BSP, DIN ISO 228-1  
 NRGT 26-1S: Flanged DN 50, PN 40, DIN 2635

##### Materials

Case 3.2161 G AISi8Cu3  
 Stem 1.4571 CrNiMoTi17-12-2  
 Flange 1.0460 P250GH  
 Measuring electrodes 1.4571 CrNiMoTi17-12-2  
 Electrode insulation PTFE  
 Spacer disc PTFE  
 (design for marine applications)

##### Mains supply

230 V +/- 10 %, 50/60 Hz  
 115 V +/- 10 %, 50/60 Hz (optional)  
 24 V +/- 10 %, 50/60 Hz (optional)  
 24 V d.c. (optional)

##### Overall length / measuring range

See table overleaf

#### Power consumption

5 VA

#### Fuse

Thermal fuse  $T_{max} = 102^{\circ}C$

#### Sensitivity

Range 1: Water  $\geq 0.5 \mu S/cm$   
 Range 2: Water  $\geq 20 \mu S/cm$   
 Range 3: Fuel oil EL  $\epsilon_r 2.3$

#### Output

4-20 mA level-proportional.  
 Volt-free, max. load 500  $\Omega$

#### Indicators and adjusters

2 red LEDs for signalling "Level 0%" or "Level 100%" within the measuring range,  
 1 green LED for signalling "Level between 0% and 100%" of measuring range.  
 1 code switch for selecting the measuring range.  
 2 trimmer potentiometers for small-percentage adjustment of the measuring range.  
 2 terminal lugs for voltage metering.

#### Cable entry

Cable gland with integral cable clamp  
 M 20 (PG 16) (2 x)

#### Protection

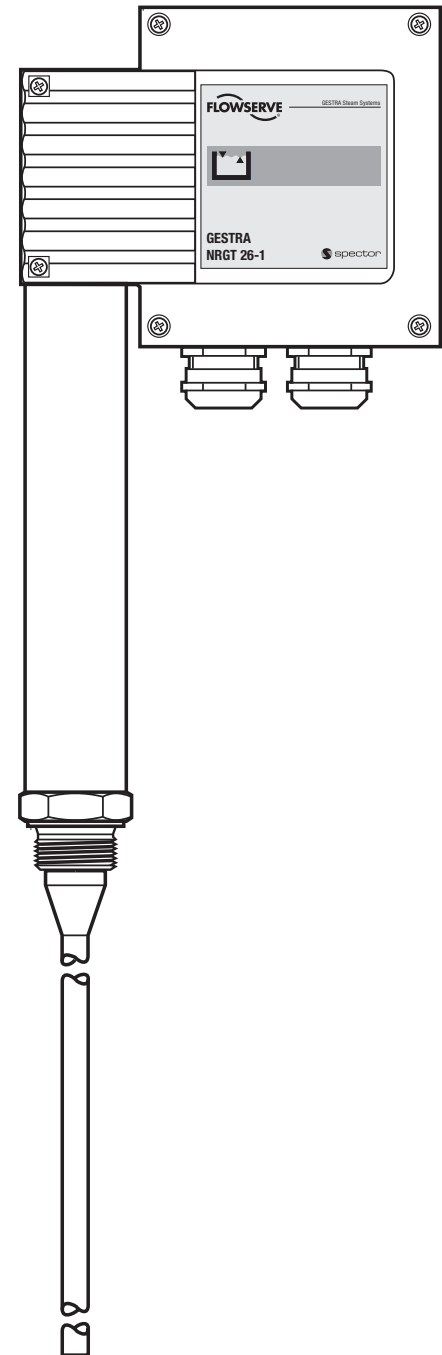
IP 65 to DIN EN 40050

#### Max. admissible ambient temperature

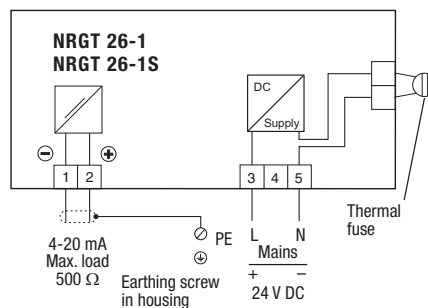
70 °C

#### Weight

NRGT 26-1: Approx. 1.8 kg  
 NRGT 26-1S: Approx. 8.0 kg



#### Wiring diagram



# Compact System for Level Monitoring NRGT 26-1 NRGT 26-1S For Marine Applications

## Important Notes

Cable required for wiring: flexible multi-core control cable, min. conductor size 1.5 mm<sup>2</sup>.

## Order and Enquiry Specification

GESTRA Level electrode **NRGT 26-1**, PN 40  
 Mains supply.....  
 Connection.....  
 Inspection.....  
 Length supplied..... mm  
 Fluid.....

GESTRA Level electrode **NRGT 26-1 S**, PN 40 for marine applications  
 Mains supply.....  
 Connection.....  
 Inspection.....  
 Length supplied..... mm  
 Fluid.....

The following test certificates can be issued on request, at extra cost: In accordance with DIN EN 10204-2.1, -2.2 and -3.1B.

All inspection requirements have to be stated with the order. After supply of the equipment certification cannot be established. For tests and inspection charges please consult us.

## Key

- 1 NRGT 26-1: Max. length of installation at 238 °C
- 2 NRGT 26-1: Measuring range
- 3 NRGT 26-1S: Max. length of installation at 238 °C
- 4 NRGT 26-1S: Measuring range

- 1 Flange PN 40, DN 50, DIN 2527  
Flange PN 40, DN 100, DIN 2527
- 2 For the approval of the boiler standpipe with connecting flange the relevant regulations must be considered.
- 3 Vent hole
- 4 High water (HW)
- 5 Electrode rod d = 15 mm
- 6 Protection tube DN 80
- 10 Low water (LW)
- 11 Reducer DIN 2616, part 2  
K - 88.9 x 3.2 - 42.4 x 2.6 W

## ATEX (Atmosphère Explosible)

According to the European Directive 94/9/EC the equipment must not be used in potentially explosive areas.

Supply in accordance with our general terms of business.

## Dimensions

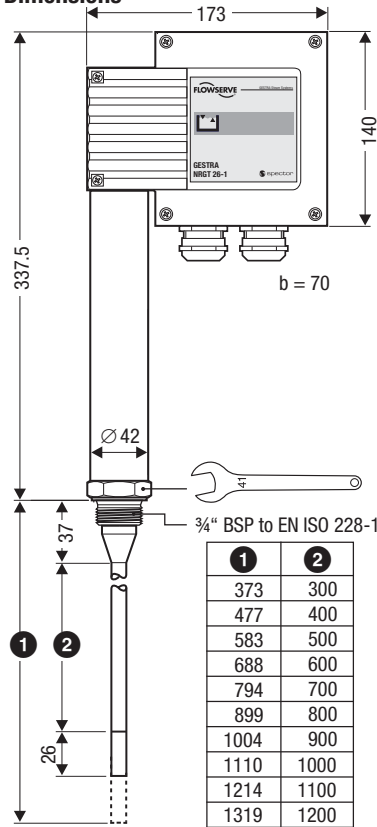


Fig. 1 NRGT 26-1

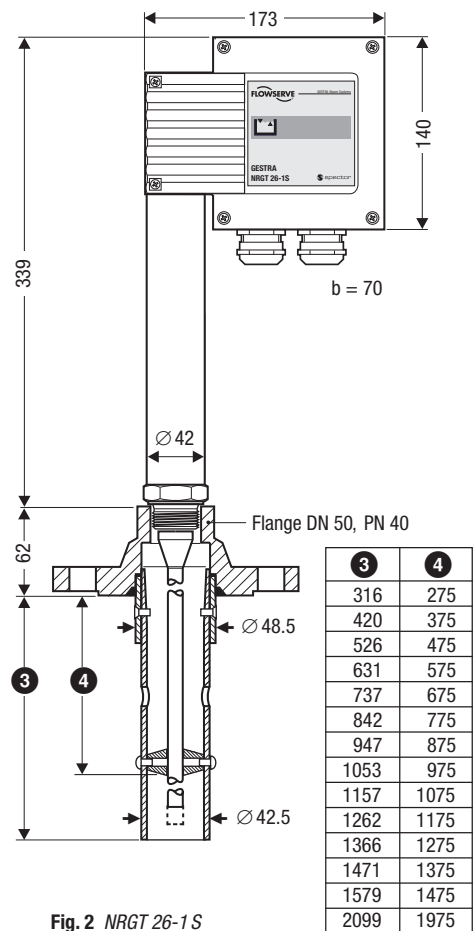


Fig. 2 NRGT 26-1 S

## Examples of Installation

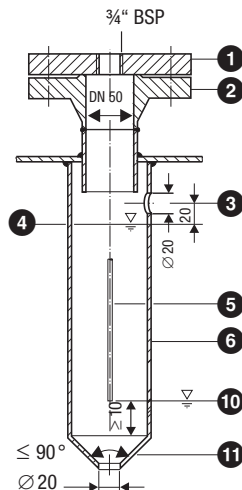


Fig. 3 Protection tube for installation of electrode inside the boiler

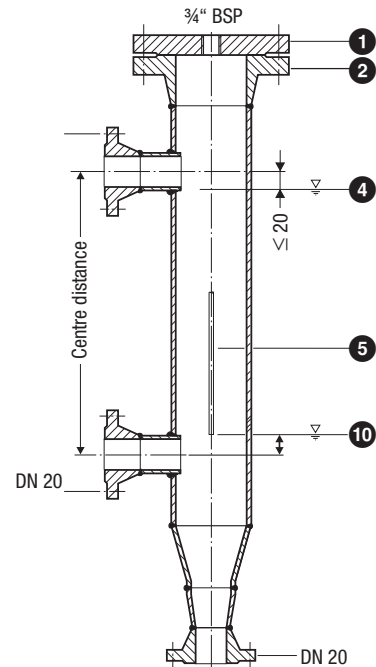


Fig. 4 External measuring pot

# Flowserve GESTRA U.S.

2341 Ampere Drive  
 Louisville, KY 40299  
 Tel.: 001502 / 2672205, 001502 / 2672206  
 Fax: 001502 / 2665397  
 Email: dgoodwin@flowserve.com



GESTRA



## GESTRA Steam Systems

Product Range B1

### Level Switch Type NRS 2-3

### NRS 2-3

#### Purpose and Application

The level switch type NRS 2-3 is an analogue electronic control instrument for the capacitance level electrode NRGT 26-1.

In combination with this compact electrode the switch can signal the following levels

- High level, low level, level control unit ON/OFF

and can be used as level controller for steam boilers and pressurized hot-water plants.

#### Examples of installation

Use level switch NRS 2-3 only in combination with GESTRA compact electrode type NRGT 26-1.

#### Design

##### Design "b"

19" slide-in unit to DIN 41494 part 5, installed on a mounting panel for installation in control cabinets with screw-type terminals at the top and bottom.

##### Design "c"





19" slide-in unit with guide rails and 32 pole screw-type connector for the installation in 19" mounting panels acc. to DIN 41494 part 5.

##### Design "d"

19" spare slide-in unit


#### Function

The level transmitter NRGT 26-1 provides a current signal in proportion with the measured liquid level. This signal is converted into a voltage, which is then fed to three voltage comparators, V1, V2 and V3. The reference voltages of these comparators may be individually set by the adjusters of the face plate of the NRS 2-3. Depending on the relationship of the signal voltage to the adjusted reference voltage, the related relays behave as follows:

- The level signal voltage across V1 is higher than the reference voltage: Relay 1 is de-energised, and the red LED  is illuminated.
- The level signal voltage across V1 is lower than the reference voltage: Relay 1 is energised, and the red LED  is extinguished.
- The level signal voltage across V3 is lower than the reference voltage: Relay 3 is de-energised, and the red LED  is illuminated.
- The level signal voltage across V3 is higher than the reference voltage: Relay 3 is energised, and the red LED  is extinguished.

V2 is used to operate, for example, boiler feed pump ON/OFF control, and this is established by adjustment of the reference voltage of V2, and separate adjustment of hysteresis in the 1% to 50% of measuring range.

- The level signal voltage across V2 is lower than the reference voltage: Relay 2 switches on the pump and the yellow LED  is illuminated.

The level signal voltage across V2 is higher than the reference voltage plus hysteresis: relay 2 switches off the pump and the green LED  is illuminated.

#### Technical Data

**Type approval no.**  
GL 99249-96HH

#### Mains voltage

230 V ± 10%, 50/60 Hz  
115 V ± 10%, 50/60 Hz (option)  
24 V ± 10%, 50/60 Hz (option)

#### Power consumption

5 VA

#### Input

4 – 20 mA (coming from level transmitter)

#### Output

3 volt-free relay contacts

Max. contact rating with switching voltages of 24 V, 115 V and 230 V AC: 4 A resistive, 0.75 A inductive at  $\cos \varphi = 0.5$ .

Max. contact rating with a switching voltage of 24 V DC: 4 A

Service life of relay: 30 x 10<sup>6</sup> switching cycles.

#### Limit value HIGH LEVEL / LOW LEVEL

Continuously adjustable within measuring range of level transmitter

#### Switchpoints Pump ON / OFF

Continuously adjustable within 1 – 50% of the measuring range of level transmitter

#### Indicators and adjusters

1 red LED "HIGH LEVEL", 1 red LED "LOW LEVEL",  
1 yellow LED "PUMP ON", 1 green LED "PUMP OFF".  
4 adjusters for HIGH LEVEL / LOW LEVEL and PUMP ON/OFF.

#### Protection

IP 10 to DIN 40050

#### Max. admissible ambient temperature

0 °C to +70 °C

#### Case

19" slide-in unit with front panel to DIN 41494 part 5 and rear 32 way Euro card connector to DIN 41612 installed in a mounting panel or for installation in 19" mounting panel.  
Front panel, mounting panel: aluminium

#### Wiring

**Design "b"**: screw-type terminal strips at the back of the mounting panel, max. conductor size 1.5 mm<sup>2</sup>

**Design "c"**: 32 pole screw-type connector at the back of the 19" mounting panel, max. conductor size 1.5 mm<sup>2</sup>

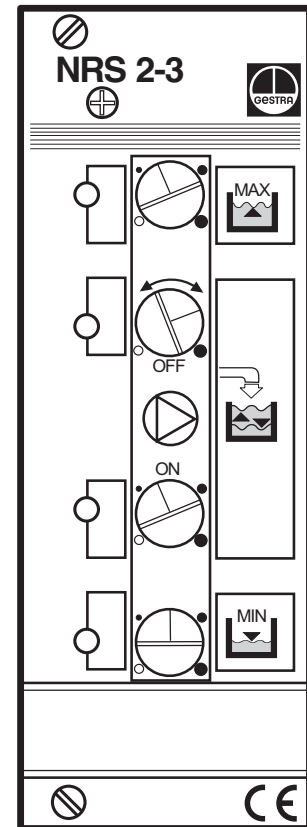
Supply line to compact electrode: screened two-core cable, conductor size 0.5 mm<sup>2</sup>, max. cable length 150 m

#### Internal fuse

Glass cartridge fine-wire fuse M 0.05 M, 5 x 20, replaceable

#### Weight

approx. 0.8 kg



Level switch NRS 2-3

# Level Switch Type NRS 2-3

## Technical Data – continued –

### Scope of supply

#### NRS 2-3, design "b"

- 1 Level switch NRS 2-3
- 1 Mounting panel for installation in control cabinets
- 1 Installation instructions

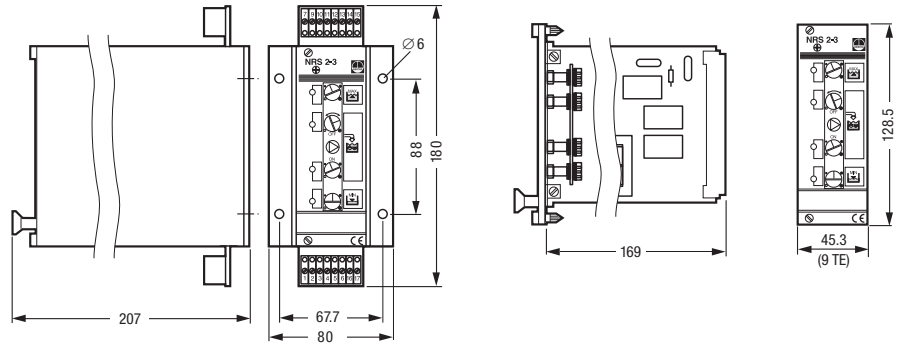
#### NRS 2-3, design "c"

- 1 Level switch NRS 2-3
- 2 Guide rails
- 1 32 pole screw-type connector
- 1 Installation instructions

#### NRS 2-3, design "d"

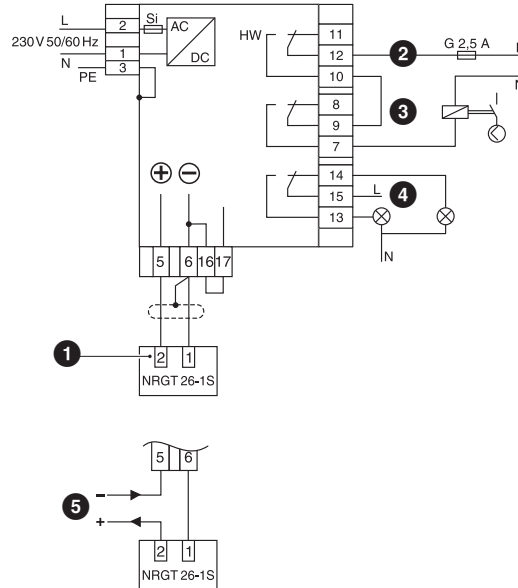
- 1 Level switch NRS 2-3
- 1 Installation instructions

## Dimensions

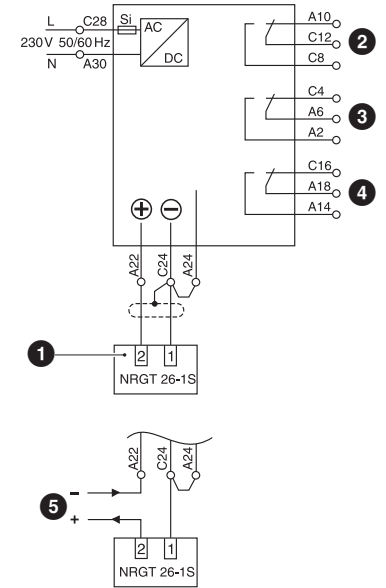


## Wiring diagrams

### Design "b"



### Design "c" / "d"



## Important Note

Note that screened four-core cable is required for wiring, e.g. I-Y(St)Y 2 x 2 x 0.8 or LIYCY 4 x 0.5<sup>2</sup>. Max. cable length 100 m.

To protect the switching contacts fuse circuit with 2.5 A (slow-blow) or according to TRD regulations (1.0 A for 72 h operation).

## Order & Enquiry Specification

GESTRA Level switch NRS 2-3

Design .....

Mains voltage .....V

## Associated Equipment

- Conductivity electrode NRGT 26-1S for level monitoring.

Supply in accordance with our general terms of business.

- 1 Compact electrode
- 2 High level
- 3 Water level controller (fill control)
- 4 Low level, 2<sup>nd</sup> water level indicator: LED red/green
- 5 Connection for another device, e.g. NRR 2-3

# Flowserve GESTRA U.S.

2341 Ampere Drive  
Louisville, KY 40299  
Tel.: 001502 / 2672205, 001502 / 2672206  
Fax: 001502 / 2665397  
Email: dgoodwin@flowserve.com



GESTRA

## GESTRA Steam Systems

Product Range B

### Level Electrode With CAN Bus, CANopen Protocol Type NRG 26-40

### NRG 26-40

#### System Description

The level electrode NRG 26-40 works according to the capacitance measurement principle. The NRG 26-40 is used for signalling different levels in conductive and non-conductive liquids:

- Water level maintained within the control band defined by two preset limits.

Use level electrode NRG 26-40 in combination with level switch type NRS 2-40 or further system components. The level data are transferred to the level switch or another system component via the CAN data bus. The controller and the electrode use the CANopen protocol.

#### Function

The principle of capacitance measurement is applied to determine the level. The electrode rod and the vessel wall form the plates of a capacitor. If the level of the dielectric located between these two capacitor plates changes, the current which flows through the plates changes proportionally to the level. A dielectric is by definition an insulating substance, which excludes many liquids such as water. In order to receive a useful measuring result the measuring rod, which is submerged to varying depths in the liquid, must be completely insulated. After the calibration of the zero point/measuring range (0%/100%) the level can be read off from a remote display unit. The level measuring range can be changed during operation.

At regular intervals the level electrode NRG 26-40 sends a data signal to the level switch NRS 2-40 or level controller NRR 2-40. The data transfer is effected by means of a CAN bus according to DIN ISO 11898 using the CAN open protocol.

#### Design

NRG 26-40 screwed 3/4" BSP EN ISO 228-1

#### Technical Data

**Type Approval N°**  
TÜV · WR · 04-399

**Max. service pressure**  
32 barg at 238 °C

**Connections**  
Screwed 3/4" BSP, EN ISO 228-1

**Materials**  
Case Die cast aluminium 3.2161(G AISi8Cu3)  
Stem S. S. 1.4571 (X6CrNiMoTi17-12-2)  
Measuring electrodes S. S. 1.4401 (X5CrNiMo17-12-2)  
Electrode insulation PTFE

**Length supplied**  
300 mm to 2000 mm

**Supply voltage**  
18 – 36 V DC

**Current consumption**  
65 mA

**Fuse**  
Thermal fuse  $T_{max} = 80 °C$

**Hysteresis**  
-2 K

**Data exchange**  
CAN bus acc. to DIN ISO 11898,  
CANopen protocol

**Indicators and adjustors**  
1 green LED for indication "CAN BUS COMMUNICATION"  
1 red LED "BUS FAULT"  
1 10-pole code switch for node ID and baud rate settings

P.T.O.

#### Wiring

Note that screened multi-core twisted-pair control cable is required, e. g. UNITRONIC® BUS CAN 2 x 2 x ... mm<sup>2</sup> or RE-2YCYV-fl 2 x 2 x ... mm<sup>2</sup>.

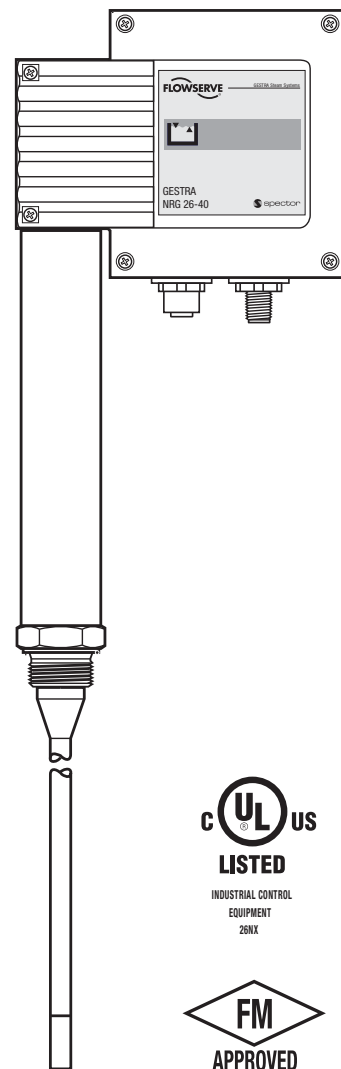
Prefabricated control cable (with connector and coupler) of various lengths for connecting the equipment are available as accessories. The baud rate (data transfer rate) dictates the cable length between the bus nodes and the total power consumption of the sensor dictates the conductor size.

S 8	S 9	S 10	Baud rate	Cable length	Number of pairs and conductor size [mm <sup>2</sup> ]
OFF	ON	OFF	250 kBit/s	125 m	2 x 2 x 0.34
Factory setting					2 x 2 x 0.5
ON	ON	OFF	125 kBit/s	250 m	
OFF	OFF	ON	100 kBit/s	335 m	2 x 2 x 0.75
ON	OFF	ON	50 kBit/s	500 m	on request, dependent on bus configuration
OFF	ON	ON	20 kBit/s	1000 m	
ON	ON	ON	10 kBit/s	1000 m	

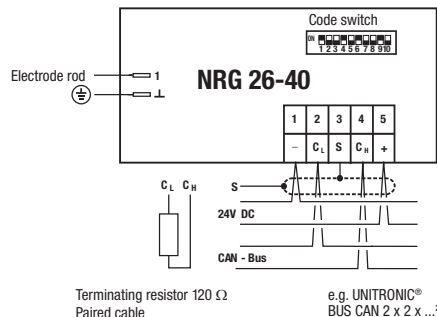
The baud rate is set via a code switch. Reduce baud rate if cable is longer than specified in the table above. Make sure that all bus nodes feature the same settings.

To protect the switching contacts fuse circuit with 2.5 A (anti-surge fuse) or according to TRD regulations (1.0 A for 72 hrs operation).

**When a max. cable length of more than 125 m (up to 1000 m) is desired, make sure to modify the baud rate accordingly.**



#### Wiring Diagram



Level Electrode  
With CAN Bus, CANopen Protocol  
Type NRG 26-40

**Technical Data** – continued –

**Electric connection**  
M 12 sensor connector, 5 poles, A-coded,  
M 12 sensor jack, 5 poles, A-coded

**Protection**  
IP 65 to DIN EN 60529

**Max. admissible ambient temperature**  
70 °C

**Weight**  
approx. 2.5 kg

**Order and Enquiry Specification**

GESTRA Level electrode type NRG 26-40  
CANopen

**Associated Level Switch/  
Level Controller**

- Level switch type NRS 2-40 CANopen
- Level controller type NRR 2-40 CANopen

**Ancillary Equipment**

- Visual display unit type URB 1, URB 2

**Key**

- A** Flange PN 40, DN 50 (2"), DIN ISO 2527  
Flange PN 40, DN 100 (4"), DIN ISO 2527
- B** For the approval of the boiler standpipe  
with connecting flange the relevant  
regulations must be considered.
- C** Vent hole
- D** High water (HW)
- E** Electrode rod d = 15 mm
- F** Protection tube DN 80 mm
- G** Electrode distance
- H** Low water (LW)
- I** Reducer K-88.9 x 3.2 – 42.4 x 2.6 W
- J** Max. length of installation at 238 °C
- K** Measuring range
- L** Adjustable control range

**ATEX (Atmosphère Explosible)**

According to the European Directive 94/9/EC the  
equipment must **not** be used in explosion-risk areas.

Supply in accordance with our general terms  
of business.

**Dimensions**

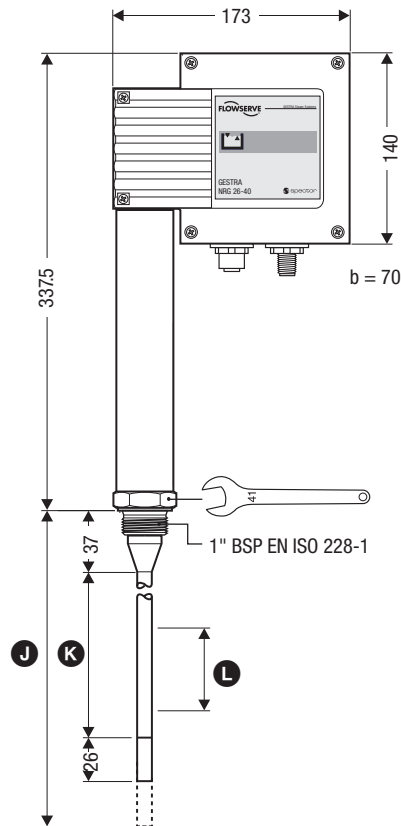


Fig. 1 NRG 26-40

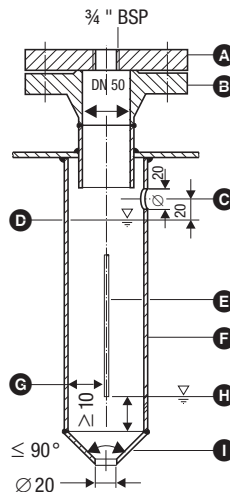


Fig. 2 Protection tube for installation  
of electrode inside the boiler

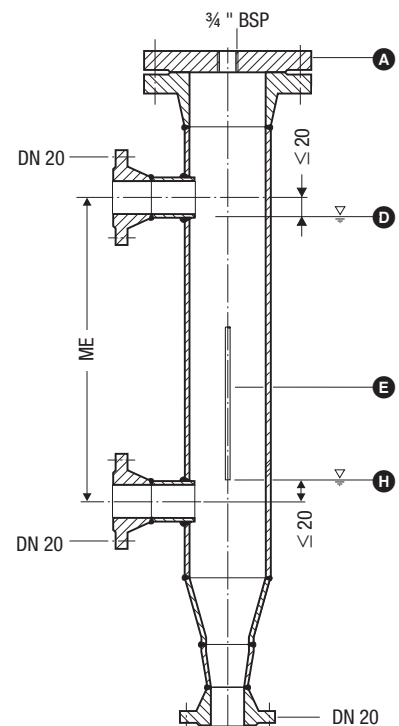
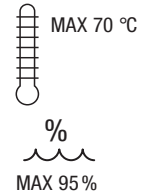


Fig. 3 External measuring pot



IP 65

CE

J	K
373	300
477	400
583	500
688	600
794	700
899	800
1004	900
1110	1000
1214	1100
1319	1200
1423	1300
1528	1400
1636	1500
2156	2000

**Flowserve GESTRA U.S.**

2341 Ampere Drive  
Louisville, KY 40299  
Tel.: 001502 / 2672205, 001502 / 2672206  
Fax: 001502 / 2665397  
Email: dgoodwin@flowserve.com



GESTRA

## GESTRA Steam Systems

## Product Range B

### Level Switch Type

### NRS 2-40

### With CAN-Bus

### NRS 2-40

#### System Description

Use level switch type NRS 2-40 in combination with level electrode type NRG 26-40 for level monitoring. The level switch has the following functions:

- Four water levels with one switchpoint each.
- High-level alarm, low-level alarm, pump ON, pump OFF, with one switchpoint each.
- Water level maintained within the control band defined by two preset limits.

The NRS 2-40 features an optional output for a standard signal 4–20 mA.

The level data are transmitted via CAN-bus from the electrode NRG 26-40 to the level switch.

#### Function

At regular intervals the level electrode type NRG 26-40 sends a data telegram to the level switch NRS 2-40. The data transfer is effected by means of a CAN bus according to DIN ISO 11898 using the CANopen protocol. The transferred measuring data are then evaluated and assigned to the switchpoints. Optionally a standard signal 4–20 mA can be allocated for external level indication. The de-energizing delay of the relay can be manually adjusted with the aid of the control terminal and display unit URB 1.

To guarantee the correct functioning and safety of the system the data transmitting cycle of the level switch is constantly monitored. When the CAN bus line is interrupted the level switch sends a visual signal to indicate a malfunction and the relays 1 and 4 will be instantaneously de-energized (fail safe position).

#### Design

##### NRS 2-40 b

Enclosure of insulating material with box terminals for installation in control cabinets. The terminals are externally accessible.

Clipping onto a standardized supporting rail TS 35 x 15 DIN EN 50022.

External dimensions: 100 x 73 x 118 mm

#### CAN-Bus

All level and temperature switches, controllers and electrodes are interconnected by means of a CAN bus. The data exchange is effected by means of a CAN bus according to DIN ISO 11898 using the CANopen protocol. Every item of equipment features an electronic address (Node ID). The four-core bus cable serves as power supply and data highway for high-speed data exchange.

NRS 2-40 is configured at our works and ready for service with other GESTRA components.

NRS 2-40 can be used straight away without having to set the node ID.

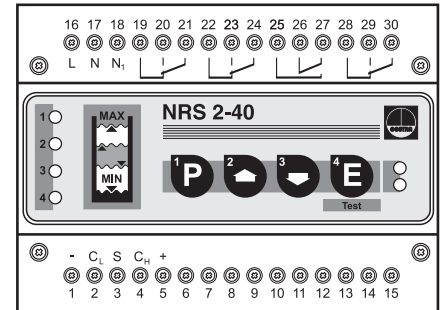
#### First and Second Control Equipment

It is possible to operate the level switch NRS 2-40 together with a **second** level switch NRS 2-40 when **8 instead of only 4 switchpoints** are required. The second level switch is termed **“second control equipment”** and must be ordered separately.

The NRS 2-40 (1st control equipment) can also be operated together with **level controller NRR 2-40** as **“second control equipment”**.

The standard equipment NRS 2-40 is designated **“first control equipment”**.

If you have any queries concerning the information included in this data sheet, please do not hesitate to contact our technical department.



#### Important Note

Note that screened multi-core twisted-pair control cable is required, e. g. UNITRONIC® BUS CAN 2 x 2 x ...<sup>2</sup> or RE-2YCYV-fl 2 x 2 x ...<sup>2</sup>.

The baud rate (data transfer rate) dictates the cable length between the bus nodes and the total power consumption of the sensor dictates the conductor size.

S 8	S 9	S 10	Baud rate	Cable length	Number of pairs and conductor size [mm <sup>2</sup> ]
OFF	ON	OFF	250 kBit/s	125 m	2 x 2 x 0.34
<b>Factory setting</b>					
ON	ON	OFF	125 kBit/s	250 m	2 x 2 x 0.5
OFF	OFF	ON	100 kBit/s	335 m	2 x 2 x 0.75
ON	OFF	ON	50 kBit/s	500 m	on request, dependent on bus configuration
OFF	ON	ON	20 kBit/s	1000 m	
ON	ON	ON	10 kBit/s	1000 m	

The baud rate is set via a code switch. Reduce baud rate if cable is longer than specified in the table. Make sure that all bus nodes have the same settings.

To protect the switching contacts fuse circuit with 2.5 A (anti-surge fuse) or according to TRD regulations (1.0 A for 72 hrs operation).

# Level Switch Type NRS 2-40 With CAN-Bus

## Technical Data

### Type approval no.

TÜV · WR · 98-399

### Input

Interface for CAN bus to DIN ISO 11898, CANopen

### Output

Power supply 24 V DC, short-circuit proof.

Analogue output 4–20 mA (option),  
load 500 Ω for display of actual value.

4 volt-free relay contacts.

Max. contact rating with switching voltages of  
24 V AC, 115 V AC and 230 V AC: 4 A resistive,  
0.75 A inductive at  $\cos \varphi$  0.5.

Max. contact rating with a switching voltage of  
24 V DC: 4 A.

Contact material: silver, hard-gold plated.

### Interference suppression

Provide contactor with external  
RC combination (100 Ω - 47 nF)

### De-energizing delay

Output "MIN", "MAX" 3 s

### Indicators and adjusters

1 red LED for switchpoint "MAX"

1 red LED for switchpoint "MIN"

2 green LEDs for switchpoints pump ON and pump OFF

1 green LED "Power ON"

1 red LED "Bus fault"

1 ten-pole code switch for node ID and baud rate,

4 pushbuttons

### Supply voltage

230 V +/- 10%, 50/60 Hz

115 V +/- 10%, 50/60 Hz (option)

24 V +/- 10%, 50/60 Hz (option)

### Power consumption

5 VA

### Protection

Case: IP 40 to DIN EN 60529

Terminal strip: IP 20 to DIN EN 60529

### Admissible ambient temperature

0 °C to 55 °C

### Enclosure material

Front panel: polycarbonate, grey

Case: polycarbonate, black

### Weight

Approx. 0.8 kg

## Order and Enquiry Specification

GESTRA Level Switch type NRS 2-40 CANopen

Control equipment .....

Mains voltage .....V

## Ancillary Units

■ Capacitance level electrode type NRG 26-40 CANopen

■ Level switch NRS 2-40 CANopen as second control  
device for 8 switchpoints

■ Level controller NRR 2-40 CANopen as second  
control device for modulating level control

Supply in accordance with our general terms  
of business.

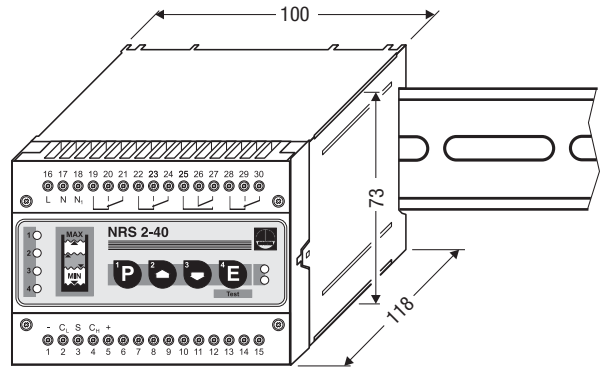
## Dimensions

MAX 55 °C

MAX 95 %

IP 20

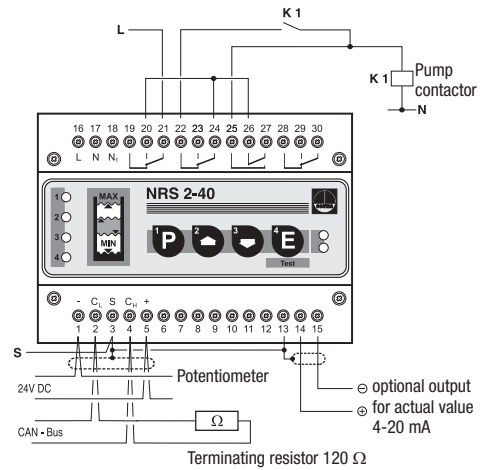
CE



## Wiring Diagram

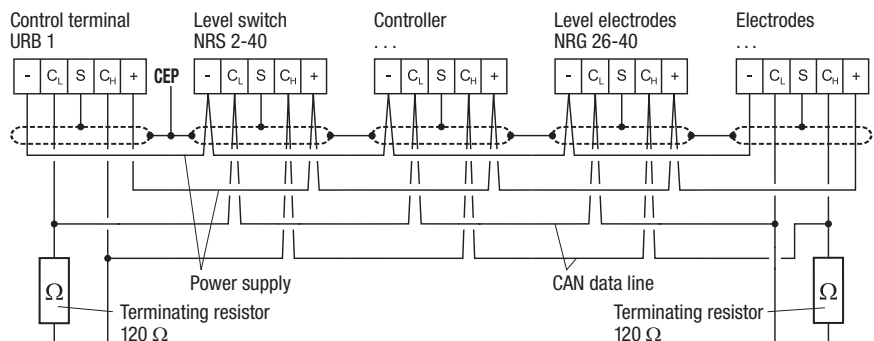
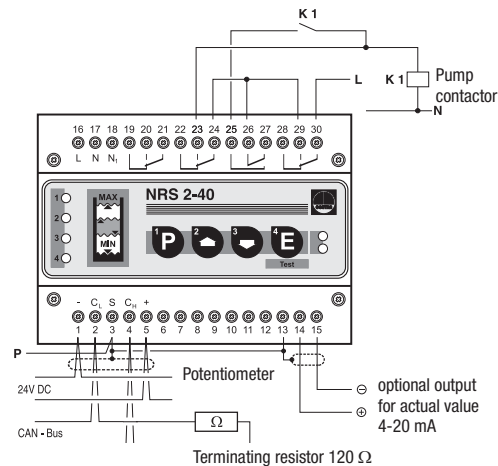
### Fill control

with High-level cut-out function



### Discharge control

with Low-level cut-out function



# Flowserve GESTRA U.S.

2341 Ampere Drive  
Louisville, KY 40299  
Tel.: 001502 / 2672205, 001502 / 2672206  
Fax: 001502 / 2665397  
Email: dgoodwin@flowserve.com



GESTRA

## GESTRA Steam Systems

## Product Range B

### Level Controller Type NRR 2-40 With CAN-Bus

### NRR 2-40

#### System Description

Use level controller type NRR 2-40 in combination with level electrode type NRG 26-40 for level control and monitoring. The level controller has the following functions:

- Two level limit values with one switchpoint each (HIGH-LEVEL alarm, LOW-LEVEL alarm)
- Three-position or modulating control within a predefined proportional band
- Water level is maintained within the control band defined by the two preset limits

The NRR 2-40 features optional outputs for standard signals 4 – 20 mA.

The level data are transferred from the electrode to the level controller or an additional system component via a CAN data bus. The controller and the electrode use the CANopen protocol.

#### Function

At regular intervals the level electrode NRG 26-40 sends a data telegram to the level controller NRR 2-40. The data are transferred via a CAN bus to DIN ISO 11898 using the CANopen protocol. The transmitted data are then evaluated and allocated to the respective control range and switchpoints. Optionally a standard signal 4 – 20 mA is established for external level indication or, when used for modulating control, for the manipulated variable Y. A relay de-energizing delay can be set manually with the control terminal and display unit URB 1.

To guarantee the correct functioning and safety of the system the data transmitting cycle of the level controller is constantly monitored. When the CAN bus line is interrupted the level switch sends a visual signal to indicate a malfunction and the relays 1 and 4 will be instantaneously de-energized (fail safe position).

#### Design

##### NRR 2-40 b

Enclosure of insulating material with terminals for installation in control cabinets. The terminals are externally accessible. Clipping onto a 35 mm standardized supporting rail (DIN EN 50022).

External dimensions: 100 x 73 x 118.

#### CAN Bus

All level and temperature switches, controllers and electrodes are interconnected by means of a CAN bus. The data exchange is effected by means of a CAN bus according to DIN ISO 11898 using the CANopen protocol. Every item of equipment features an electronic address (Node ID). The four-core bus cable serves as power supply and data highway for high-speed data exchange.

NRR 2-40 is configured at our works and ready for service with other GESTRA components.

NRR 2-40 can be used straight away without having to set the node ID.

#### Technical Data

##### Type approval no.

TÜV · WR · 03-399

##### Input

Interface for CAN bus to DIN ISO 11898, CANopen protocol  
Feedback potentiometer 1000 Ω.

##### Output

Power supply 24 V DC, conditionally short-circuit protected.

Analogue output 4 – 20 mA, load 500 Ω for display of actual value (option).

4 volt-free relay contacts.

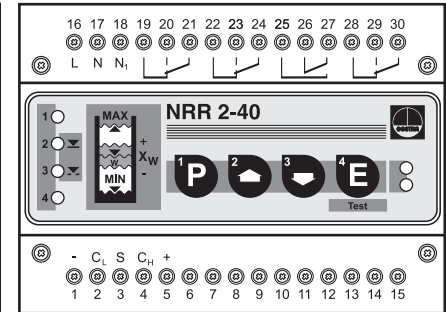
Max. contact rating with switching voltages of 24 V AC, 115 V AC and 230 V AC:

4 A ohmic, 0.75 A inductive at  $\cos \varphi 0.5$

Max. contact rating with a switching voltage of 24 V DC: 4 A.

Contact material: silver, hard-gold plated

P.T.O.



#### Important Note

Note that screened multi-core twisted-pair control cable is required, e. g. UNITRONIC® BUS CAN 2 x 2 x ...<sup>2</sup> or RE-2YCYV-fl 2 x 2 x ...<sup>2</sup>. The bus lines in the control cabinet must be used up to the control devices.

The baud rate (data transfer rate) dictates the cable length between the bus nodes and the total power consumption of the sensor dictates the conductor size.

S 8	S 9	S 10	Baud rate	Cable length	Number of pairs and conductor size [mm <sup>2</sup> ]
OFF	ON	OFF	250 kBit/s	125 m	2 x 2 x 0.34
Factory setting					
ON	ON	OFF	125 kBit/s	250 m	2 x 2 x 0.5
OFF	OFF	ON	100 kBit/s	335 m	2 x 2 x 0.75
ON	OFF	ON	50 kBit/s	500 m	on request, dependent on bus configuration
OFF	ON	ON	20 kBit/s	1000 m	
ON	ON	ON	10 kBit/s	1000 m	

The baud rate is set via a code switch. Reduce baud rate if cable is longer than specified in the table. Make sure that all bus nodes have the same settings.

To protect the switching contacts fuse circuit with 2.5 A (anti-surge fuse) or according to TRD regulations (1.0 A for 72 hrs operation).

# Level Controller Type NRR 2-40 With CAN-Bus

## Technical Data – continued –

### Interference suppression

Provide contactor with external RC combination (100 Ω-47 nF) or according to the specification of the valve manufacturer.

Analogue control output for manipulated variable 4 – 20 mA, max. load 500 Ω (option).

### Relay de-energizing delay

Output “MIN”, “MAX” 3s (set at the factory).

### Indicators and adjusters

- 1 red LED for switchpoint “HIGH LEVEL”
- 1 red LED for switchpoint “LOW LEVEL”
- 2 green LEDs for deviation “X<sub>w</sub> LOW LEVEL” and “X<sub>w</sub> HIGH LEVEL”
- 1 green LED “Power”
- 1 red LED “Bus fault”
- 1 ten-pole code switch for node ID and baud rate
- 4 pushbuttons

### Control response

P-controller as continuous or three-position stepping controller

### Proportional band X<sub>p</sub>

1 % to 100 %

### Position feedback Y<sub>p</sub>

0 Ω to 1000 Ω

### Switching range (dead band) X<sub>sh</sub>

3 %

### Supply voltage

- 230 V +/- 10 %, 50/60 Hz
- 115 V +/- 10 %, 50/60 Hz (option)
- 24 V +/- 10 %, 50/60 Hz (option)

### Power consumption

5 VA

### Protection

- Enclosure: IP 40 to DIN EN 60529
- Terminal strip: IP 20 to DIN EN 60529

### Admissible ambient temperature

0 °C to 55 °C

### Enclosure material

- Front panel: polycarbonate, grey
- Enclosure: polycarbonate, black

### Weight

Approx. 0.8 kg

## Order and Enquiry Specification

GESTRA Level Controller type NRR 2-40 CANopen

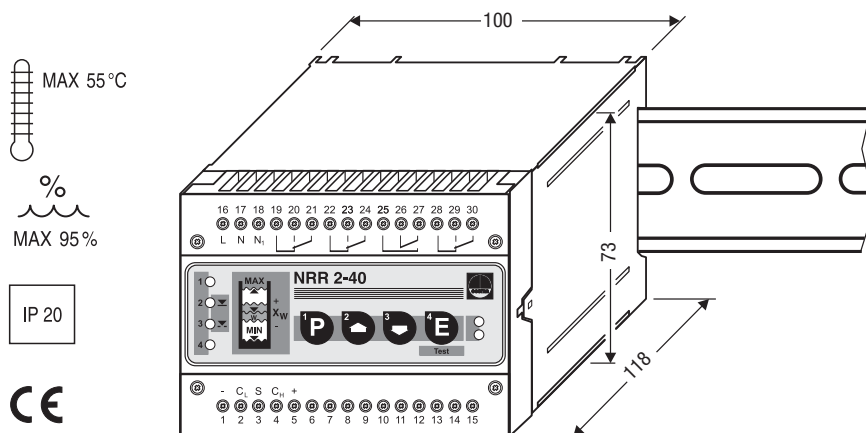
Mains voltage .....V

## Ancillary Units

- Capacitance level electrode type NRG 26-40 CANopen
- Control terminal and display unit type URB 1 CANopen

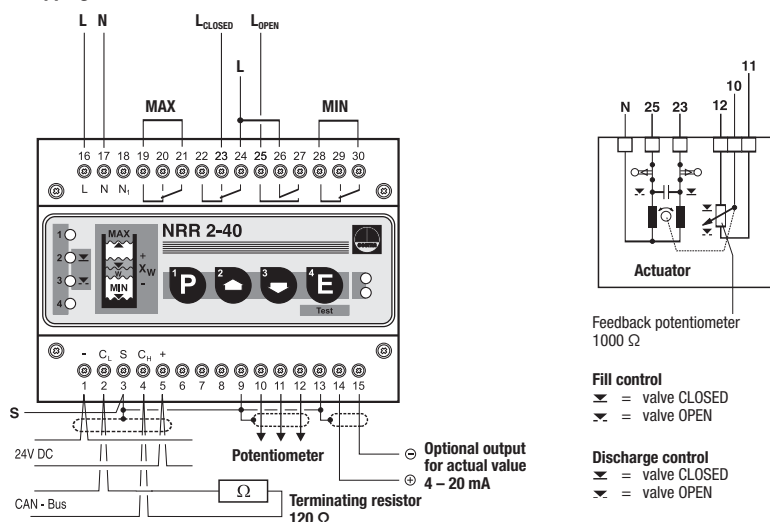
Supply in accordance with our general terms of business.

## Dimensions

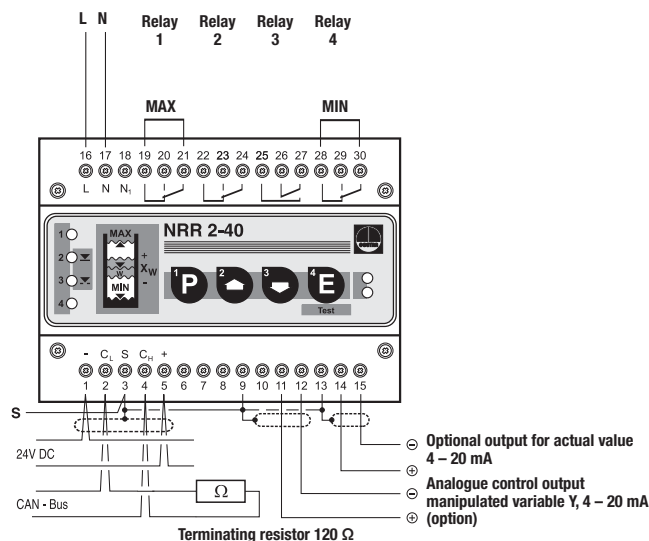


## Wiring Diagram

### Three-position stepping controller



### Continuous controller



# Flowserve GESTRA U.S.

2341 Ampere Drive  
Louisville, KY 40299  
Tel.: 001502 / 2672205, 001502 / 2672206  
Fax: 001502 / 2665397  
Email: dgoodwin@flowserve.com



GESTRA



## GESTRA Steam Systems

Product Range B1

Level Probes

**NRG 21-11, NRG 21-51**

**NRG 21-11**

**NRG 21-51**

### Purpose and Application

Completely insulated rod-type/rope-type probes for level control of vessels with liquids or granular products not prone to form deposits.

Depending on the electronic units connected the following applications are possible: Modulating or on-off fill or discharge control, high and low-level alarms and remote level indication.

Application in conductive and dielectric media. A modification of the dielectric constant  $\epsilon$  or a mixture of fluids with different dielectric constants is not admissible.

### Design

The level probes are provided with a steel rope completely covered by plastics. The rope forms one plate of a capacitor, the earth plate being the vessel wall or the earth rope.

A preamplifier fitted in the terminal box produces the measuring frequency and evaluates the capacitance which is a function of the level.

#### NRG 21-11

The two ends of the rod are pressure-tight and electrically insulated. A pressure-balancing system between measuring rod and terminal box enables the probe to be used in a steam atmosphere under pressure.

#### NRG 21-51

The two ends of the rope are pressure-tight and electrically insulated by a system of O-rings made of FKM or EPDM. The vertical position of the rope in the vessel is ensured by a weight.

### Versions

Rod-type/rope-type probe NRG 21-... with screwed connections, 1 1/2" BSP (1 1/2" NPT on request)

### Operation

A high-frequency oscillator in the terminal box of the probe fed from the connected electronic unit produces a current flow between measuring rod and vessel wall. The current varies with the depth of immersion of the probe, i.e. proportional to the level, and is rectified for transmission to the connected electronic unit.

### Technical Data

#### Installation

Inside the vessel

#### Max. service pressure

6 barg (85 psig)

#### Media

Conductive and dielectric liquids, non-abrasive, granular products

#### Connection

NRG 21-... PN 6, screwed 1 1/2" BSP, DIN 228 (NPT on request)

#### Control range H

max. length L see "Dimensions"

#### Max. permissible ambient temperature

at terminal box

60 °C

#### Wiring

Four-pole connector with screw terminals, cable strain relief and cable gland Pg 11

#### Supply voltage

12 V, 3mA

#### Output voltage

0-7 V DC

#### NRG 21-11

##### Materials

Body: XCrNiMoTi 18 10 (1.4571)

Rod: X5CrNi 18 10 (1.4301)

Insulating tube: PTFE

##### Max. service temperature

164 °C

##### Approx. weight

1.4 kg

#### NRG 21-51

##### Materials

Body: XCrNiMoTi 18 10 (1.4571)

Flange: C22-8 (1.0460)

Rope: X5CrNiMo 18 10 (1.4401) / FEP

O-ring system FKM, e.g. mineral oil, lye, dyebaths up to 160 °C, water up to 100 °C

O-ring system EPDM, e.g. water up to 140 °C

##### Max. service temperature

O-ring system FKM 160 °C

O-ring system EPDM 140 °C

##### Approx. weight

2.1 kg

### Important Notes

Recommended cable for wiring: Screened cable, e.g. 4 x 0.50<sup>2</sup>, max. cable length 100 m.

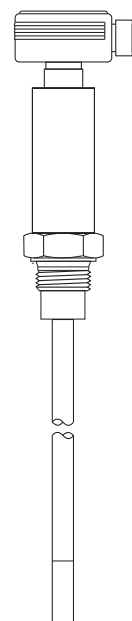
If, over the complete length of the measuring rod / rope, the distance to the vessel wall is not constant or if the vessel wall is not made of metal an earth electrode (earth rope, protection-tube) has to be provided.

#### NRG 21-11

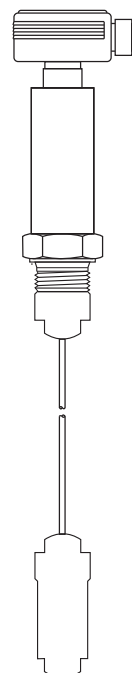
When installing probe consider thermal expansion of measuring point (see "Dimensions").

#### NRG 21-51

If the liquid is strongly agitated (for example owing to the use of agitators or near a pump inlet or outlet), axial guiding of the weight is necessary (see "Installation and Service Instructions").



NRG 21-11



NRG 21-51

## Level Probes NRG 21-11, NRG 21-51

### Order and Enquiry Specifications

GESTRA level probe for modulating or on-off level control with the GESTRA electronic units for evaluation:

Level probe (rod-type/rope-type)

type NRG 21-...

PN 6,

connection.....

control range H..... mm

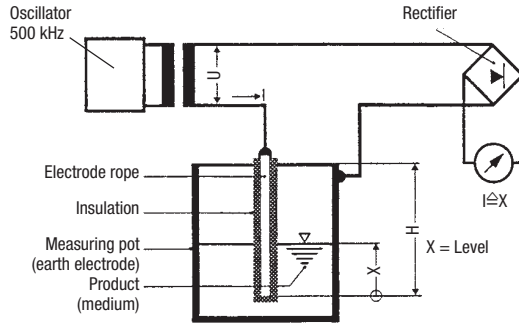
medium.....

**The following test certificates can be issued on request, at extra cost:**

In accordance with DIN EN 10204-2.1,-2.2 and -3.1B. All inspection requirements have to be stated with the order. After supply of the equipment certificates can no longer be established. Charges and extent of the above mentioned certificates as well as the different tests confirmed therein are listed in our leaflet "Test and Inspection Charges for Standard Equipment". For other tests and inspections than those listed above, please consult us.

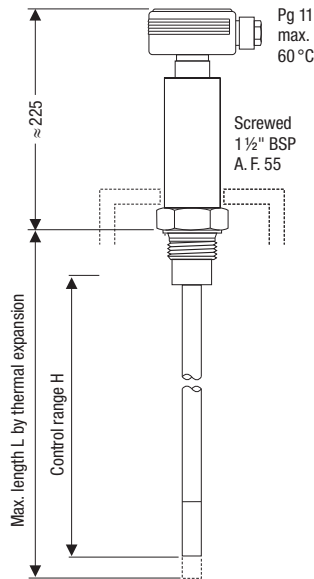
### Associated Equipment

- Level controller type NRR 2-1b as three-position stepping controller with proportional action
- Max.-min. limit switch type NRS 2-1b for MAX and MIN alarms
- Level transmitter type NRT 2-1b with current output 0 to 20 mA or 4 to 20 mA
- Level indicator type URA with LED analogue display
- Level controller type NRR 2-20 (fill or discharge control) as three-position stepping controller with proportional action, with additional signal output for high and low level alarms and current output 0/4 to 20 mA for remote level indication
- Electric/pneumatic control valves type Fox Pak

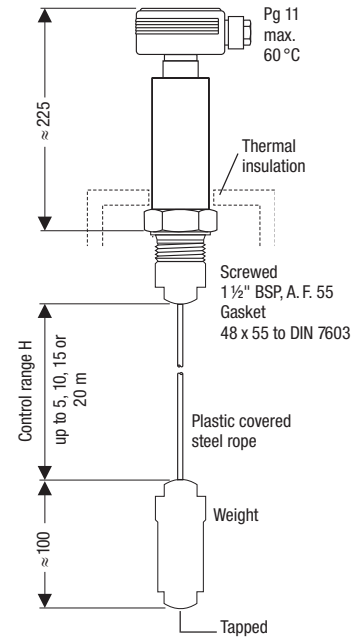


Schematic diagram of level probes type NRG 21-...

### Dimensions



Level probe type NRG 21-11



Level probe type NRG 21-51

Control range H	Max. length L by thermal expansion
300 mm	349 mm
400 mm	454 mm
500 mm	559 mm
600 mm	663 mm
700 mm	768 mm
800 mm	873 mm
900 mm	978 mm
1000 mm	1083 mm
1500 mm	1607 mm
2000 mm	2130 mm

Supply in accordance with our general terms of business.

## Flowserve GESTRA U.S.

2341 Ampere Drive  
Louisville, KY 40299  
Tel.: 001502 / 2672205, 001502 / 2672206  
Fax: 001502 / 2665397  
Email: dgoodwin@flowserve.com



GESTRA

## GESTRA Steam Systems

Product Range B1

### Level Probe NRG 26-21

### NRG 26-21

#### Description

The compact system NRG 26-21 works according to the capacitance measurement principle. The NRG 26-21 is used for signalling different levels in electrically conductive and non-conductive liquids:

- Water level maintained within the control band defined by two preset limits.

The NRG 26-21 works with various GESTRA electronic devices.

#### Function

The principle of capacitance measurement is applied to determine the level. The electrode rod and the vessel wall form a capacitor. If the level of the dielectric located between these two capacitor plates changes, the current which flows through the plates changes proportionally to the level. A dielectric is by definition an insulating substance, which excludes many liquids such as water. In order to receive a useful measuring result the measuring rod, which is submerged to varying depths in the liquid, must be completely insulated. After the calibration of the zero point/measuring range (0% – 100%) of the control unit, the level can be read off from a remote display unit. The level measuring range can be changed during operation.

#### Design

Screwed 3/4", EN ISO 228-1

#### Technical Data

##### Type approval no.

NRG 26-21: TÜV · WR · 01-320

NRG 26-21: TÜV · WR/WS · 04-317

##### Service pressure

32 bar g at 238 °C

##### Connection

NRG 26-21: Screwed 3/4", EN ISO 228-1

##### Materials

Terminal box: PPO (Noryl®)

Stem: 1.4571 CrNiMoTi17-12-2

Measuring electrode: 1.4571 CrNiMoTi17-12-2

Electrode insulation: PTFE

##### Supply voltage

12 V

##### Overall length / measuring range

See table overleaf.

##### Cable entry

Cable gland with integral cable clamp M16 (PG 9)

##### Protection

IP 65 to DIN EN 40050

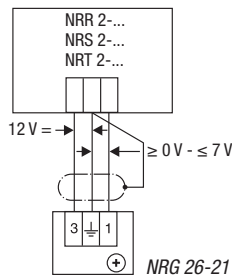
##### Max. admissible ambient temperature

Max. 70 °C

##### Weight

NRG 26-21: Approx. 5 kg

#### Wiring Diagram



#### Important Notes

Cable required for wiring to the electrode: screened four-core cable, e.g. I-Y(Sty) 2 x 2 x 0.8 or LIYCY 4 x 0.5².

Max. length 100 m.

If installed directly in a vessel or boiler, the electrode requires a protection tube DN 80/DN 100.

For external installation a level pot has to be provided into which the electrode will be mounted. The electrode should be installed verticalley.

In boiler plants of the company Th. Loos, Gunzenhausen, the electrode can be installed at an inclination of not more than 45 ° from the vertical. However, the electrode length must not exceed 650 mm. Note that combination electrodes have to be installed vertically.

When installing the electrode make sure that there is a spacing of at least 40 mm between the electrode and the upper vent hole.

If the electrode is installed into a plastic coated or plastic vessel, a reference electrode (earth) has to be provided!

#### Order and Enquiry Specifications

##### GESTRA Level Probe NRG 26-21, PN 40

Connection.....

Inspection.....

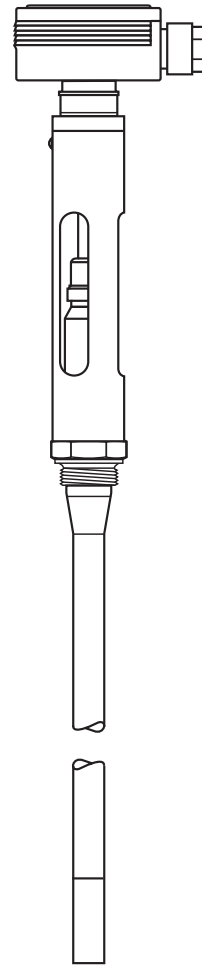
Length supplied..... mm

Fluid .....

**The following test certificates can be issued on request, at extra cost:**

In accordance with EN 10204-2.1, -2.2 and -3.1 B.

All inspection requirements have to be stated with the order. After supply of the equipment certification cannot be established. For tests and inspection charges, please consult us.



NRG 26-21

## Level Probe NRG 26-21

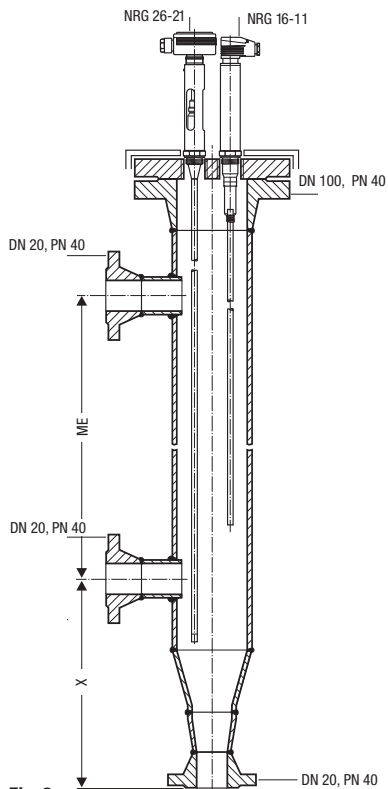
### Associated Electronic Control Units

- Level controller type NRR 2-1 as three-position stepping controller with proportional action
- Max.-min. limit switch type NRS 2-1 for MAX and MIN alarms
- Level transmitter NRT 2-1 with current output 4 to 20 mA
- Level controller type NRR 2-2 as proportional controller and combination equipment

### Ancillary Equipment

- URA with LED analogue display

### Examples of Installation

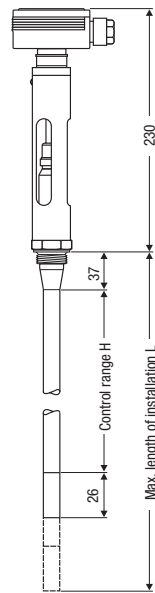


**Fig. 2**

Level pot XIII-40 for combination electrode type NRG 16-37 Control range  $H = ME + 190 \text{ mm}$ , "X" = variable ( $ME = \text{centre distance}$ ).

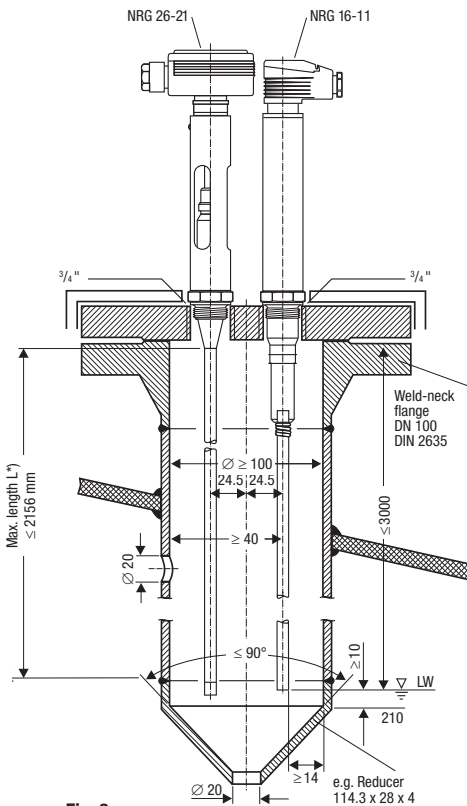
Supply in accordance with our general terms of business.

### Dimensions



**Fig. 1**

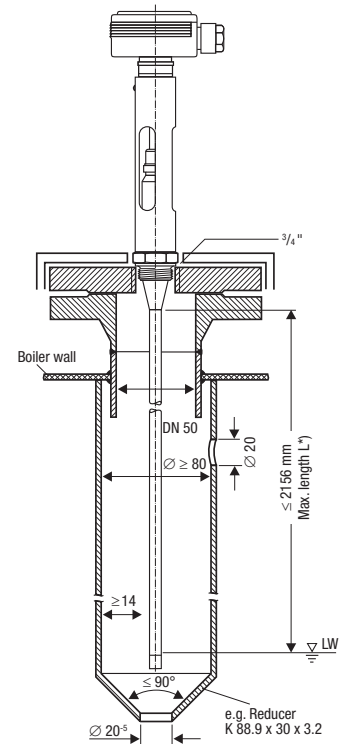
Control range H	Length L at 238 °C
300	373
400	477
500	583
600	688
700	794
800	899
900	1004
1000	1110
1100	1214
1200	1319
1300	1423
1400	1528
1500	1636
2000	2156



**Fig. 3**

Protection tube for combination electrode installed inside the boiler

\*) refer to table next to **Fig. 1**



**Fig. 4**

Protection tube, if probe NRG 26-21 is installed inside the boiler

\*) refer to table next to **Fig. 1**

## Flowserve GESTRA U.S.

2341 Ampere Drive  
Louisville, KY 40299  
Tel.: 001502 / 2672205, 001502 / 2672206  
Fax: 001502 / 2665397  
Email: dgoodwin@flowserve.com



GESTRA

## GESTRA Steam Systems

Product Range B1

### Three-Element Controller NRZ 2-1

### NRZ 2-1

#### System Description

Three-element control in conjunction with GESTRA level controller type NRR 2-... and GESTRA vortex flow meters for steam and feedwater. The system minimises the effect to steam-boiler level controls caused by a sudden high steam demand resulting in rapid expansion of the boiler water.

Application in steam boiler plants of group 2 and 4 (Steam Boiler Regulations).

#### Function

The three-element controller type NRZ 2-1 is used with a feedwater control system which consists of a level probe type NRG 26-... and a level controller type NRR 2-..., and steam and feedwater flow meters to form a three-element control. For this purpose the level in the boiler, and the steam and feedwater flowrates are measured and converted into standard electrical signals. The NRZ 2-1 compares the signals received from the steam and feedwater flow meters and calculates the difference. With the aid of an adjustable potentiometer on the front of the NRZ 2-1 the influence of the steam and feedwater flowrates can be incorporated into the operating conditions. The difference between these is subtracted from the signal received from the level probe, and an adjusted actual value is formed, which is then transmitted to the level controller type NRR 2-... The system therefore corrects the response of the controller which would otherwise have reacted to the artificial high level in the boiler due to rapid expansion of the water caused by sudden high steam demand.

#### Design

Plug-in unit in plastic case for installation in control cabinets. The terminals in the case are accessible after loosening two screws and unplugging the unit from its base.

The plug-in unit may be snapped onto a 35 mm supporting rail or screwed into position on a mounting panel.

Field enclosures for several plug-in units are available on request.

#### Technical Data

##### Inputs

##### 1. Steam flow meter

Stabilized current input 0 to 20 or 4 to 20 mA, max. load 56 ohm.

##### 2. Feedwater flow meter

Stabilized current input 0 to 20 or 4 to 20 mA, max. load 56 ohm.

Input signal filtering for 1 and 2  $\leq$  230 V amplitude.

##### 3. Boiler level control

From level probe type NRG 26-... with pre-amplifier type NRV 2-8 or NRV 2-29, voltage input 0.5 to 7 V d.c.

##### Output

To level controller type NRR 2-..., voltage output 0.5 to 7 V d.c.

##### Indicators and adjusters

One potentiometer for establishing differential between steam and feedwater flowrates.

One service switch for commissioning.

##### Supply voltage

12 V d.c. from level controller type NRR 2-...

##### Protection

IP 40 to DIN EN 40050

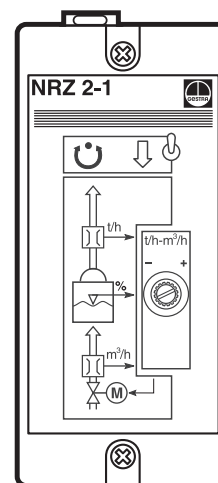
##### Permissible ambient temperature

0 °C to 55 °C

##### Case materials

Base: ABS plastic, black

Cover: Polystyrene (highly shock resistant), stone grey



## Three-Element Controller NRZ 2-1

### Important Notes

Cable required for wiring to the electrode: Four-core overall screened cable, e.g. I-Y(St)Y 2x2x0.8 or LIYCY 4x0.5. min. conductor size 0.5 mm<sup>2</sup>.

Max. cable length 100 m.

When mounting the electrode into steam boilers the relevant regulations must be considered.

### Order and Enquiry Specifications

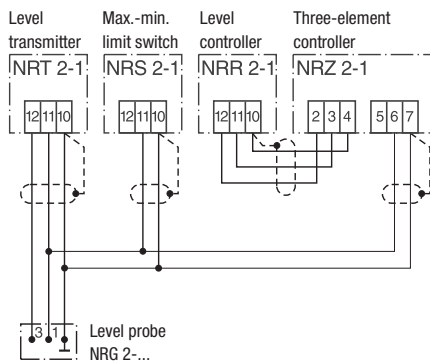
GESTRA three-element controller type NRZ 2-1 for control of boiler plants with heavy load fluctuations.

### Associated Equipment

- Level controller type NRR 2-1
- Level controller type NRR 2-2
- Level probe type NRG 21-...
- Level probe type NRG 26-...
- Vortex flow meters

### Wiring Diagrams

Example of parallel connection of several units

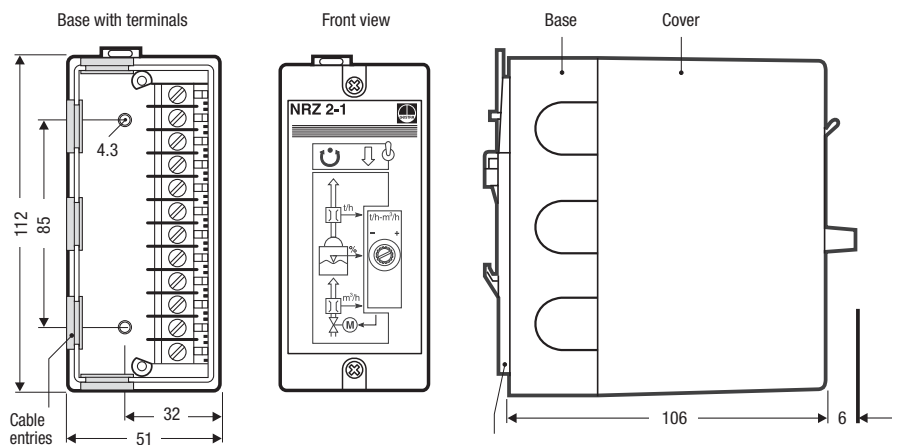


### Please note

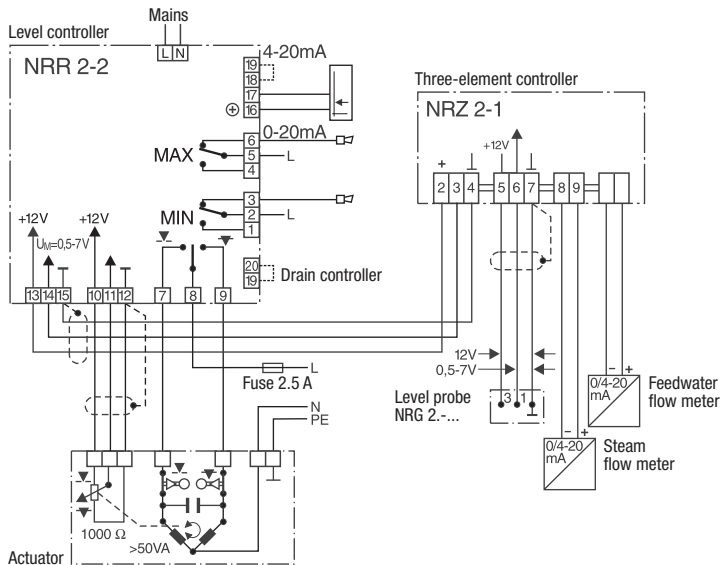
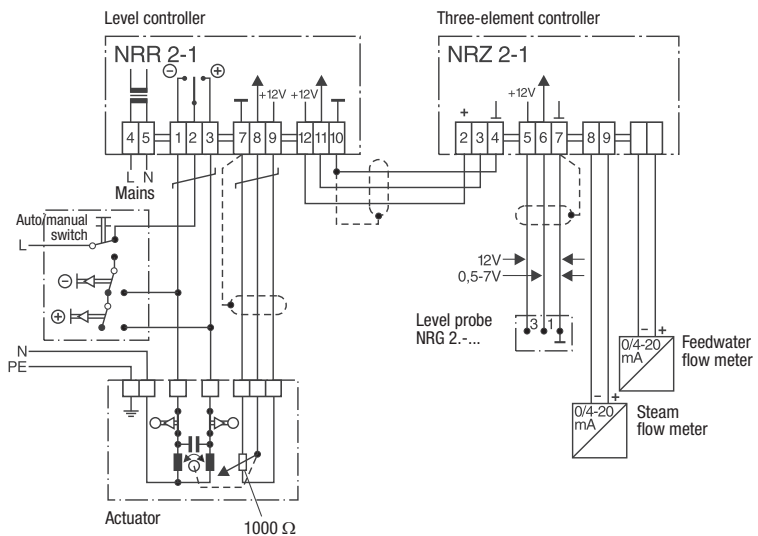
The NRZ 2-1 also evaluates the limit values and current outputs of the NRR 2-2.

Supply in accordance with our general terms of business.

### Dimensions



### Wiring Diagrams



## Flowserve GESTRA U.S.

2341 Ampere Drive  
Louisville, KY 40299  
Tel.: 001502 / 2672205, 001502 / 2672206  
Fax: 001502 / 2665397  
Email: dgoodwin@flowserve.com



GESTRA

## GESTRA Steam Systems

Product Range B1

### Max.-Min. Limit Switch NRS 2-1b

### NRS 2-1

#### Description

Signalling of two continuously adjustable limit values as MAX and MIN alarms (high and low-level alarms) with the GESTRA level probe type **NRG 21** or type **NRG 26**.

Application in steam boilers, condensate and other tanks.

#### Design

Plug-in unit in plastic case for installation in control cabinets. The terminals in the case are accessible after loosening two screws and unplugging the unit from its base. To avoid confusion with other plug-in units of the GESTRA range, inserts are fitted in the bases so that only the correct unit may be plugged into each base.

The plug-in units may be snapped onto a 35 mm supporting rail or screwed into position on a mounting panel.

Field enclosures for several plug-in units are available on request.

#### Technical Data

Limit switch for MAX and MIN alarms with level probe type **NRG 21** or type **NRG 26**.

#### Type-approval no.

TÜV-WR/WS-99-317

#### Input

Three connections for NRG 21 or NRG 26 or for input current 0...1 mA at 6K 8Ω.

#### Output

Two potential-free relay contacts, max. contact rating: 250 V, 500 W, 3 A ohmic with a life of  $4 \times 10^5$  switching cycles or 0.35 A inductive with a life of  $2 \times 10^6$  cycles; contact material silver, hard-gold plated.

#### Switching hysteresis

Max. - 5 %

Min. + 5 %

referred to the range between "Max" and "Min"

#### Adjustors

Two adjustors for MAX and MIN level, continuously adjustable

#### Indicators

One LED MAX alarm, one LED MIN alarm

One LED for monitoring mains supply and indicating operating errors

#### Mains supply

24 V/50 ... 60 Hz, 120 V/60 Hz, 230 V/50 Hz,

240 V/50 Hz, 2.5 VA

(please state voltage when ordering)

24 V DC supply also possible with the ancillary unit type URN-1.

#### Protection

IP 40

#### Permissible ambient temperature

0 ... 55 °C

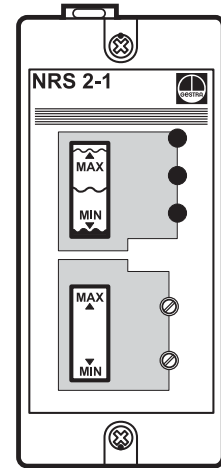
#### Case materials

Base: ABS plastic, black

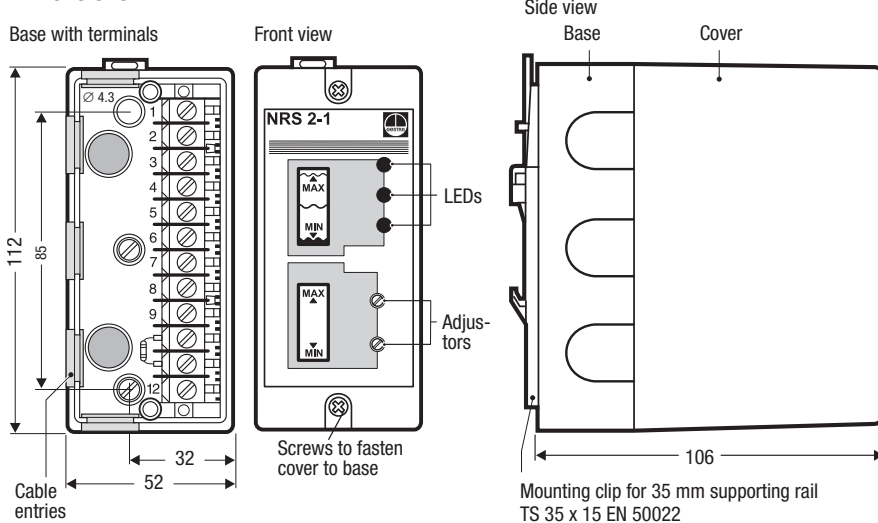
Cover: polystyrene (highly shock-resistant), stone grey

#### Approx. weight

0.5 kg

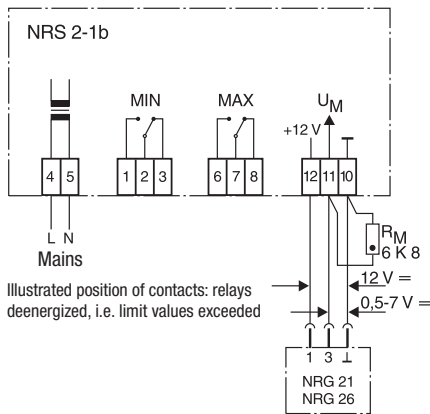


#### Dimensions

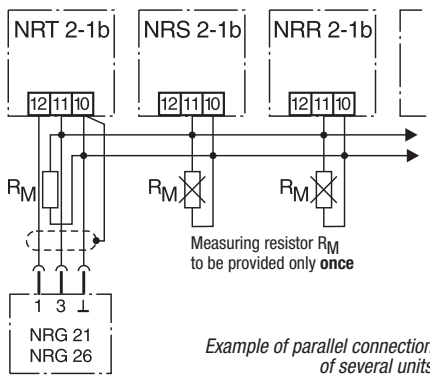


# Max.-Min. Limit Switch NRS 2-1b

## Wiring Diagrams



Wiring diagram for max.-min. limit switch type NRS 2-1b



## Important Notes

Recommended cable for wiring to the probe: Screened cable, e.g. I-Y (St) Y2 x 2 x 0.8, max. cable length 100 m. The switch contacts should be fused with 2.5 (inert fuse).

## Order and Enquiry Specifications

GESTRA max.-min. limit switch for signalling 2 limit values used with the GESTRA level probe type NRG 21 or NRG 26:

Max.-min. limit switch type NRS 2-1b, plug-in unit in plastic case for installation in control cabinets.

Mains supply..... V

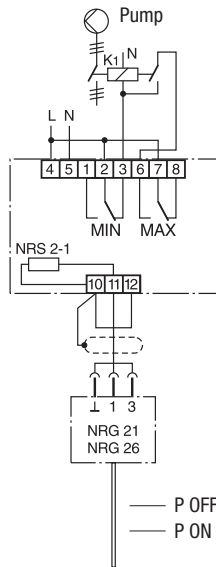
## Associated Equipment

Level controller type NRR 2-1b as three-position stepping controller with proportional action.

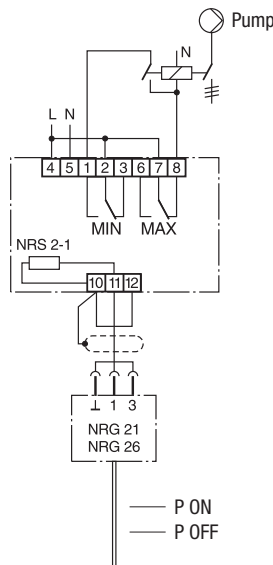
Level transmitter type NRT 2-1b with current output 0 to 20 mA or 4 to 20 mA.

Level indicator type URA with LED analogue display.

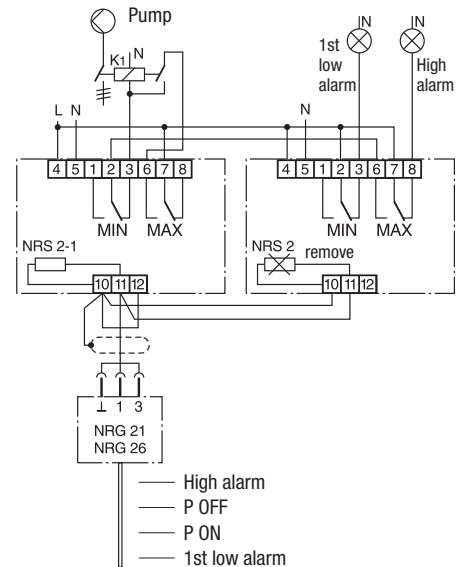
Supply in accordance with our general terms of business.



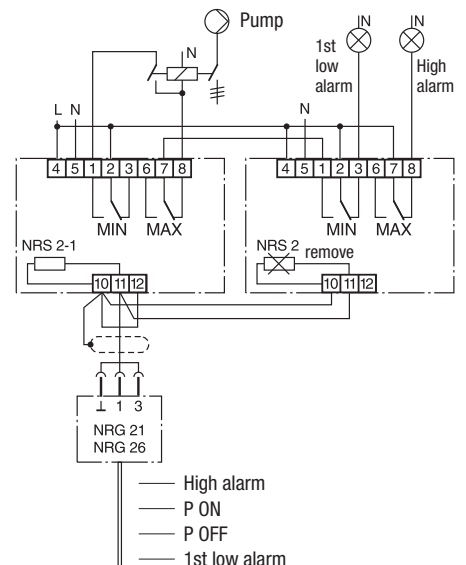
Fill control



Discharge control



Fill control with high-level alarm with EMERGENCY cut-off of pump and low-level alarm



Discharge control with high-level alarm and low-level alarm with EMERGENCY cut-off of pump

# Flowserve GESTRA U.S.

2341 Ampere Drive  
Louisville, KY 40299  
Tel.: 001502 / 2672205, 001502 / 2672206  
Fax: 001502 / 2665397  
Email: dgoodwin@flowserve.com



GESTRA



## GESTRA Steam Systems

Product Range B1

### Self-Monitoring Level-Control Electrodes NRG 16-11, NRG 17-11, NRG 19-11

**NRG 16-11**  
**NRG 17-11**  
**NRG 19-11**

#### Description

The level electrode NRG 1...-11 detects the min. liquid level (low level alarm) in a steam boiler. The operation of the electrode is based on the conductivity measuring principle using the electrical conductivity of water for signalling one liquid level:

- Low level alarm

The NRG 1...-11 is designed for use in conjunction with level switch NRS 1-7 as a self-monitoring low level limiter with periodic self-checking (SMART) feature.

Application in steam and pressurized hot-water plants in accordance with TRD 604, sheet 1 and sheet 2 (24h/72h operation) as well as EN 12952 and EN 12953.

The electrical equipment meets the requirements of the Regulations on Protection Circuits DIN VDE 0116 (prEN 50156).

#### Function

The water level limiter comprises a level electrode type NRG 1...-11 and a level switch type NRS 1-7. The level electrode NRG 1...-11 consists of two concentrically arranged electrodes (measuring electrode and compensating electrode) which are isolated from each other by special insulating seals.

The level limiter operation is based on the conductive measuring principle using the electrical conductivity of water for signalling water level. During normal, trouble-free operation the level electrode tip is immersed in boiler water and no low level alarm is given. A low level alarm will only be raised if the electrode tip is exposed for more than 3 seconds. A low level alarm will also be activated if the insulating seals placed between the electrodes and the body are no longer pressure tight, allowing water to penetrate into the cavities between the body, tube and stud. However in this instance the alarm is caused by a malfunction of the electrode, and confirmation should always be done by checking if there is water in the gauge glass. The equipment combination NRG 1...-11 and NRS 1-7 provides fail safe protection against a first fault in accordance with TRD 604.

#### System Components

##### NRS 1-7

Level switch **NRS 1-7**. Two channel level limiter (redundancy) with periodic self-checking routine to DIN VDE 0116.

#### Design

##### NRG 1...-11:

Screwed 3/4" BSP to ISO 228-1.

#### Technical Data

##### Type approval

TÜV-WB-01-354  
EG 01 202 931-B-01-0077

##### Service pressure

NRG 16-11: 32 bar at 238 °C  
NRG 17-11: 60 bar at 275 °C  
NRG 19-11: 100 bar at 311 °C

##### Connection

3/4" BSP, ISO 228-1

##### Materials

Stem 1.4571 X6CrNiMoTi17-12-2  
Measuring electrode: 1.4401, X5CrNiMo17-12-2  
Electrode insulation: Gylon®  
Terminal box: polyamide (PA)

##### Lengths available

500 mm	1000 mm
1500 mm	2000 mm
2500 mm	3000 mm

##### Cell constant C

0.13 cm<sup>-1</sup> with measuring surface extension  
0.3 cm<sup>-1</sup> without measuring surface extension

##### Response sensitivity

10 µS/cm at 25 °C, cell constant 0.3 cm<sup>-1</sup>  
0.5 µS/cm at 25 °C, cell constant 0.13 cm<sup>-1</sup>

##### Terminal box

Four-pin connector, cable gland M 16 (PG 9)

##### Protection

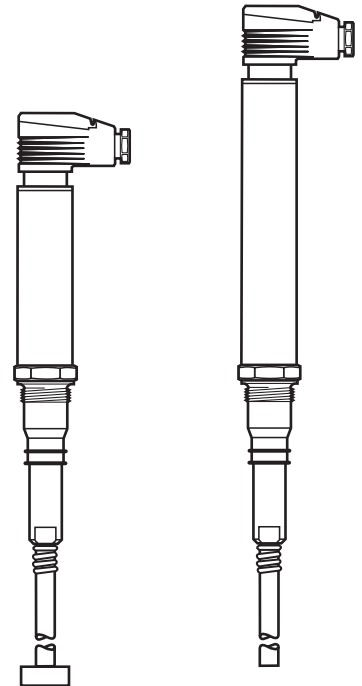
IP 65 to EN 60529

##### Max. admissible ambient temperature

Max. 70 °C

##### Weight

Approx. 1.1 kg



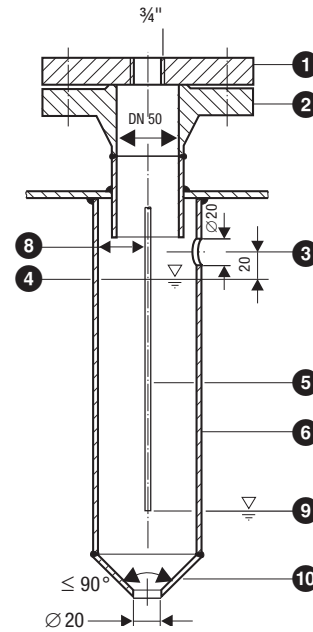
NRG 16-11 with measuring surface extension (optional)

NRG 17-11, NRG 19-11

**Key**

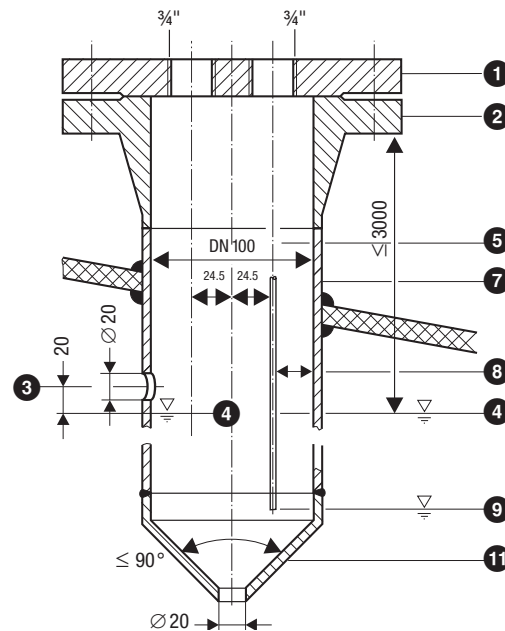
- 1 Flange PN 40, PN 63, PN 160, DN 50, DIN 2501-1  
Flange PN 40, PN 63, PN 160, DN 100, DIN 2501-1
- 2 For the approval of the boiler standpipe with connecting flange the relevant regulations must be considered.
- 3 Vent hole  
Provide vent hole as close as possible to the boiler wall!
- 4 High water (HW)
- 5 Electrode rod  $d = 8\text{ mm}$
- 6 Protection tube DN 80
- 7 Protection tube DN 100
- 8 Electrode distance  $\geq 14\text{ mm}$
- 9 Low water (LW)
- 10 Reducer DIN 2616, part 2 K-88.9 x 3.2 - 42.4x2.6 W

**Examples of Installation**



**Fig. 1**

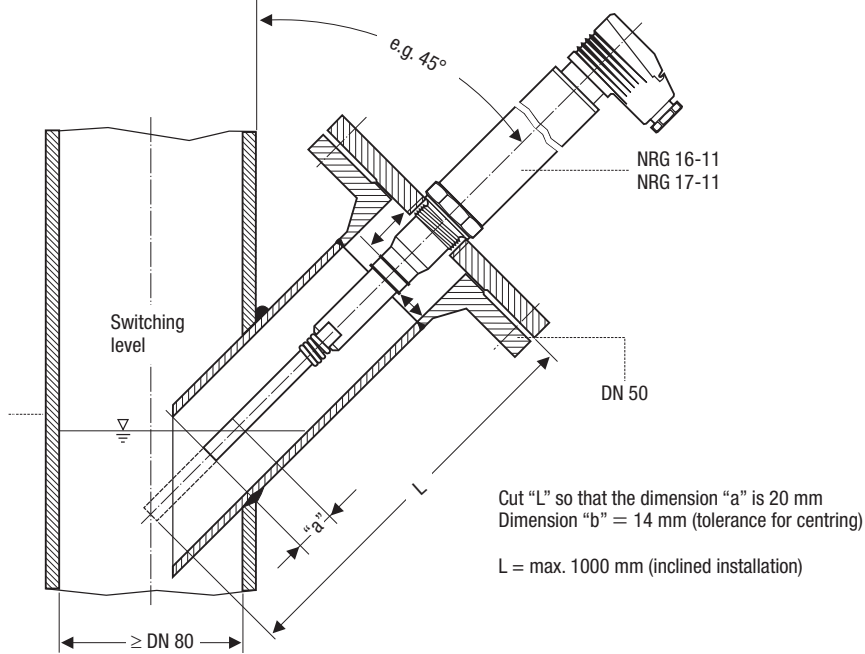
Protection tube (to be provided on site), if the electrode is installed inside the boiler, PN 40, PN 63



**Fig. 2**

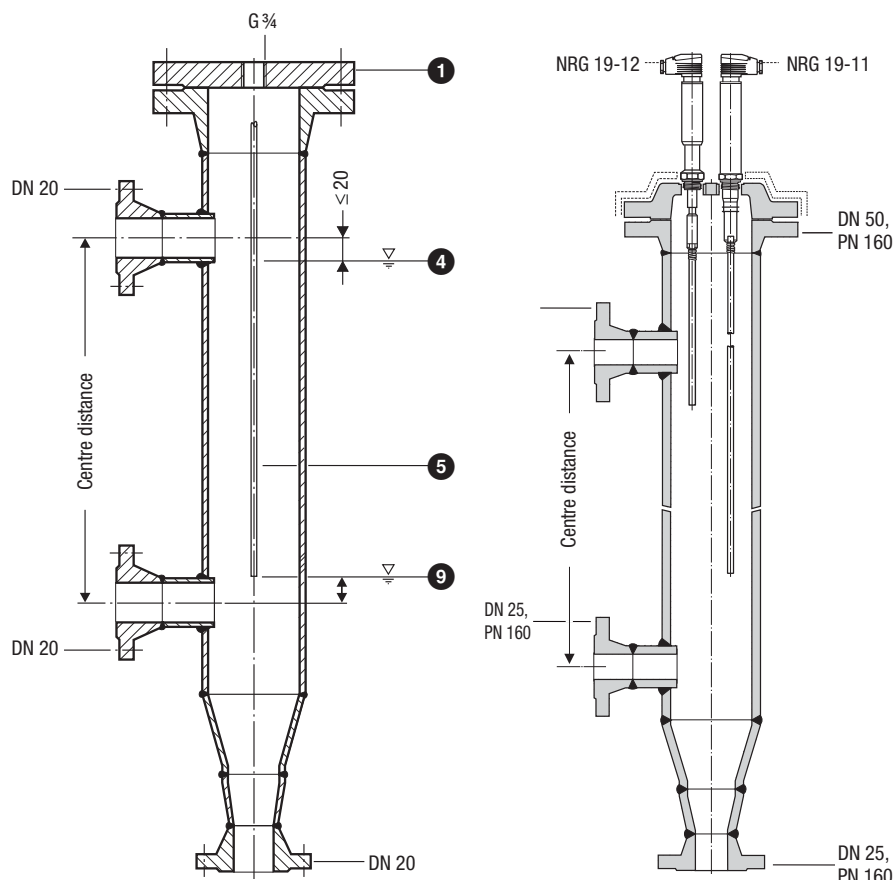
Protection tube PN 40, PN 63  
for level electrode NRG 16-11 / NRG 17-11  
combined with NRG 16-12 / NRG 17-12

## Examples of Installation



**Fig. 3**

Laterally inclined installation of electrode NRG 16-11 or NRG 17-11 in a rising feed main of a pressurized hot-water plant



**Fig. 4**

External chamber type III for installation of a low-level electrode outside of boiler, PN 160.

**Fig. 5**

External chamber type XIII for installation of two electrodes outside of boiler.

## Important Notes

Note that screened four-core cable, e.g. I-Y(St)Y 2 x 2 x 0.8 or LIYCY 4 x 0.5<sup>2</sup> is required.

Max. cable length 100 m with water conductivity from 10  $\mu$ S/cm.

Max. cable length 30 m with water conductivity from 0.5  $\mu$ S/cm.

Max. cable length 15 m with water conductivity from 0.5  $\mu$ S/cm when used in conjunction with inverter URN1 (24 V d.c.).

Provided that the electrodes are installed inside the boiler, they are unconditionally suitable for shell boilers and water-tube boilers type Thyssen-Henschel, series HK.

With other boiler types a performance test must be carried out on site when commissioning the equipment.

In this case the trouble-free interaction and correct operation of the steam boiler and the low level alarm must be approved by the competent Technical Supervisory Association (in Germany: TÜV).

The electrode shall be installed vertically or with a lateral inclination of 45°. Note: If the electrode is in an inclined position the length of the electrode must not exceed 1000 mm.

Installation directly inside the steam boiler is recommended as this provides operational and maintenance cost savings. In this case a protection tube ( $\geq$  DN 80 mm) is required.

In pressurized hot-water plants the electrode may also be installed in the feed main ( $\geq$  DN 80) in a position inclined by 45°.

When the electrode is installed inside the boiler, a protection tube I.D.  $\geq$  100 mm (Water Level 100) must be provided. According to Fig. 2 there must be a distance of at least 40 mm between the tip of the electrode and the upper vent hole.

If the electrode is installed in an external chamber, purging of the chamber is required at regular intervals. For this purpose the GESTRA logic unit for monitoring type SRL 6 is available.

## Please note

- TRD does not allow the installation of two low-level electrodes in one standpipe.
- For the approval of the boiler standpipe the relevant regulations must be considered.
- The inclination angle of the electrode must not exceed 45°. The max. length of the electrode rod is 1000 mm. Fig. 3
- If the electrode is installed outdoors, it must be provided with a weather-proof cover supplied by GESTRA.

# Self-Monitoring Level-Control Electrodes

## NRG 16-11, NRG 17-11, NRG 19-11

### Order and Enquiry Specifications

GESTRA self-monitoring level-control electrode for self-monitoring low water-level limiter according to TRD 604 and TRD 602:

- Level-control electrode type NRG 16-11.....  
 PN 40, connection .....  
 Inspection.....  
 Cell constant C .....  
 Length.....mm
- Level-control electrode type NRG 17-11.....  
 PN 63, connection .....  
 Inspection.....  
 Cell constant C .....  
 Length.....mm
- Level-control electrode type NRG 19-11.....  
 PN 160, connection .....  
 Inspection.....  
 Cell constant C .....  
 Length.....mm

The following test certificates can be issued on request, at extra cost:

In accordance with EN 10204-2.1, -2.2 and -3.1B.

All inspection requirements have to be stated with the order. After supply of the equipment certification cannot be established. For tests and inspection charges please consult us.

### Ancillary Equipment

- Logic unit type SRL 6 for monitoring purging cycles (electrode installed in external measuring pot).
- Weather-proof protective cover for outdoor installation.

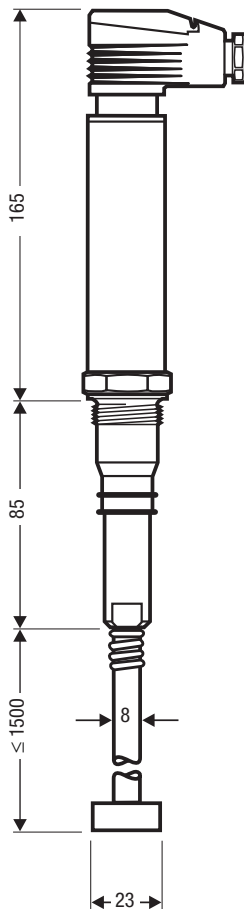
### ATEX (Atmosphère Explosible)

The equipment constitutes a simple item of electrical equipment as defined in DIN EN 50020 section 5.4. According to the European Directive ATEX 94/9/EC the equipment may only be used in potentially explosive atmospheres if it is provided with approved Zener barriers. Applicable in Ex zones 1, 2 (1999/92/EC). The equipment does not bear a CE marking. The suitability of the Zener barriers is certified in a separate document.

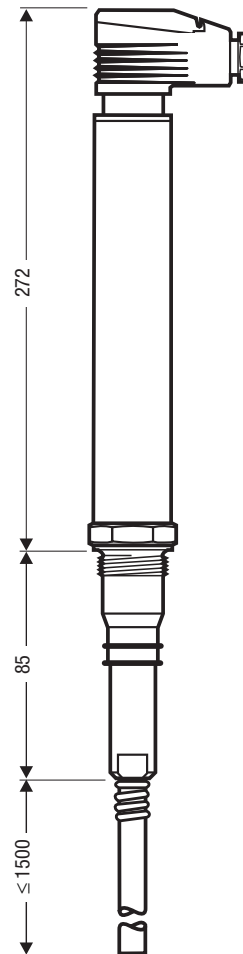
### PED (Pressure Equipment Directive)

The equipment complies with the requirements of the EC Pressure Equipment Directive 97/23/EC. NRG 16-11, NRG 17-11, NRG 19-11 are classified for application with fluids of group 2. The equipment bears the CE marking.

Supply in accordance with our general terms of business.



**Fig. 6**  
NRG 16-11 with measuring surface extension



**Fig. 7**  
NRG 17-11, NRG 19-11 without measuring surface extension

## Flowserve GESTRA U.S.

2341 Ampere Drive  
 Louisville, KY 40299  
 Tel.: 001502 / 2672205, 001502 / 2672206  
 Fax: 001502 / 2665397  
 Email: dgoodwin@flowserve.com



GESTRA

## GESTRA Steam Systems

Product Range B1

### Level Switch NRS 1-7 Self-Monitoring Low-Level Alarm with Periodic Self-Checking Routine to DIN VDE 0116

NRS 1-7



#### Purpose and Application

Self-monitoring low water-level limiter with periodic self-checking feature to be used in conjunction with the GESTRA level electrodes types NRG 16-11, PN 40, NRG 16-11S, PN 40, NRG 17-11, PN 63, NRG 19-11, PN 160 or NRG 111-11, PN 320. The equipment combination detects the low water level (low-level alarm).

The equipment meets the German regulations for use in steam-boiler plants operating in accordance with TRD 602 and TRD 604 sheet 1 and sheet 2 as well as EN 12952 and EN 12953.

#### Design

##### NRS 1-7

Plug-in unit in plastic case for installation in control cabinets. The terminals in the case are accessible after loosening two screws and unplugging the unit from its base.

To avoid confusion with other plug-in units of the GESTRA range, inserts are fitted in the bases so that only the correct unit may be plugged into each base.

The plug-in units may be snapped onto a 35 mm supporting rail or screwed into position on a mounting panel.

#### Function

The level switch type NRS 1-7 is a two-channel unit provided with an automatic self-checking circuitry in accordance with DIN VDE 0116 (directives for protection circuits). The self-checking is effected periodically. The test includes the checking of the cable between electrode and level switch and the self-checking circuitry (redundancy). The output relays are not influenced by the internal tests.

In addition to this self-checking routine, the level switch can also be tested manually by pushing the button "TEST 1" simulating a defect in the electrode. The test switch "TEST 2/INSPECTION" is provided for checking the function of the checking circuitry.

As the circuit of the relay contacts of the level switch is normally closed, alarm will also be signalled in the event of a mains failure.

The level switch can signal the following three operating conditions:

- Normal operation (correct level)
- Alarm (low level)
- Alarm (defect in level switch or electrode)

The green LED indicates mains ON. The alarm state low level or malfunction of the system is indicated by two red LEDs. The failure of one channel (loss of redundancy) is signalled by the illumination of a single red LED.

The combination of electrode NRG 16-11, NRG 16-11 S, NRG 17-11, NRG 19-11 or NRG 111-11 and level switch NRS 1-7 provides fail-safe protection against a first fault, i. e. the system will still continue to provide the safety function even after the occurrence of a first fault.

#### System Components

Level electrode NRG 16-11, PN 40, NRG 16-11S, PN 40, NRG 17-11, PN 63, NRG 19-11, PN 160, NRG 111-11, PN 320 as low-level limiter.

#### Technical Data

##### Type-approval no.

TÜV - WB - 01-354  
EG 01 202931-B-01-0077  
EG 01202931-B-01-0075

##### Input

Four terminals for the connection of one level electrode type NRG 16-11, PN 40  
type NRG 16-11S, PN 40  
type NRG 17-11, PN 63  
type NRG 19-11, PN 160  
type NRG 111-11, PN 320

##### Output

Two volt-free relay contacts (mounted in series in the case of design "b");  
max. contact rating: 250 V, 300 W, 3 A resistive with a life of  $5 \times 10^5$  switching cycles or 0.35 A inductive with a life of  $2 \times 10^6$  cycles;  
contact material silver, hard-gold plated

##### Delay of response

Set at our factory to 3 s  
(up to 25 s – TÜV approval required)

##### Sensitivity

10  $\mu\text{S}/\text{cm}$  at 25 °C when used in conjunction with level electrode without measuring surface extension (cell constant  $C = 0.3$ ).

0.5  $\mu\text{S}/\text{cm}$  at 25 °C when used in conjunction with level electrode with measuring surface extension (cell constant  $C = 0.13$ ), see data sheet NRG 16-11, NRG 111-11).

##### Indicators and adjustors

Two LEDs "Alarm"  
One LED "Operation"  
One button "TEST 1"  
One switch "TEST 2/INSPECTION"

##### Mains supply

230 V  $\pm 10\%$ , 50/60 Hz (please state voltage when ordering)

Special voltage: 115 V  $\pm 10\%$ , 50/60 Hz or

24 V  $\pm 10\%$ , 50/60 Hz;

24 V d.c. supply also possible with the ancillary unit type URN-1.

##### Power consumption

5 VA

##### Protection

Design NRS 1-7 IP 40 to EN 60529

##### Permissible ambient temperature

0 °C – 55 °C

##### Case materials

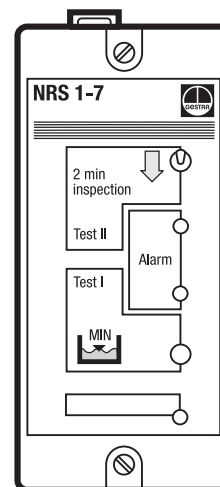
Base: Noryl SE 1-GFN 2 UL 94 VO, black

Cover: R-ABS UL 94 VO, stone grey

##### Approx. weight

0.6 kg

CE marking 0525



NRS 1-7

# Level Switch NRS 1-7 Self-Monitoring Low-Level Alarm with Periodic Self-Checking Routine to DIN VDE 0116

## Important Notes

Cable required for wiring to the electrode: four-core screened cable, e.g. I-Y(St) Y 2 x 2 x 0.8 or LIYCY 4 x 0.5<sup>2</sup>.

Max. cable length 100 m with a conductivity from 10 µS/cm.

Max. cable length 30 m with a conductivity from 0.5 µS/cm.

Max. cable length 15 m with a conductivity from 0.5 µS/cm when used in conjunction with inverter URN 1 (24 V d.c.).

When mounting the electrode into steam or pressurized hot-water boilers the relevant regulations must be considered.

The burner-protection circuit should be fused with 2.5 A anti-surge fuse or according to TRD regulations (e.g. 1.0 A for 75 hrs.)

The level switch itself is **not** interlocking. Interlocking and resetting have to be ensured on site by providing a secondary circuit (safety chain) in the control cabinet.

## Order and Enquiry Specifications

GESTRA level switch for self-monitoring low-level alarm in accordance with TRD 602, TRD 604, EN 12952 and EN 12953:

- Level switch type NRS 1-7b in a plastic case for installation in control cabinets;

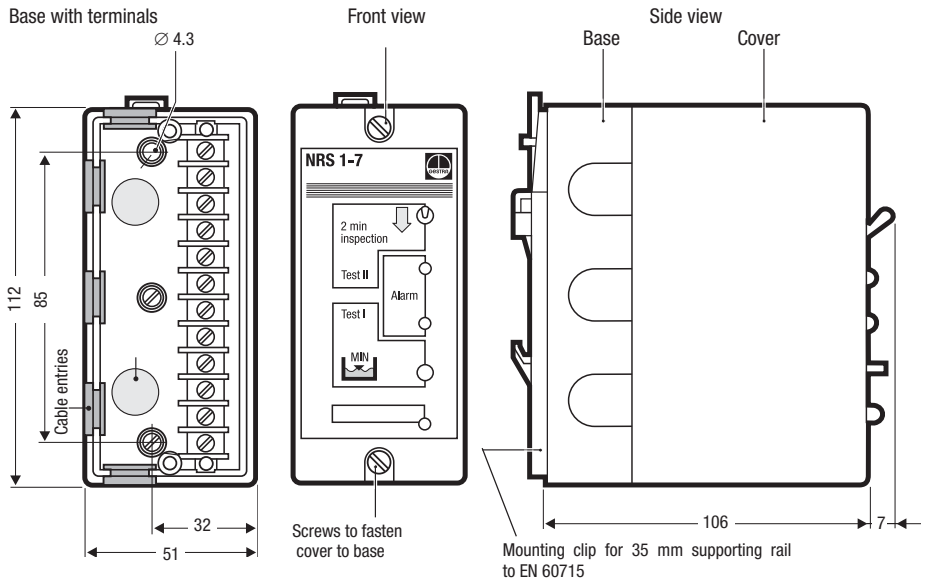
Delay of response .....s  
Conductivity .....µS/cm  
Mains supply .....V .....Hz

## ATEX

The equipment constitutes a simple item of electrical equipment as defined in DIN EN 50020 section 5.4. According to the European Directive ATEX 94/9/EC the equipment may only be used in potentially explosive atmospheres if it is provided with approved Zener barriers. Applicable in Ex zones 1, 2 (1999/92/EC). The equipment does not bear a CE marking. The suitability of the Zener barriers is certified in a separate document.

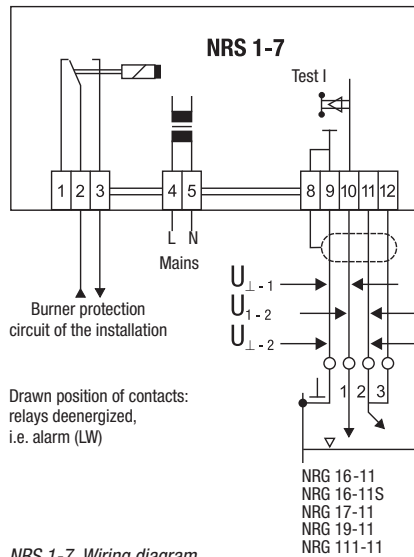
Supply in accordance with our general terms of business.

## Dimensions

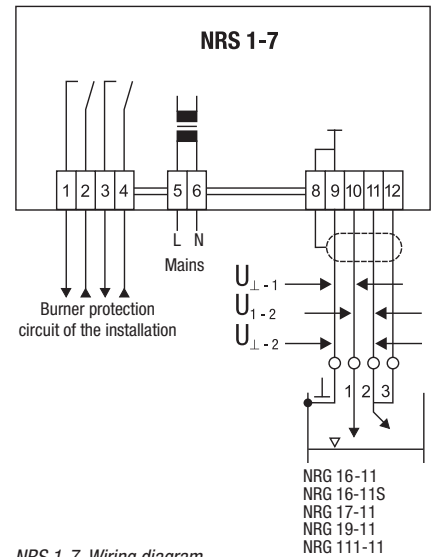


NRS 1-7b

## Wiring Diagrams



NRS 1-7 Wiring diagram  
(Europe/international)



NRS 1-7 Wiring diagram  
(France)

## Flowserve GESTRA U.S.

2341 Ampere Drive  
Louisville, KY 40299  
Tel.: 001502 / 2672205, 001502 / 2672206  
Fax: 001502 / 2665397  
Email: dgoodwin@flowserve.com



GESTRA

## GESTRA Steam Systems

Product Range B1

Level Switch

**NRS 1-8**

**Self-Monitoring High-Level Alarm with Periodic Self-Checking Routine to DIN VDE 0116**

**NRS 1-8**

### Specification

Self-monitoring high-level alarm with periodic self-checking routine, in combination with GESTRA level electrode type NRG 16-12, PN 40, NRG 17-12, PN 63, or NRG 19-12, PN 160. The equipment combination detects the max. water level (high-level alarm).

The equipment meets the German regulations for use in steam-boiler plants operating according to TRD 602 and TRD 604 sheets 1 + 2 and EN 12952 and EN 12953.

### Design

**NRS 1-8**

Plug-in unit in plastic case for installation in control cabinets. The terminals in the case are accessible after loosening two screws and unplugging the unit from its base.

To avoid confusion with other plug-in units of the GESTRA range, inserts are fitted in the bases so that only the correct unit may be plugged into each base.

The plug-in units may be snapped onto a 35 mm supporting rail or screwed into position on a mounting panel.

### Operation

The level switch type NRS 1-8 is a two-channel unit provided with an automatic self-checking circuitry in accordance with DIN VDE 0116 (directives for protection circuits). The self-checking is effected periodically. The test includes the checking of the cable between electrode and level switch and of the self-checking circuitry (redundancy). The output relays are not influenced by the internal tests.

In addition to this self-checking, the level switch can also be tested manually by pushing the button "TEST 1" simulating a defect in the electrode. The test switch "TEST 2/INSPECTION" is provided for checking the function of the checking circuitry.

As the circuit of the relay contacts of the level switch is normally closed, alarm will also be signalled in the event of a mains failure.

The level switch can signal the following three operating conditions:

- Normal operation (correct level)
- Alarm (high level)
- Alarm (malfunction in level switch or electrode)

The green LED indicates power supply. The high level or malfunction alarm is indicated by two red LEDs. The failure of one channel (loss of redundancy) is signalled by the illumination of a single red LED.

The combination of electrode NRG 16-12, NRG 17-12, or NRG 19-12 and level switch NRS 1-8 provides fail-safe protection against a first fault, i.e. the system will still continue to provide the safety function even after the occurrence of a first fault.

### System Components

Level electrode NRG 16-12, PN 40, NRG 17-12, PN 63, NRG 19-12, PN 160 as high-level alarm.

### Technical Data

**Type-approval no.**

09 - 91 - 0112

**Input**

Three terminals for the connection of one level-control electrode type

NRG 16-12, PN 40

NRG 17-12, PN 63

NRG 19-12, PN 160.

**Output**

Two volt-free relay contacts (mounted in series in the case of design "b");

max. contact rating: 250V, 300W, 3A resistive with a life of  $5 \times 10^6$  switching cycles or 0.35A inductive with a life of  $2 \times 10^6$  cycles;

contact material silver, hard-gold plated

**Delay of response**

Default factory setting: 3 s

(up to 25 s possible)

**Sensitivity**

10  $\mu\text{S}/\text{cm}$  at 25 °C when used in conjunction with level electrode without measuring surface extension (cell constant  $C = 0.3$ ).

0.5  $\mu\text{S}/\text{cm}$  at 25 °C when used in conjunction with level electrode with measuring surface extension (cell constant  $C = 0.13$ ), see data sheet NRG 16-12.

**Indicators and adjustors**

Two LEDs "Alarm"

One LED "Operation"

One button "TEST 1"

One switch "TEST 2/INSPECTION".

**Mains supply**

230 V +/- 10 %, 50/60 Hz

(please state voltage when ordering).

Special voltage: 115V +/- 10 %, 50/60 Hz or

24 V +/- 10 %, 50/60 Hz; 24 V d.c. supply also possible with the inverter type URN-1.

**Power consumption**

5 VA

**Protection**

Design NRS 1-8 IP 40 to EN 60529

**Permissible ambient temperature**

0 °C to 55 °C

**Case materials**

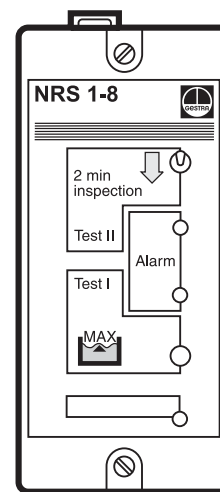
Base: Noryl SE 1-GFN 2 UL 94 V0, black

Cover: R-ABS UL 94 V0, stone grey

**Approx. weight**

0.6 kg

CE marking 0525



Level switch NRS 1-8

# Level Switch NRS 1-8 Self-Monitoring High-Level Alarm with Periodic Self-Checking Routine to DIN VDE 0116

## Important Notes

Cable required for wiring to the electrode: four-core screened cable, e.g. I-Y(St) Y 2 x 2 x 0.8 or LIYCY 4 x 0.5<sup>2</sup>.

Max. cable length 100 m with a conductivity from 10 µS/cm.

Max. cable length 30 m with a conductivity from 0.5 µS/cm.

Max. cable length 15 m with a conductivity from 0.5 µS/cm when used in conjunction with inverter URN 1 (24 V d.c.).

When mounting the electrode into steam or pressurized hot-water boilers the relevant regulations must be considered.

The burner-protection circuit should be fused with 2.5 A anti-surge fuse or according to TRD regulations (e.g. 1.0 A for 75 hrs.)

The level switch itself is **not** interlocking. Interlocking and resetting have to be ensured on site by providing a secondary circuit (safety chain) in the control cabinet.

## Order and Enquiry Specifications

GESTRA level switch for self-monitoring high-level alarm in accordance with TRD 602, TRD 604, EN 12952 and EN 12953:

- Level switch type NRS 1-8b in a plastic case for installation in control cabinets;

Delay of response .....s

Conductivity.....µS/cm

Mains supply .....V ..... Hz

# ATEX

The equipment constitutes a simple item of electrical equipment as defined in DIN EN 50020 section 5.4. According to the European Directive ATEX 94/9/EC the equipment may only be used in potentially explosive atmospheres if it is provided with approved Zener barriers.

Applicable in Ex zones 1, 2 (1999/92/EC).

The equipment does not bear a CE marking.

The suitability of the Zener barriers is certified in a separate document.

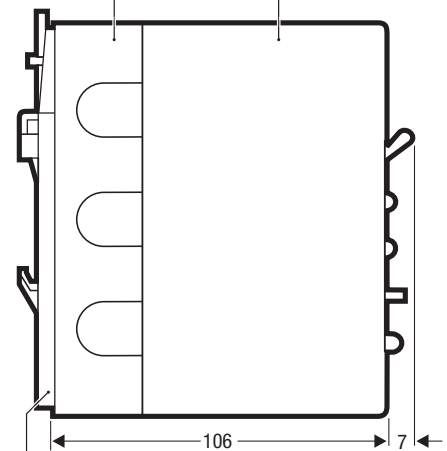
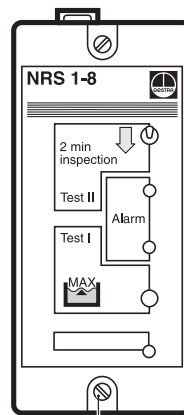
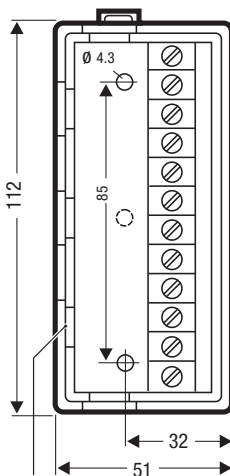
Supply in accordance with our general terms of business.

## Dimensions

Base with terminals

Front view

Side view



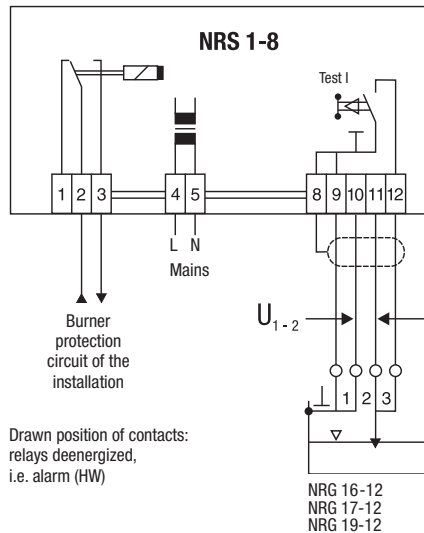
Cable entries

Screws to fasten cover to base

Mounting clip for 35 mm supporting rail TS 35, DIN 46277

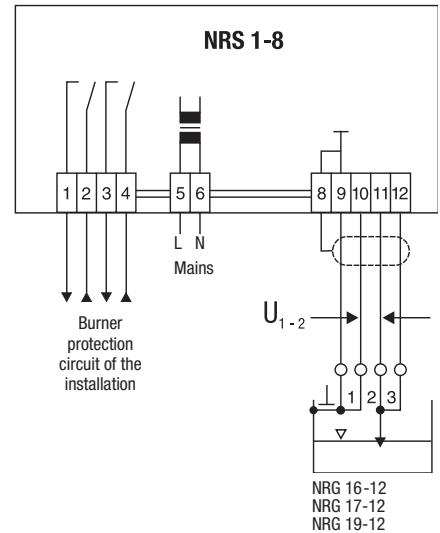
Dimensions of level switch type NRS 1-8b

## Wiring Diagrams



Drawn position of contacts: relays deenergized, i.e. alarm (HW)

Wiring diagram for NRS 1-8 (Europe/international)



Wiring diagram for NRS 1-8 (France)

# Flowserve GESTRA U.S.

2341 Ampere Drive  
Louisville, KY 40299  
Tel.: 001502 / 2672205, 001502 / 2672206  
Fax: 001502 / 2665397  
Email: dgoodwin@flowserve.com



GESTRA



## GESTRA Steam Systems

Product Range B1

### Self-Monitoring Combination Level Electrode NRG 16-36

### NRG 16-36

#### Description

Designed for use in combination with the level switch/controller NRS 1-9 as self-monitoring (SMART) water level controller/limiter with periodic self-checking routine in accordance with TRD 604, sheet 1 and 2. The equipment combination detects the max. and min. admissible liquid level and controls the level in steam and pressurized hot water plants.

TRD 604 requires two SMART water level limiters, TRD 602 requires only one SMART water level limiter.

This electrode in conjunction with the switching controller NRS 1-9 complies with the requirements of safety circuits to DIN 57116/VDE 0116.

#### Function

The switching controller operation is based on the conductive measuring principle using the electrical conductivity of the water for level signalling.

For example, when the low-level electrode tip is not in water, the bridge circuit in the switching controller NRS 1-9 becomes slightly imbalanced on the negative side, causing the output contacts to switch over to give low water-level alarm signal. When connected to the burner protection circuit, this signal is used to cut off the heat supply to the boiler.

During normal operating conditions when the low level electrode tip is immersed in water, the imbalance of the bridge circuit is on the positive side.

If the insulating seals placed between the electrodes and the body are no longer pressure-tight due to deterioration caused by mechanical or chemical breakdown, liquid will penetrate into the cavities between the body, tube and stud. This will result in a negative imbalance of the bridge circuit, and the low-level alarm signal is activated. However, in this case the alarm is caused by a malfunction of the electrode and confirmation can be obtained by checking if there is water in the gauge glass.

The effect of polarization is eliminated, as the electrode is fed with a low-voltage a.c. by the switching controller.

The self-monitoring combination electrode NRG 16-36 used in conjunction with the switching controller NRS 1-9 provides fail safe protection against a first fault (according to TRD 604), i. e. the system will still continue to provide the safety function even after the occurrence of a first fault.

#### Technical Data

##### Type approval no.

TÜV-WB-04-370

##### Service pressure

32 barg to 238 °C

##### Connections

Pressure rating PN 40, 1½" BSP, EN ISO 228-1

Pressure rating PN 40<sup>1)</sup>, DN 50, 3.1 inspection

certificate to DIN 2527

Pressure rating PN 40<sup>1)</sup>, DN 100, 3.1B inspection

certificate to DIN 2527, square flange<sup>1)</sup> □ 128, 3.1B

inspection certificate

<sup>1)</sup> Tap holes in flange acc. to DIN 3852 part 2, form X

##### Function

Low level limiter / level controller / high level limiter

##### C value with measuring surface extension

0.13 cm<sup>-1</sup>

#### Technical Data – continued –

##### Lengths supplied

400 mm

1000 mm

1500 mm

##### Materials

Body: 1.4571

Flange: 1.0460

Electrode rods: 1.4571

##### Ambient temperature at terminal box

70 °C

##### Wiring PG 9

2

##### Weight

approx. 4.5 kg

#### Important Notes

Cable required for wiring: Two four-core overall screened cables, e. g. I-Y (St)Y 2 x 2 x 0.8 or LIYCY 4 x 0.8 mm<sup>2</sup>.

Max. cable length 100 m with water conductivity from 10 µS/cm.

Max. cable length 30 m with water conductivity from 0.5 µS/cm.

Max. cable length 15 m with water conductivity from 0.5 µS/cm when used in conjunction with the inverter URN 1 (24 V d.c.).

Provided that the electrodes are installed inside the boiler, they can be used for shell boilers / water tube boilers type HK produced by Thyssen-Henschel.

If used with other types or makes of boilers the proper TÜV expert must first verify the suitability of the limiter for the boiler in question.

If the electrode is installed into a plastic-coated or plastic vessel a reference electrode (earth) has to be provided.

The electrode shall be installed vertically. To reduce costs and maintenance we recommend installation directly inside the steam boiler. In this case a protection tube (DN ≥ 100 mm) is required.

If the electrode is installed in an external chamber, purging of the chamber is required at regular intervals. For this purpose the GESTRA logic unit for monitoring type SRL 6 is available.

#### Order and Enquiry Specifications

GESTRA level electrode for water level controller and self-monitoring (SMART) water-level limiter in accordance with TRD 604 and TRD 602.

Level electrode type NRG 16-36 .....

PN 40, connection .....

Inspection .....

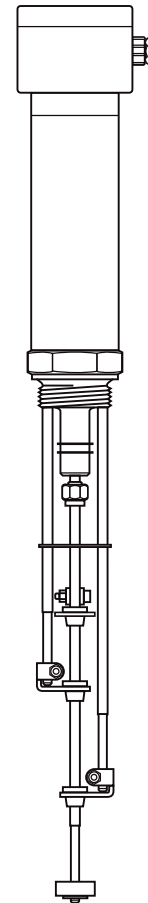
Cell constant C .....

Length .....mm

#### The following test certificates can be issued on request, at extra cost:

In accordance with EN 10204-2.1, -2.2, 3.1 and 3.2.

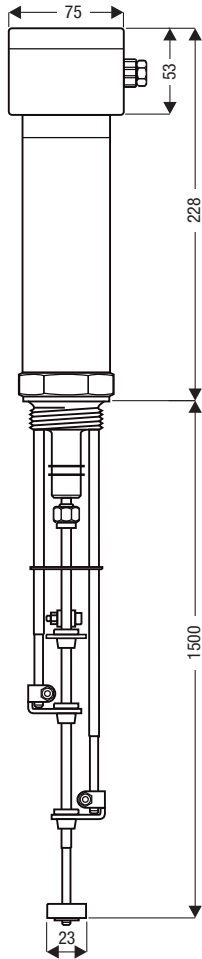
All inspection requirements have to be stated with the order. After supply of the equipment certification cannot be established. For tests and inspection charges, please consult us.



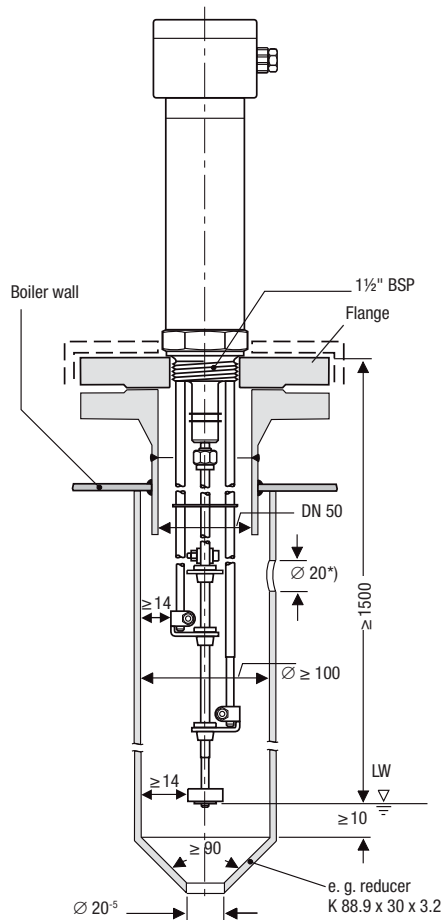
NRG 16-36

Self-Monitoring  
Combination Level Electrode  
**NRG 16-36**

**Dimensions**

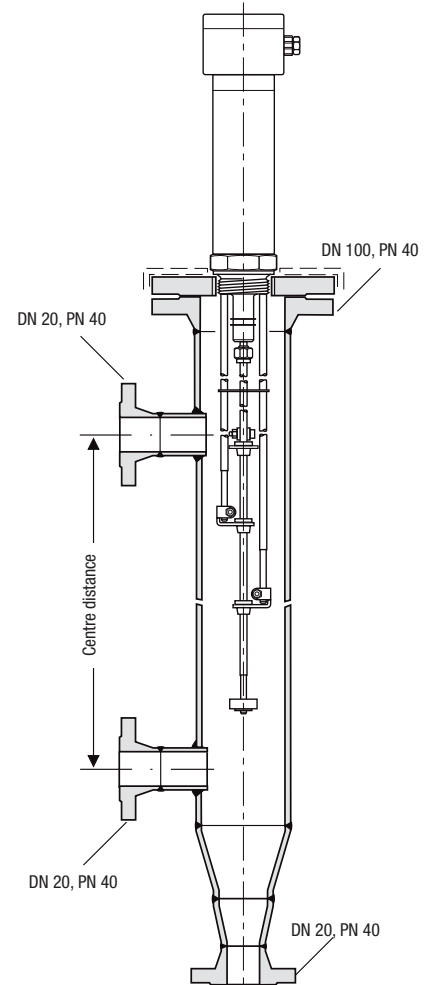


**Examples of Installation**



\*) Position vent hole as close as possible to the boiler wall

*Protection tube (to be provided on site)  
if the electrode is installed inside the boiler, PN 40*



*External chamber type XIII for installation  
of electrode outside the boiler, PN 40*

**Associated Level Switch**

Level switch NRS 1-9 as controller and two-channel (redundancy) limiter with periodic self-checking routine.

**Ancillary Equipment**

Logic unit for monitoring type SRL 6 to ensure automatic intermittent purging of the external chamber for the level electrode installed outside the boiler.

Supply in accordance with our general terms of business.

**Flowserve GESTRA U.S.**

2341 Ampere Drive  
Louisville, KY 40299  
Tel.: 001502 / 2672205, 001502 / 2672206  
Fax: 001502 / 2665397  
Email: dgoodwin@flowserve.com



**GESTRA**

## GESTRA Steam Systems

Product Range B1

### Switching Controller NRS 1-9 Combined Water Level Controller and Self-Monitoring Low Water-Level Limiter with Periodic Self-Checking

NRS 1-9

#### Purpose and Application

This combined switching controller is for on-off feedwater control, high-level alarm, and self-monitoring low water-level limiter with periodic self-checking feature to be used in conjunction with the combination electrode NRG 16-36.

The equipment meets the German regulations for use in steam-boiler plants operating without constant supervision (TRD 604).

#### Design

Plug-in unit in plastic case for installation in control cabinets. The terminals in the case are accessible after loosening two screws and unplugging the unit from its base.

The plug-in unit may be snapped onto a 35 mm supporting rail or screwed into position on a mounting panel.

Field enclosures for several plug-in units are available on request.

#### Operation

The low water-level limiter part of the switching controller is a two channel circuit provided with an automatic periodic self-checking logic unit, in accordance with DIN 57116/VDE 0116 (regulations on protection circuits for firing equipment of furnaces). The two channels are designed to monitor the operation of each other. If one channel fails, an alarm signal is initiated and switches the output contacts to shut off the heat supply to the boiler. The periodic self-checking logic unit checks the integrity of the cable between the electrode and the switching controller, and the two channel circuits for malfunction. This is done automatically every 40 seconds by the triggering of a test alarm pulse through the circuit. Unless it finds a fault, this internal test does not interfere with the output contacts of the controller and therefore the boiler operation is not interrupted. In addition, there is a secondary checking device to monitor the operation of the periodic self-checking logic unit. If no test pulse alarm is triggered, the secondary checking device will initiate an alarm signal and switches the output contacts to shut off the heat supply to the boiler.

A manual test push button is also provided. When the push button "Test I" is pressed, it simulates a fault in the electrode. There is also a test switch "Test II/Inspection" for checking the function of the self-checking circuitry.

The output contact relays of the switching controller are of the normally close type and will therefore signal alarm condition in the event of a mains failure.

The combined switching controller can signal the following four operating conditions:

- Normal operation (feedwater control)
- Alarm (high water level)
- Alarm (low water level)
- Alarm (fault in switching controller or level electrode)

A green LED indicates mains supply ON. Low water-level alarm or malfunction of the low water-level limiter part is indicated by two red LEDs. The failure of one channel (loss of redundancy) is signalled by the lighting-up of one red LED. Another green LED indicates feedwater pump running. High water level alarm is signalled by another red LED.

The combination of electrode NRG 16-36 and switching controller NRS 1-9 provides fail safe protection against a first fault, i.e. the system will still continue to provide the safety function even after the occurrence of a first fault.

#### Technical Data

**Type-approval No.**  
TÜV-WR/WB-94-370

**Input**  
Eight terminals for the connection of one combination electrode NRG 16-36, PN 40

**Output**  
**Low water-level limiter part**  
Two volt-free relay contacts

**Level controller part**  
One volt-free working contact for feedwater control on/off.  
One volt-free relay contact for "high-level alarm".  
Contact material silver, hard-gold plated.  
Max. contact rating with switching voltages of 24 V, 115 V and 240 V a.c.: 4 A resistive, 0.75 A inductive,  $\cos \varphi 0.5$ .  
Max. contact rating with a switching voltage of 24 V d.c.: 4 A.

**Delay of response**  
Low water-level limiter part: set at our factory to 1 or 3 s (up to 25 s possible).  
High water-level alarm and controller parts: set at our factory to 2 s.

**Sensitivity**  
Range 1:  $10 \mu\text{S/cm}$  at  $25^\circ\text{C}$   
Range 2:  $0.5 \mu\text{S/cm}$  at  $25^\circ\text{C}$   
Selection between the two ranges by code switch.

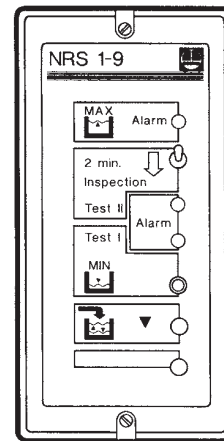
**Indicators and adjustors**  
One green LED "Mains supply on"  
Two red LEDs "Low water-level alarm"  
One button "Test I"  
One test switch "Test II/Inspection"  
One green LED "Feedwater control on"  
One red LED "High water-level alarm"  
One four-pole code switch

**Mains supply**  
220/240 V, 50/60 Hz  
(please state voltage when ordering)  
Special voltage: 115 V,  $\pm 10\%$ , 50/60 Hz or 24 V  $\pm 10\%$ , 50/60 Hz; 24 V d.c. supply also possible with the inverter type URN-1.

**Protection**  
IP 20 in acc. with DIN 40050

**Permissible ambient temperature**  
0 to  $55^\circ\text{C}$

**Case materials**  
Base: Noryl SE 1-GFN2 UL 94 VO, black  
Cover: R-ABS UL 94 VO, stone grey



Level switching controller NRS 1-9b

**Switching Controller NRS 1-9  
Combined Water Level Controller and  
Self-Monitoring  
Low Water-Level Limiter with Periodic  
Self-Checking**

**Important Notes**

Cable required for wiring to the electrode: Two four-core overall screened cables, minimum conductor size 0.5 mm<sup>2</sup>.

Max. cable length 100 m with water conductivity from 10 μS/cm.

Max. cable length 30 m with water conductivity from 0.5 μS/cm.

Max. cable length 15 m with water conductivity from 0.5 μS/cm when used in conjunction with inverter URN 1b (24 V d.c.).

When mounting the electrode into steam or pressurized hot-water boilers the relevant regulations must be considered.

The burner-protection circuit must be fused with 2.5 A (anti-surge fuse).

The switching controller does not have its own lock-out circuit. Lock-out and manual reset facilities are to be provided externally in the burner panel safety chain circuit.

**Order and Enquiry Specifications**

GESTRA level switching controller for on-off feedwater control, high water-level alarm and self-monitoring low water-level limiter with periodic self-checking:

Level switching controller type NRS 1-9b in a plastic case for installation in control cabinets.

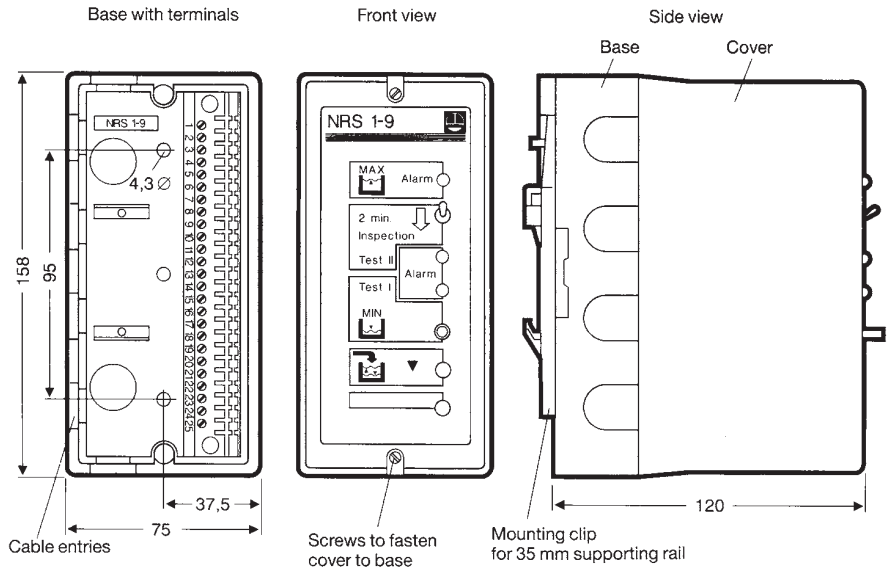
Delay of response (low water-level limiter) .....s

Mains supply .....V.....Hz

**Associated Equipment**

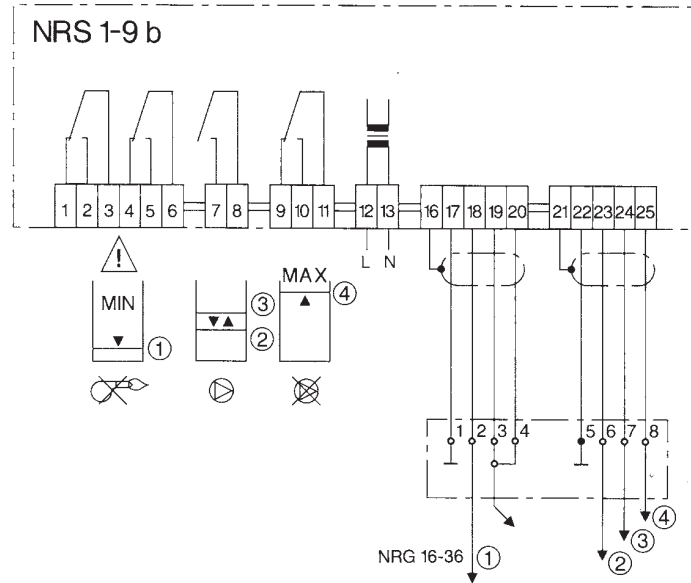
Self-monitoring combination electrode type NRG 16-36

**Dimensions**



Dimensions of switching controller type NRS 1-9b

**Wiring Diagram**



Wiring diagram for switching controller type NRS 1-9b

Supply in accordance with our general terms of business.

**Flowserve GESTRA U.S.**

2341 Ampere Drive  
Louisville, KY 40299  
Tel.: 001502 / 2672205, 001502 / 2672206  
Fax: 001502 / 2665397  
Email: dgoodwin@flowserve.com



GESTRA

## GESTRA Steam Systems

High-Level Alarm  
With CAN Bus, CANopen Protocol  
**NRG 16-41, NRG 17-41, NRG 19-41**

### System Description

The level electrode operation is based on the conductive measuring principle. The NRG 1...-41 is designed for signalling the max. liquid level in electrically conductive liquids.

- One liquid level with **one** switchpoint

The NRG 1...-41 is to be used in conjunction with the switching controller NRS 1-41 and further system components. The NRG 1...-41 in conjunction with its associated control equipment constitutes a water level limiter with periodic self-testing routine (SMART function) in accordance with TRD 604, sheet 1 and 2 and EN regulations. The level data are transferred from the electrode NRG 1...-41 to the control unit via a CAN bus using the CANopen protocol.

### Function

The conductivity of the liquid is used to signal the liquid level. Some liquids are conductive, which means that they allow an electric current to flow through them. For the safe functioning of this device a minimum conductivity of the liquid to be measured is required.

The conductivity measurement method can detect two conditions: electrode rod submerged or exposed, meaning switchpoint reached (or exceeded) or not yet reached. Before installation, the length of the electrode rod must be cut to the required switching level, e. g. for "Pump OFF" or "Control valve CLOSED" or, in case of economiser and air heaters that are installed close to the steam-generating unit and exposed to a risk, "Firing/Burner OFF".

An additional electrode fully integrated in the system automatically monitors the electrical resistance path between earth and measuring electrode. As soon as the actual value falls below the admissible resistance value the protection circuit is interrupted and cuts off the pump or heat supply to the boiler.

At regular intervals the level electrode NRG 1...-41 sends a data telegram to the switching controller NRS 1-41. The data are transferred via a CAN bus to DIN ISO 11898 using the CANopen protocol.

### Design

NRG 1...-41: Screwed 3/4" BSP, EN ISO 228-1

### Technical Data

#### Type Approval

TÜV - SWB / SHWS - 02-403  
EG BAF-MUC 02 02 103881 002

#### Service pressure

NRG 16-41: 32 barg at 238 °C  
NRG 17-41: 60 barg at 275 °C  
NRG 19-41: 100 barg at 311 °C

#### Connection

Screwed 3/4" BSP, EN ISO 228-1

#### Materials

Terminal box: Die cast aluminium 3.2161 (G AISi8Cu3)  
Stem: S. S. 1.4571 (X6CrNiMoTi17-12-2)  
Measuring electrode: S. S. 1.4401 (X5CrNiMo17-12-2)  
Electrode insulation: PEEK

#### Lengths supplied

500 mm  
1000 mm  
1500 mm

#### Sensitivity of response

> 0.5 µS/cm at 25 °C.

#### Supply voltage

18–36 V DC (coming from NRS 1-41)

#### Current consumption

35 mA

#### Fuse

Electronic thermal fuse  $T_{max} = 85 °C$

#### Hysteresis

-2 K

#### Electrode voltage

2 V<sub>SS</sub>

#### Data exchange

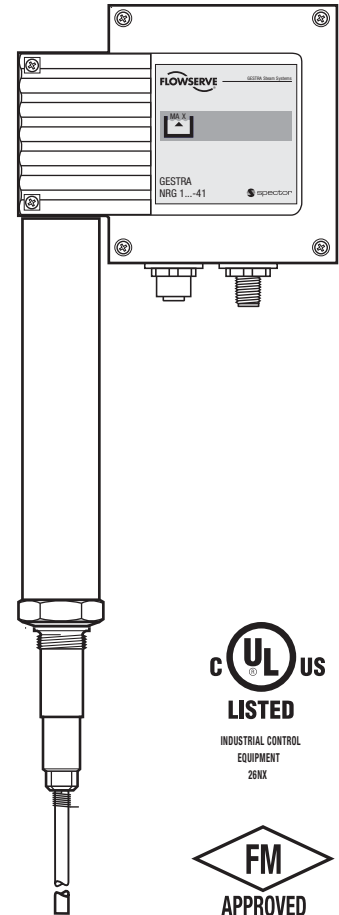
CAN bus to DIN ISO 11898, CANopen Protocol

## Product Range B

**NRG 16-41**

**NRG 17-41**

**NRG 19-41**



P.T.O.

### Important Note

Note that screened multi-core twisted-pair control cable is required for the BUS line, e. g. UNITRONIC® BUS CAN 2 x 2 x ... mm<sup>2</sup> or RE-2YCYV-fi 2 x 2 x ... mm<sup>2</sup>.

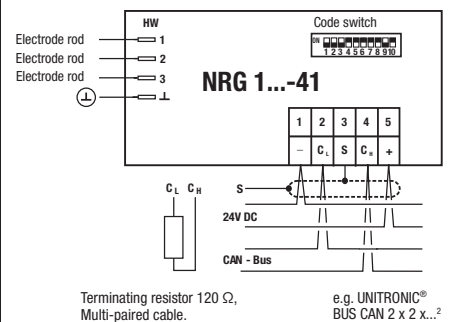
Prefabricated control cables (with connector and coupler) of various lengths for connecting the equipment are available as accessories. The baud rate (data transfer rate) dictates the cable length between the bus nodes and the total power consumption of the sensor dictates the conductor size.

S 8	S 9	S 10	Baud rate	Cable length	Number of pairs and conductor size [mm <sup>2</sup> ]
OFF	ON	OFF	250 kBit/s	125 m	2 x 2 x 0.34
<b>Factory setting</b>					
ON	ON	OFF	125 kBit/s	250 m	2 x 2 x 0.5
OFF	OFF	ON	100 kBit/s	335 m	2 x 2 x 0.75
ON	OFF	ON	50 kBit/s	500 m	on request, dependent on bus configuration
OFF	ON	ON	20 kBit/s	1000 m	
ON	ON	ON	10 kBit/s	1000 m	
ON	ON	ON	10 kBit/s	1000 m	

The baud rate is set via a code switch. Reduce baud if cable is longer than specified in the table. Make sure that all bus nodes have the same settings. To protect the switching contacts fuse circuit with 2.5 A (anti-surge fuse) or according to TRD regulations (1.0 A for 72 hrs operation).

**Note: If the cable is longer than 125 m (max. 1000 m!) the baud rate must be changed.**

### Wiring Diagram



Terminating resistor 120 Ω,  
Multi-paired cable. e.g. UNITRONIC®  
BUS CAN 2 x 2 x ...<sup>2</sup>

# High-Level Alarm With CAN Bus, CANopen Protocol NRG 16-41, NRG 17-41, NRG 19-41

## Technical Data – continued –

### Indicators and adjustors

One 10-pole code switch for node ID and baud rate settings  
Two LEDs "PROGRAM RUNNING"  
Two LEDs "CAN BUS COMMUNICATION"

### Electric connection

M 12 sensor connector, 5 poles, A-coded,  
M 12 sensor jack, 5 poles, A-coded

### Protection

IP 65 to DIN EN 60529

### Max. admissible ambient temperature

70 °C

### Weight

Approx. 2.5 kg

## Order and Enquiry Specification

GESTRA Level electrode NRG 1...-41

## Associated Controller

■ Switching controller NRS 1-41

## Ancillary Unit

■ Operating terminal & visual display unit URB 1, URB 2

## Key

- A** Flange PN 40, DN 50, DIN 2527  
Flange PN 40, DN 100, DIN 2527
- B** For the approval of the boiler standpipe with connecting flange the relevant regulations must be considered.
- C** Vent hole
- D** Electrode rod  $d = 8$  mm
- E** Protection tube  $\geq$  DN 100
- F** High water level (HW)
- G** Reducer K-88.9 x 3.2 - 42.4 x 2.6 W!
- H** Electrode distance
- I** Lengths of electrode tips  
500 mm  
1000 mm  
1500 mm
- J** Low water level (LW)

## ATEX (Atmosphère Explosible)

According to the European Directive 94/9/EC the equipment must **not** be used in explosion-risk areas.

Supply in accordance with our general terms of business.

## Dimensions

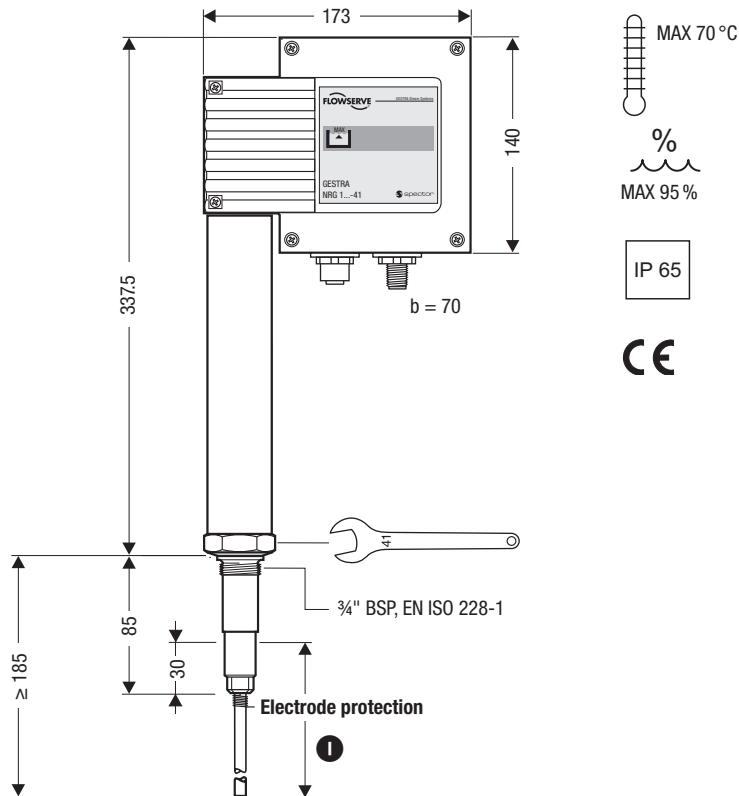


Fig. 1 NRG 16-41, NRG 17-41

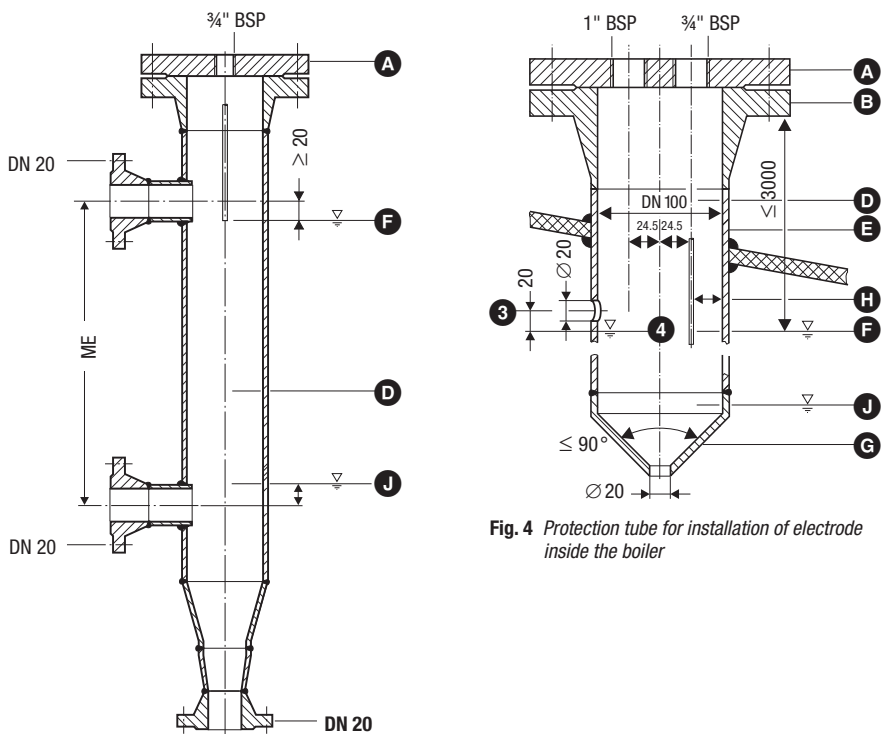


Fig. 2 External measuring pot

Fig. 4 Protection tube for installation of electrode inside the boiler

# Flowserve GESTRA U.S.

2341 Ampere Drive  
Louisville, KY 40299  
Tel.: 001502 / 2672205, 001502 / 2672206  
Fax: 001502 / 2665397  
Email: dgoodwin@flowserve.com



GESTRA

## GESTRA Steam Systems

Level Limiting  
With CAN Bus, CANopen Protocol  
**NRG 16-40, NRG 17-40, NRG 19-40**

Product Range B1

**NRG 16-40**  
**NRG 17-40**  
**NRG 19-40**

### Description

The level electrodes NRG 1...-40 work according to the conductivity measurement principle and detect the min. level in electrically conductive liquids:

- One level alarm with **one** switchpoint

Use level electrode NRG 1...-40 in combination with level switch NRS 1-40 or NRS 1-40.1 and/or other system components. The NRG 1...-40 in conjunction with its associated control equipment constitutes a water level limiter with periodic self-testing routine (SMART function) in accordance with TRD 604, sheet 1 and 2 and EN regulations. The level data are transferred from the electrode NRG 1...-40 to the control unit via a CAN bus using the CANopen protocol.

### Function

The electrode operation is based on the conductive measuring principle using the electrical conductivity for signalling liquid levels. Some liquids are conductive, which means that they allow an electric current to flow through them. For the safe functioning of this device a minimum conductivity of the liquid to be monitored is required.

The conductivity measurement method can detect two conditions: electrode rod submerged or exposed, meaning switchpoint reached (or exceeded) or not yet reached. Before installation, the electrode rod must be cut to length to give the required low-level alarm and effect the consequent cut-out of the burner circuit.

The system incorporates an additional electrode that provides automatic monitoring of the electrical resistance path between the measuring electrode and the earth. When the measured value falls below the admissible resistance value the burner shutdown is endorsed by interruption of the burner protection circuit.

At regular intervals, the level electrode NRG 1...-40 sends a data telegram to the controller NRS 1-40. The data transfer is effected by means of a CAN bus according to DIN ISO 11898 adopting the CANopen protocol. **One** controller type NRS 1-40 can be used for **two** level electrodes NRG 1...-40 (**low-level limiter arrangement**).

### Design

Screwed 3/4" BSP to EN ISO 228-1

### Technical Data

#### Type approval no.

TÜV - SWB / SHWS - 02-403  
EG BAF-MUC 02 02 103881 002

#### Service pressure

NRG 16-40, PN 40, 32 bar g (464 psig) at 238 °C  
NRG 17-40, PN 63, 60 bar g (870 psig) at 275 °C  
NRG 19-40, PN 160, 100 bar g (1450 psig) at 311 °C

#### Connection

Screwed BSP 3/4", EN ISO 228-1

#### Materials

Terminal box: 3.2161 G AISI8Cu3  
Stem: 1.4571, X6CrNiMoTi17-12-2  
Measuring electrode: 1.4401, X5CrNiMo17-12-2  
Electrode insulation: Gylon®

#### Lengths supplied

500 mm, 1000 mm, 1500 mm,  
2000 mm, 2500 mm, 3000 mm

#### Sensitivity

> 0.5 µS/cm at 25°C

#### Supply voltage

18–36 V DC (coming from NRS 1-40 / NRS 1-40.1)

#### Current consumption

35 mA

#### Fuse

Thermal fuse  $T_{max} = 85 °C$ , hysteresis 2 K

#### Hysteresis

-2 K

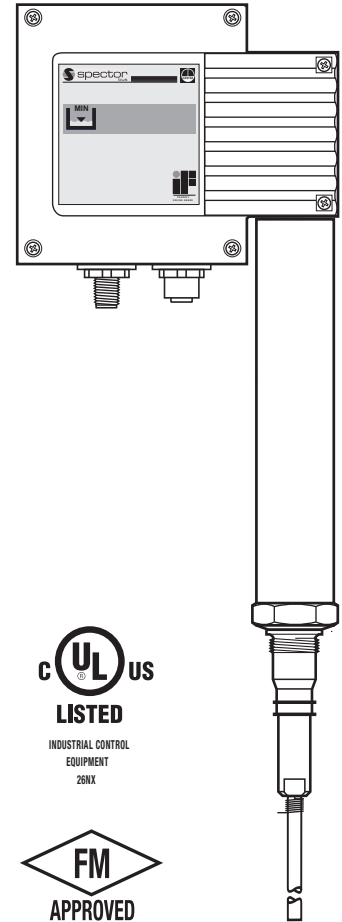
#### Electrode voltage

2 V<sub>ss</sub>

#### Data exchange

CAN bus to DIN ISO 11898, CANopen protocol

– continued – P.T.O.



### Important Note

Note that screened multi-core twisted-pair control cable is required for the BUS line, e. g. UNITRONIC® BUS CAN 2 x 2 x ... mm<sup>2</sup> or RE-2YCYV-fl 2 x 2 x ... mm<sup>2</sup>.

Prefabricated control cables (with connector and coupler) of various lengths for connecting the equipment are available as accessories. The baud rate (data transfer rate) dictates the cable length between the bus nodes and the total power consumption of the sensor dictates the conductor size.

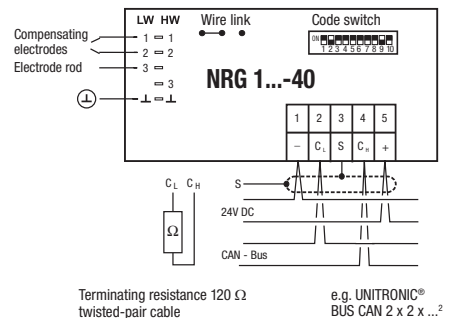
S 8	S 9	S 10	Baud rate	Cable length	Number of pairs and conductor size [mm <sup>2</sup> ]
OFF	ON	OFF	250 kBit/s	125 m	2 x 2 x 0.34
<b>Factory setting</b>					
ON	ON	OFF	125 kBit/s	250 m	2 x 2 x 0.5
OFF	OFF	ON	100 kBit/s	335 m	2 x 2 x 0.75
ON	OFF	ON	50 kBit/s	500 m	on request, dependent on bus configuration
OFF	ON	ON	20 kBit/s	1000 m	
ON	ON	ON	10 kBit/s	1000 m	

The baud rate is set via a code switch. Reduce baud rate if cable is longer than specified in the table. Make sure that all bus nodes have the same settings.

To protect the switching contacts fuse circuit with 2.5 A (anti-surge fuse) or according to TRD regulations (1.0 A for 72 hrs operation).

**Note: If the cable is longer than 125 m (max. 1000 m!) the baud rate must be changed.**

### Wiring Diagram



## Level Limiting With CAN Bus, CANopen Protocol NRG 16-40, NRG 17-40, NRG 19-40

### Technical Data continued

#### Indicators and adjustors

One 10-pole code switch for node ID and baud rate settings

One wire link (for switching between electrode 1 and electrode 2)

#### Electric connection

M 12 sensor connector, 5 poles, A-coded,  
M 12 sensor jack, 5 poles, A-coded

#### Protection

IP 65 to DIN EN 60529

#### Max. admissible ambient temperature

70 °C

#### Weight

Approx. 2.5 kg

### Order and Enquiry Specification

GESTRA Level Electrode Type NRG 1...-40

### Associated Controller

- Level switch type NRS 1-40
- Level switch type NRS 1-40.1

### Ancillary Unit

- Visual display unit type URB 1, URB 2

### Key

- 1 Flange PN 40, DN 50, DIN 2527  
Flange PN 40, DN 100, DIN 2527
- 2 For the approval of the boiler standpipe with connecting flange the relevant regulations must be considered.
- 3 Vent hole
- 4 High water (HW)
- 5 Electrode rod  $d = 8$  mm
- 6 Protection tube DN 80
- 8 Electrode distance  $\geq 14$  mm
- 9 Low water (LW)
- 10 Reducer DIN 2616-2, K-88.9 x 3.2 - 42.4 x 2.6 W
- 12 Solenoid valve

### PED (Pressure Equipment Directive)

The equipment complies with the requirements of the Pressure Equipment Directive 97/23/EC. Applicable in fluids of group 1 and 2. With CE marking, except for equipment according to section 3.3 of the PED.

### ATEX (Atmosphère Explosible)

According to the European Directive 94/9/EC the equipment must **not** be used in explosion-risk areas.

Supply in accordance with our general terms of business.

### Dimensions

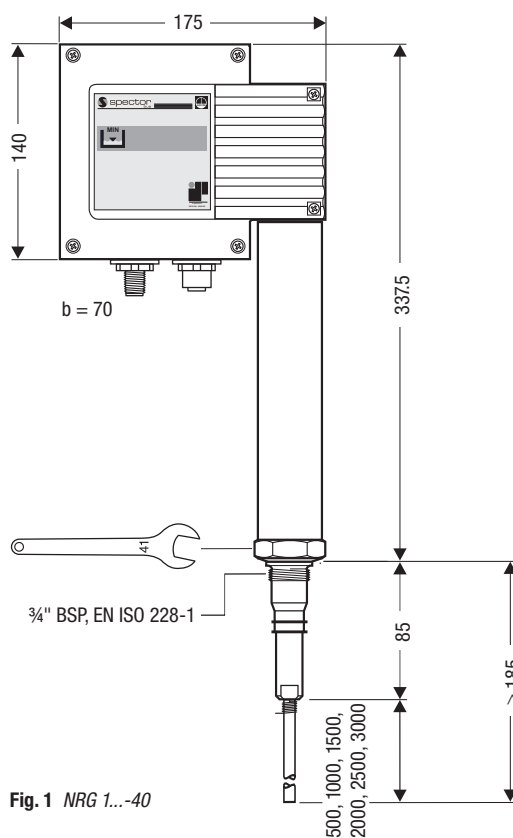


Fig. 1 NRG 1...-40

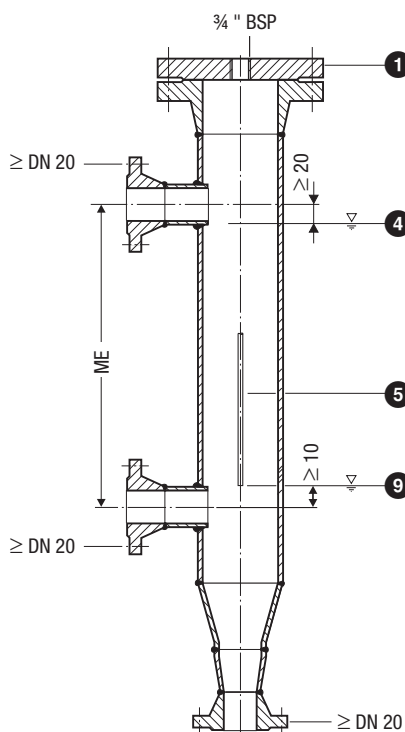


Fig. 2 External measuring pot

MAX 70 °C

%  
MAX 95 %

IP 65

CE

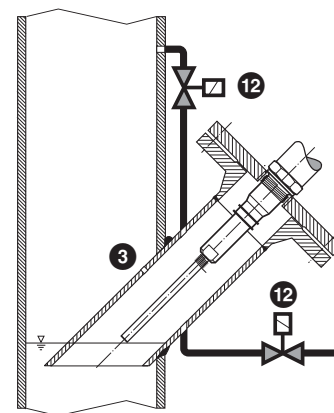


Fig. 3 Example of a real-function check in a rising feed main of a pressurized hot-water boiler

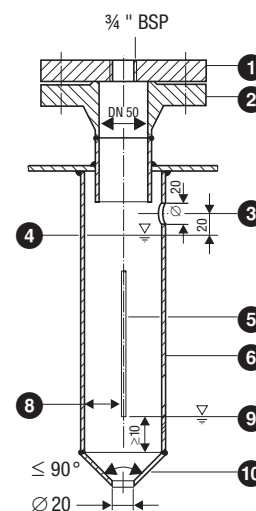


Fig. 4 Protection tube for installation of electrode inside the boiler

## Flowserve GESTRA U.S.

2341 Ampere Drive  
Louisville, KY 40299  
Tel.: 001502 / 2672205, 001502 / 2672206  
Fax: 001502 / 2665397  
Email: dgoodwin@flowserve.com

**FLOWSERVE**

GESTRA



## GESTRA Steam Systems

Product Range B1

### Capacitance Level Probe Type NRG 211

### NRG 211

#### Purpose and Application

In combination with GESTRA level switch type NRS 2-4 for indication of high water level and level switch type NRS 2-5 for indication of low water level, at very high pressures and temperatures (up to PN 320, 550 °C).

Application in draining systems of conventional power stations and high pressure steam boilers.

#### Design

The probe works without any moving parts. The probe rod, which is insulated by a ceramic tube, is inserted through a hole in the probe flange such that pressure-tight sealing is ensured. The ceramic tube is closed at the lower end and covered by a protection tube to obtain constant measuring conditions and protect the ceramic tube.

The electronic control unit is housed in the terminal box. The wiring is effected via a 6 pole connector with crimp connection.

#### Operation

The principle of capacitance measurement is applied to determine level. The probe rod and the protection tube from a capacitor, with air or the particular liquid being the dielectric. In electrically conductive liquids the probe insulation serves as the dielectric. As the level rises or falls, the capacitance of this assembly changes, is converted in the integral measuring transducer into a signal, and is then fed to the associated electronic control unit.

#### Technical Data

##### Max. service pressure

Probe flange / welding standpipe  
15Mo3 (1.5415)  
320 bar (4642 psig) at 120°C  
200 bar (2901 psig) at 450°C

Probe flange/welding standpipe  
10CrMo910 (1.7380)  
320 bar (4642 psig) at 120°C  
200 bar (2901 psig) at 500°C

Probe flange/welding standpipe  
X20CrMoV121 (1.4922)  
320 bar (4642 psig) at 120°C  
230 bar (3336 psig) at 550°C

\*) The indicated ratings are approximate values and for guidance when selecting materials. For an exact specification consider pressure/temperature ratings of the particular plant.

##### Connection

Probe flange PN 320 with welding standpipe for pipes DN ≤ 100 with tee piece or for pipes DN > 100 with lateral penetration.

##### Dimensions

See overleaf for drawings

##### Materials

Probe flange/welding standpipe refer to "Max. service pressure"

Joint ring X 6 CrNiTi18-10 (1.4541)/silver, with serrated faces and silver coating on both ends.

Terminal box: aluminium, enamel finish

#### Technical Data – continued –

**Max. ambient temperature at terminal box**  
70 °C

##### Wiring

via 6 pole connector with crimp connection or cable gland Pg 11 to terminals.

**Max. admissible pH value**  
≤ 10

##### Probe voltage

12 V DC 30 mA

##### Protection

IP 54

##### Weight

Probe approx. 5.6 kg

Welding standpipe approx. 4.5 kg

#### Important Notes

Required cable for wiring: Screened cable, 3 x 0.5 mm<sup>2</sup>, max. cable length 500 m.

When welding the standpipe into position it should be inclined downwards by at least 5° to ensure that the standpipe can completely empty if the level falls.

We recommend full-penetration butt welding (e.g. type 22 to DIN 2559) for the connection to pipes (tee pieces) DN ≤ 100.

With larger pipes the welding standpipe can be introduced through a lateral penetration and then be welded.

In case of plants which are subject to surveillance the corresponding regulations must be observed.

For connections provided on site see "Installation Instructions" and "Technical Data".

#### Order and Enquiry Specifications

Capacitance level probe type NRG 211

Probe flange with welding standpipe for pipes (DN)

Material .....

Max. service pressure .....

Max. service temperature .....

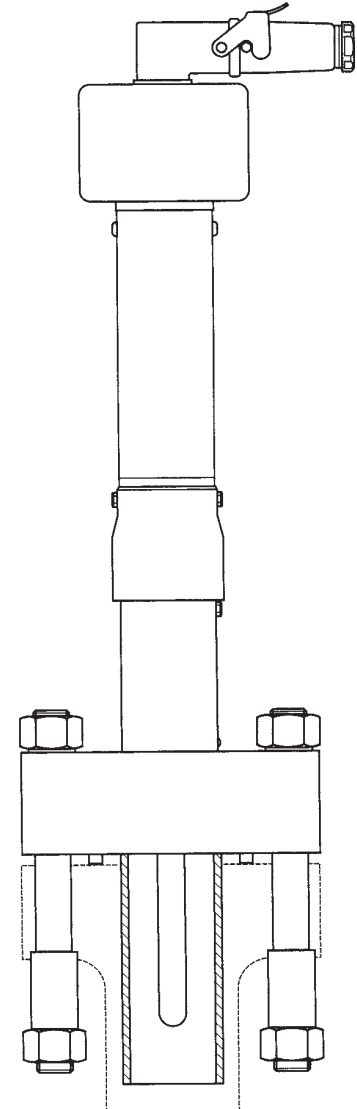
Fluid .....

#### When ordering please state:

The following test certificates can be issued on request, at extra cost: In accordance with DIN EN 10204-2.1, -2.2 and -3.1B, 3.1A2.

All inspection requirements have to be stated with the order. After supply of the equipment certificates can no longer be established. Charges and extent of the above mentioned certificates as well as the different tests confirmed therein are listed in our price list "Test and Inspection Charges for Standard Equipment".

For other tests and inspections then those listed above, please consult us.



NRG 211

# Capacitance Level Probe Type NRG 211

## Installation of welding standpipe

Weld the standpipe according to the **Fig. 1** or **Fig. 2** to the pipe. Take note of the marking "TOP". During the welding process and post weld heat treatment of the standpipe the temperature of the flange seating surface must not exceed 350 °C.

## Installation of probe

Clean flange seating surfaces. Insert joint ring into the groove of the welding standpipe and put the probe onto it such that the cable outlet at the terminal box shows to the bottom. The joint ring has serrated faces and silver coatings on both ends. Do not remove the rings (see drawing).

Tighten expansion bolts in diagonally opposite pairs with a torque of **70 Nm**, then repeat procedure with **130 Nm**.

**NOTE:** Do not lag the covering and terminal box (danger of overheating).

## Wiring

When connector is provided connect the probe according to wiring diagram. Use cable 3 x 0.5 mm<sup>2</sup> for wiring. Connect screen only to the corresponding terminal of the electronic control unit but not to the probe. Standard voltage: 24 V DC

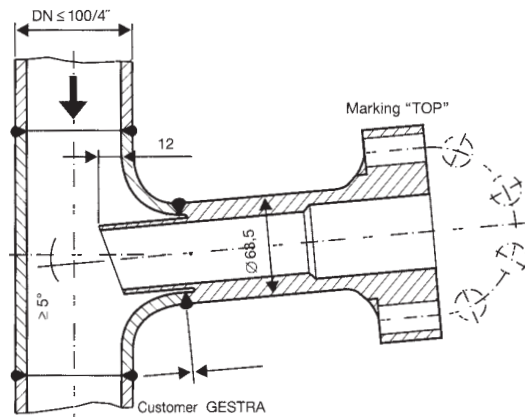
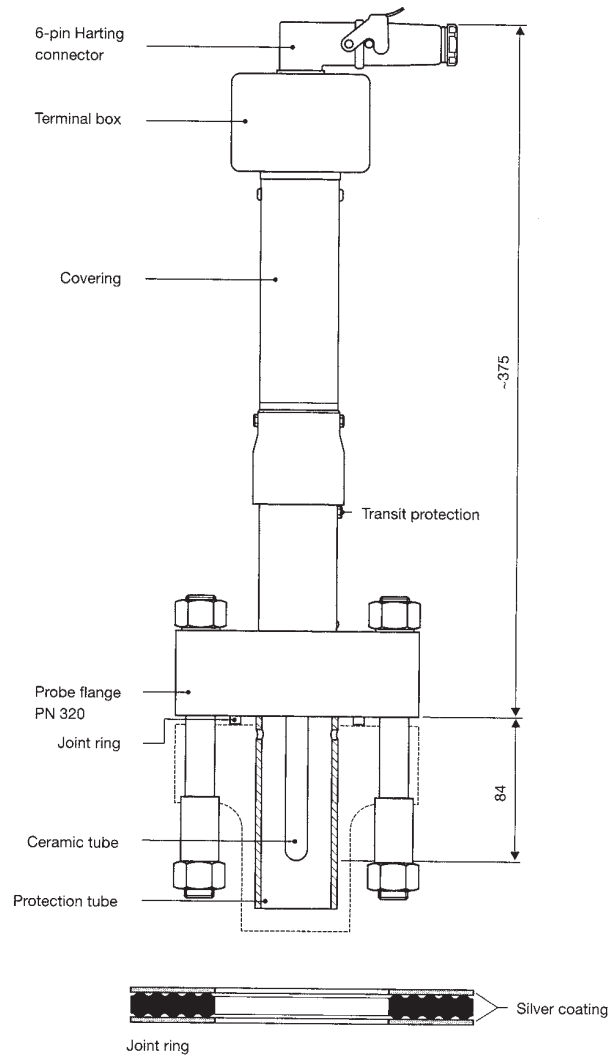
## Associated level switch

NRS 2-4 and NRS 2-5 with one relay and one optocoupler output each for "Malfunction" and "Alarm".

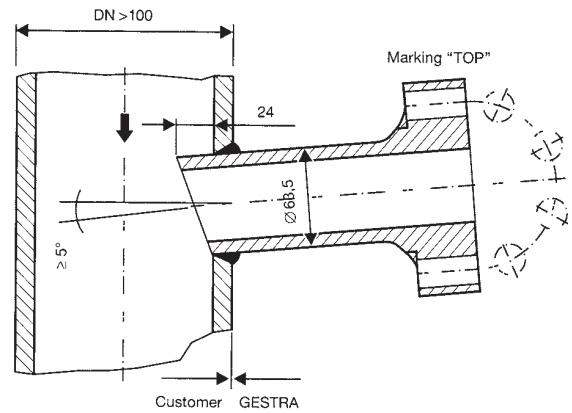
## Additional equipment

- Cycling timer type PRS 9 with max.-min. limit switch for the control of a drain valve.
- Power supply unit type URN 2 at 115/230 V, 50 Hz, voltage supply
- Casing for accessories

## Dimensions



**Fig. 1** Welding of standpipe to pipes (tee pieces) DN ≤ 100



**Fig. 2** Welding of standpipe to pipes (tee pieces) DN > 100

Supply in accordance with our general terms of business.

# Flowserve GESTRA U.S.

2341 Ampere Drive  
Louisville, KY 40299  
Tel.: 001502 / 2672205, 001502 / 2672206  
Fax: 001502 / 2665397  
Email: dgoodwin@flowserve.com



GESTRA

## GESTRA Steam Systems

Product Range B2

### Level Switch Type NRS 2-4

### NRS 2-4

#### System Description

The level switch NRS 2-4 is an analogue electronic amplifier for the capacitance electrode type NRG 211.

In combination with this level electrode it can detect high water level. In addition, the level switch evaluates possible malfunction signals coming from the electrode and monitors the electrode supply cable and can therefore be used as part of a controlled draining system in power stations.

#### Function

The measuring voltage delivered by the electrode is decoded as a function of its magnitude and indicated by LEDs when there is a malfunction in the electrode supply cable or in the electrode and when the electrode is exposed or submerged (high level).

In the case of a malfunction the output relay MALFUNCTION is energized. When the electrode is submerged (high level) the output relay ALARM is energized.

Optocouplers are connected in parallel and assigned to the output relays. They will be energized in the event of a malfunction or an alarm.

#### Design

##### NRS 2-4 c

19" slide-in unit with guide rails and 32 pole screw-type connector for installation in 19" magazines to DIN 41494 part 5.

##### NRS 2-4 d

Spare 19" slide-in unit.

#### Important Note

Use screened four-core cable, e.g. 4 x 0.5 mm<sup>2</sup>. Max. cable length 500 m.

#### Technical Data

##### Supply voltage

24 V DC

##### Power consumption

2 VA

##### Output – Measuring circuit

12 V DC (supply voltage going to level electrode) 30 mA

##### Input – Measuring circuit

1 – 10 V DC (measuring voltage coming from level electrode)

##### Output – Control circuit

2 volt-free relay contacts

Max. contact rating with switching voltages of 24/115 / 230 V AC: 4 A resistive, 0.75 A inductive at cos φ 0.5.

Max. contact rating with switching voltage

24 V DC: 4 A.

Service life of relay: 30 x 10<sup>6</sup> switching cycles

2 optocouplers (npn), short-circuit protected due to inherent current limiting characteristics.

Max. ratings: 70 V, 10 mA.

##### Indicators and adjusters

1 green LED OPERATION, 1 red LED HIGH LEVEL,

1 yellow LED DEFECTIVE ELECTRODE, 1 yellow LED

MALFUNCTION IN CABLE.

##### Protection

IP 10 to DIN 40050

##### Max. admissible ambient temperature

0 °C to + 70 °C

##### Case

19" slide-in unit with front panel to DIN 41494 part 5 and rear 32 way Euro card connector to DIN 41612 for installation into 19" magazine.

Front panel: aluminium.

##### Weight

Approx. 0.6 kg

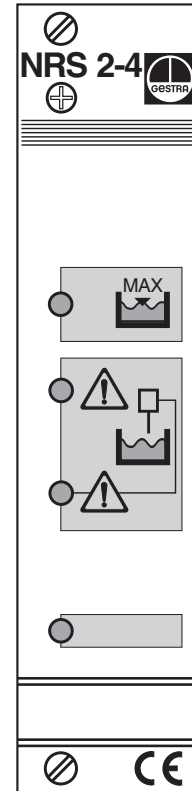
#### Order and Enquiry Specification

GESTRA Level switch NRS 2-4

- 19" slide-in unit with guide rails  
NRS 2-4 c
- Spare 19" slide-in unit  
NRS 2-4 d

#### Ancillary Unit

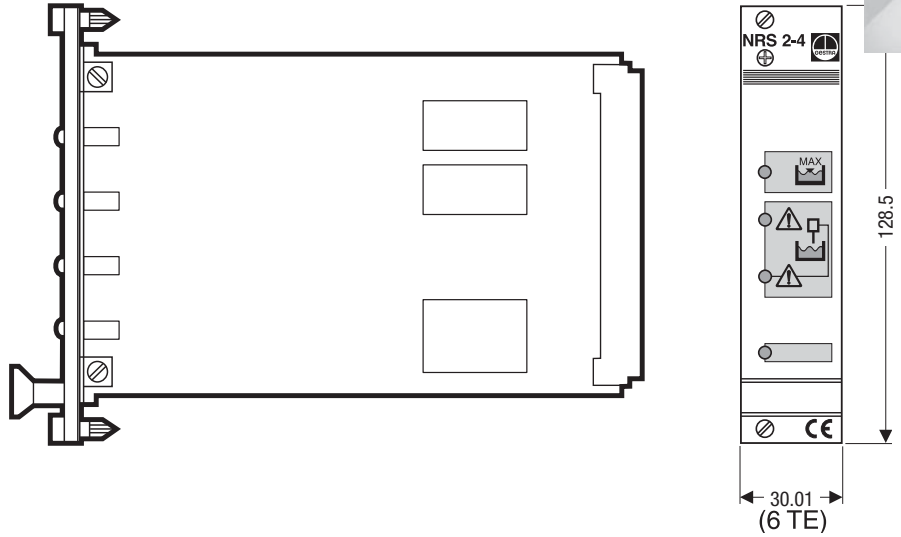
- Level electrode NRG 211
- Power supply unit URN 2



Level switch NRS 2-4

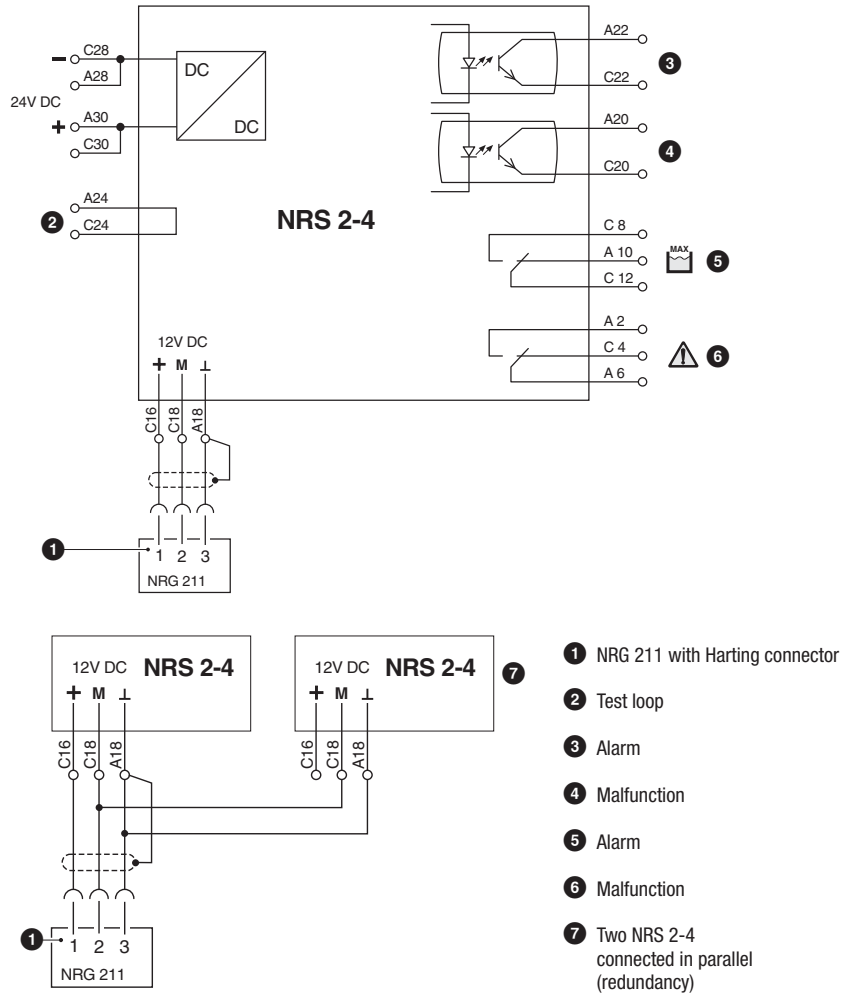
Level Switch Type  
**NRS 2-4**

**Dimensions**



**Wiring Diagram**

Design "c" / "d"



Supply in accordance with our general terms of business.

**Flowserve GESTRA U.S.**

2341 Ampere Drive  
 Louisville, KY 40299  
 Tel.: 001502 / 2672205, 001502 / 2672206  
 Fax: 001502 / 2665397  
 Email: dgoodwin@flowserve.com



## GESTRA Steam Systems

Product Range B2

### Level Switch Type NRS 2-5

NRS 2-5

#### System Description

The level switch NRS 2-5 is an analogue electronic amplifier for the capacitance electrode NRG 211.

In combination with this level electrode it can detect low water level. In addition, the level switch evaluates possible malfunction signals coming from the electrode and monitors the electrode supply cable and can therefore be used as part of a minimum level monitoring system / low-level alarm.

#### Function

The measuring voltage delivered by the electrode is decoded as a function of its magnitude and indicated by LEDs when there is a malfunction in the electrode supply cable or in the electrode and when the electrode is exposed or submerged.

In the case of a malfunction the output relay MALFUNCTION is de-energized. When the electrode tip is submerged (normal level) the output relay is energized to cancel the alarm output.

Optocouplers are connected in parallel and assigned to the output relays. They will be de-energized in the event of a malfunction or an alarm.

#### Design

##### NRS 2-5 c

19" slide-in unit with guide rails and 32 pole screw-type connector for installation in 19" magazines to DIN 41494 part 5.

##### NRS 2-5 d

Spare 19" slide-in unit.

#### Important Note

Use screened four-core cable, e.g. 4 x 0.5 mm<sup>2</sup>. Max. cable length 500 m.

#### Technical Data

##### Supply voltage

24 V DC

##### Power consumption

2 VA

##### Output – Measuring circuit

12 V DC (supply voltage going to level electrode)  
30 mA

##### Input – Measuring circuit

1 – 10 V DC (measuring voltage coming from level electrode)

##### Output – Control circuit

2 volt-free relay contacts.

Max. contact rating with switching voltages of 24/115/230 V AC: 4 A resistive, 0.75 A inductive at cos 0.5.

Max. contact rating with switching voltage

24 V DC: 4 A

Service life or relay: 30 x 10<sup>6</sup> switching cycles

2 Optocouplers (npn), short-circuit protected due to inherent current limiting characteristics

Max. ratings: 70 V, 10 mA

##### Indicators and adjustors

1 green LED OPERATION, 1 red LED LOW LEVEL,

1 yellow LED MALFUNCTION IN ELECTRODE,

1 yellow LED MALFUNCTION IN CABLE

##### Protection

IP 10 to DIN 40050

##### Max. admissible ambient temperature

0 °C to +70 °C

##### Case

19" slide-in unit with front panel to DIN 41494 part 5 and rear 32 way Euro card connector to DIN 41612 for installation into 19" magazine. Front panel: aluminium.

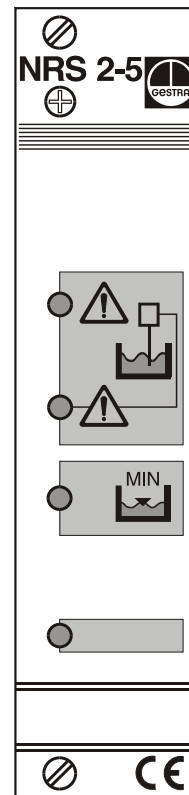
##### Weight

approx. 0.6 kg

#### Order and Enquiry Specification

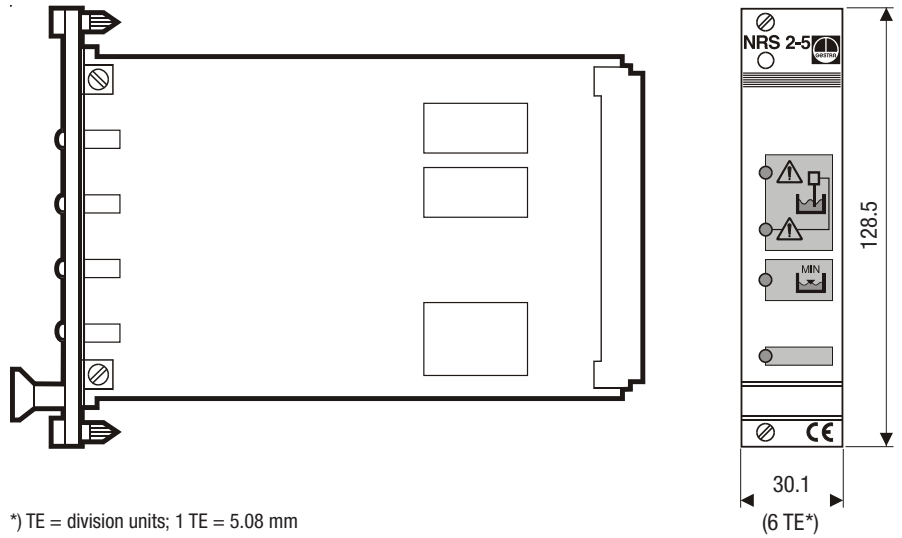
GESTRA Level switch NRS 2-5

- 19" slide-in unit with guide rails  
NRS 2-5 c
- spare 19" slide-in  
unit NRS 2-5 d



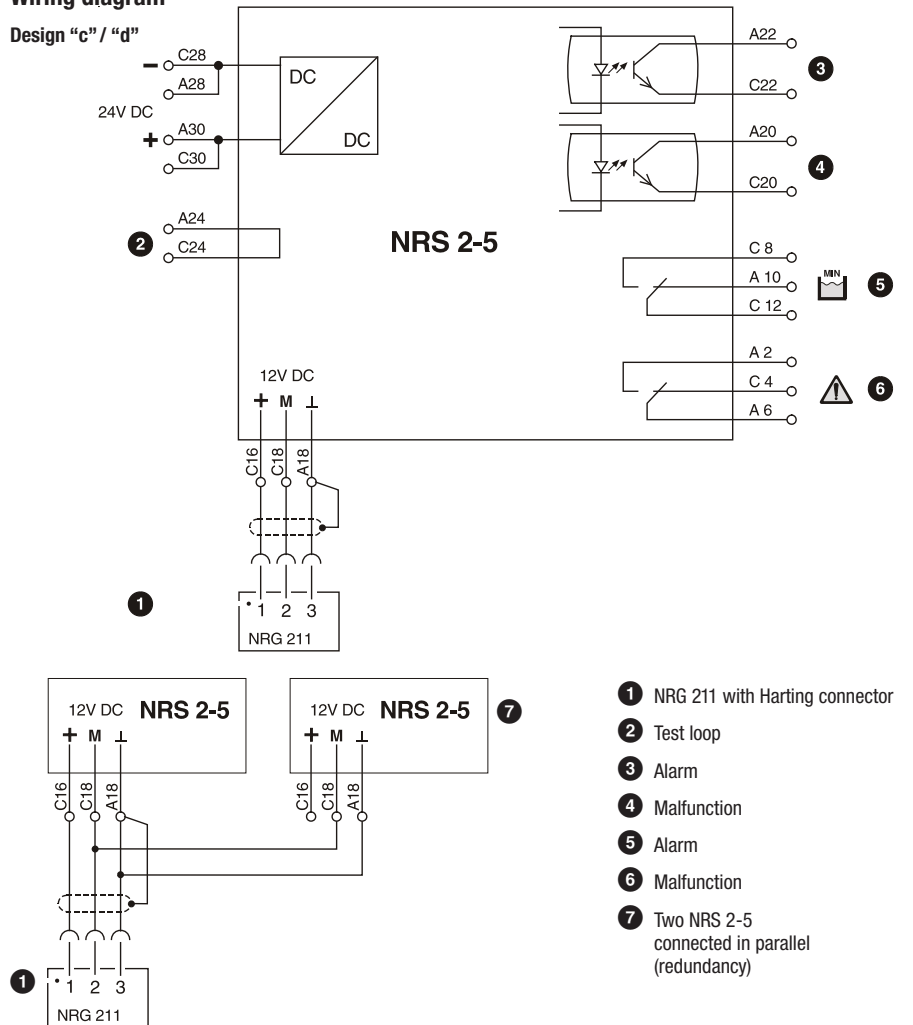
Level Switch Type  
NRS 2-5

Dimensions



Wiring diagram

Design "c" / "d"



Supply in accordance with our general terms of business.

Flowserve GESTRA U.S.

2341 Ampere Drive  
 Louisville, KY 40299  
 Tel.: 001502 / 2672205, 001502 / 2672206  
 Fax: 001502 / 2665397  
 Email: dgoodwin@flowserve.com



GESTRA

## GESTRA Steam Systems

### Low-Level Limiter / Limiting System Type NRS 1-40

## Product Range B

### NRS 1-40

#### Description

##### Low-level limiter with one level electrode

The switching controller type NRS 1-40 is a self-monitoring low-water level limiter with periodic self-checking and monitoring feature of the output relay contacts, to be used in conjunction with **one** level electrode type NRG 16-40, 17-40 or 19-40. The controller has the following function:

##### Low-water level alarm with one switchpoint

The equipment detects the min. water level (low-level limiter) and complies with the German Regulations for use in steam and hot-water plants operating without constant supervision according to TRD 401 and TRD 602.

##### Low-level limiting system with two level electrodes

When used with **two** level electrodes type NRG 16-40, 17-40 or 19-40, the controller NRS 1-40 constitutes a high-integrity low-water level limiter **system** with periodic self-checking. The controller features the following function:

##### Low-water level alarm with one switchpoint, dual-channel redundancy

Application in steam and hot-water plants operating without constant supervision according to TRD 604, sheet 1 and 2 (24/72 hrs.) and EN 12952, EN 12953.

This item of electrical equipment complies with the Technical Regulations on Protection Circuits to DIN VDE 0116 (prEN 50156).

The level data are transferred from the electrode NRG 1...-40 to the controller via CAN bus using the CANopen protocol.

#### Function

At regular intervals the level electrode NRG 1...-40 sends a data telegram to the controller NRS 1-40. The data transfer is effected by means of a CAN bus according to DIN ISO 11898. The transferred measuring data are constantly evaluated by the controller. A periodic self-checking routine tests every 3 seconds the integrity of the system and its safety functions, with a malfunction in the controller resulting in immediate boiler shut-down. When the CAN bus line and, consequently, the data trans-

mitting cycle are interrupted, the controller sends a visual signal to indicate a faulty condition and the relays are instantaneously de-energized (fail-safe position).

The controller also facilitates user-friendly performance tests and detection/evaluation of malfunctions.

To guarantee the correct and safe functioning of the low-level limiter a min. electrical conductivity of 0.5 µS/cm at 25 °C is required.

The relay de-energizing delay is normally set to 3 seconds at the factory but delays of 15 to 25 seconds are available on request.

Apart from the burner protection circuit there is also a separate Photo-MOS make contact output for remote indication.

#### Design

##### NRS 1-40 b

Enclosure of insulating material with externally accessible terminals.

Clipping onto a 35 mm standardized supporting rail (DIN EN 50022).

External dimensions: 73 x 100 x 118 mm

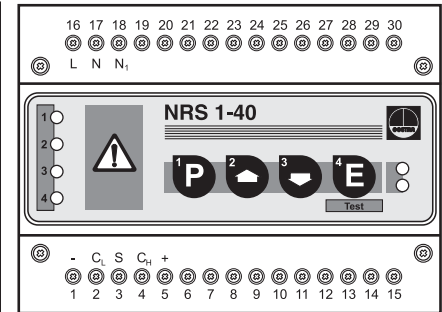
#### CAN-Bus

All controllers and associated level electrodes are interconnected by means of a CAN bus using the CANopen protocol. Every item of equipment features an electronic address (node ID). The four-core bus cable serves as power supply and data highway for high-speed data exchange.

The CAN address (node ID) for the NRS 1-40 can be set between **1** and **123**.

The low-level limiter, consisting of **one** level electrode and **one** controller, is configured at our works and ready for service. The low-level limiter can be used straight away without having to set the node ID.

For a low-level limiter **system**, consisting of **two** level electrodes and **one** controller, the **second** level electrode has to be configured. The low-level limiter system can be used after setting the respective node IDs. The baud rate set at our factory is 250 kb/s.



#### CANopen

The CANopen bus for the controller type NRS 1-40 uses the CANopen protocol. A separate Electronic Data Sheet is available detailing the configuration procedure.

#### Technical Data

##### Type approval no.

TÜV · SWB/SHWS 02-403

EG BAF-MUC 0202 103881 002

##### Input / Output

Interface for CAN bus to DIN ISO 11898 CANopen

##### Output – voltage supply for electrode(s)

18 – 36 V, short-circuit protected

##### Output – for protection circuit

Two volt-free relay contacts, locally connected in series.

Max. contact rating for switching voltages 24 V AC/DC, 115 V AC and 230 V AC: 4 A resistive/inductive.

Contact material: AgNi 0,15

##### Interference suppression

Provide contactor with external RC combination

(100 Ω / 47 nF)

##### Signal output

Photo-MOS output, instantaneous low-level alarm, timed malfunction signal, max. contact rating for switching voltages 24 V AC, 115 V AC and 230 V AC/DC: 100 mA resistive

P.T.O

#### Important Note

Note that screened multi-core twisted-pair control cable is required, e. g. UNITRONIC® BUS CAN 2 x 2 x ...<sup>2</sup> or RE-2YCYV-fl 2 x 2 x ...<sup>2</sup>.

The baud rate (data transfer rate) dictates the cable length between the bus nodes and the total power consumption of the measuring sensors dictates the conductor size.

S 8	S 9	S 10	Baud rate	Cable length	Number of pairs and conductor size [mm <sup>2</sup> ]
OFF	ON	OFF	250 kBit/s	125 m	2 x 2 x 0.34
Factory setting					
ON	ON	OFF	125 kBit/s	250 m	2 x 2 x 0.5
OFF	OFF	ON	100 kBit/s	335 m	2 x 2 x 0.75
ON	OFF	ON	50 kBit/s	500 m	on request, dependent on bus configuration
OFF	ON	ON	20 kBit/s	1000 m	
ON	ON	ON	10 kBit/s	1000 m	

The baud rate is set via a code switch. Reduce baud rate if cable is longer than specified in the table. Make sure that all bus nodes have the same settings.

To protect the switching contacts fuse circuit with 2.5 A (anti-surge fuse) or according to TRD regulations (1.0 A for 72 hrs operation).

# Low-Level Limiter / Limiting System Type NRS 1-40

## Technical Data – continued –

### Relay de-energizing delay

Output "Low-level alarm", set to 3 sec. (15 or 25 sec. available for marine applications) internally linked for relay contact test

### Indicators and adjustors

- 4 pushbuttons "Parameterisation/TEST"
- 1 red LED "Low-level alarm electrode 1"
- 1 red LED "Low-level alarm electrode 2"
- 2 red LEDs for multiple functions
- 1 red LED "Bus status"
- 1 green LED "Power"
- 1 ten-pole code switch: 7 poles for setting node ID, 3 poles for setting baud rate
- 1 two-pole code switch for limiter/limiter system

### Internal self-checking routine

Every 3 seconds

### Periodic testing of output relay contacts

Every 6 hours

### Supply voltage

230 V +/- 10 %, 50/60 Hz  
115 V +/- 10 %, 50/60 Hz (optional)

### Power consumption

10 VA

### Sensitivity

≥ 0.5 μS/cm at 25 °C

### Protection

Enclosure: IP 40 to DIN EN 60529  
Terminal strip: IP 20 to DIN EN 60529

### Admissible ambient temperature

0 °C to 55 °C

### Enclosure material

Front panel: polycarbonate, grey  
Enclosure: polycarbonate, black

### Weight

Approx. 0.8 kg

## Order and Enquiry Specification

GESTRA Level Switch type NRS 1-40

Controller .....

Mains voltage ..... V

Level electrode with external chamber ..... (yes/no)

## Ancillary Units

- Conductivity level electrode type NRG 16-40
- Conductivity level electrode type NRG 17-40
- Conductivity level electrode type NRG 19-40
- Conductivity level electrode type NRG 111-40
- Logic control unit type SRL 6 for monitoring purging cycle if external chamber is used

Supply in accordance with our general terms of business.

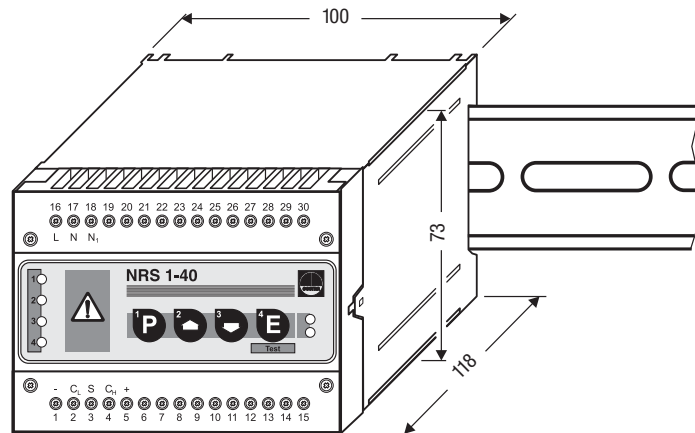
## Dimensions

MAX 55 °C

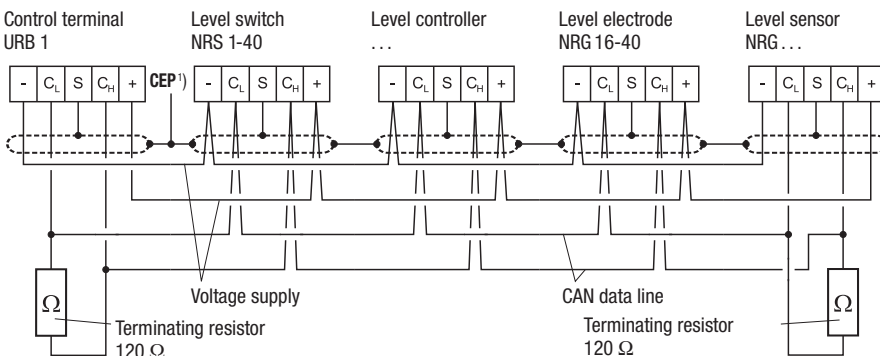
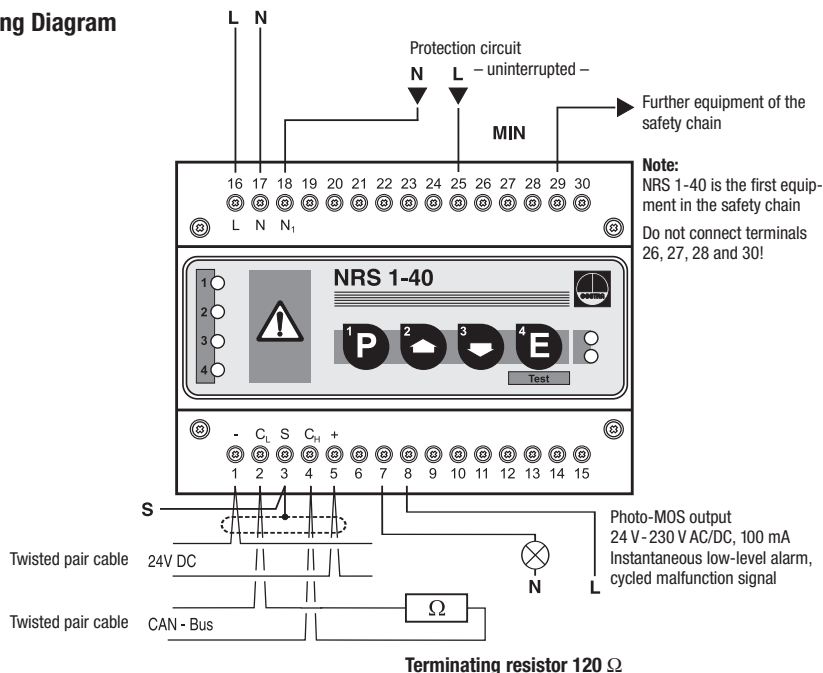
MAX 95 %

IP 20

CE



## Wiring Diagram



1) CEP = central earthing point

# Flowserve GESTRA U.S.

2341 Ampere Drive  
Louisville, KY 40299  
Tel.: 001502 / 2672205, 001502 / 2672206  
Fax: 001502 / 2665397  
Email: dgoodwin@flowserve.com



GESTRA



## GESTRA Steam Systems

## Product Range B

### High-Level Alarm NRS 1-41

### NRS 1-41

#### System Description

##### High-level alarm with one level electrode

The switching controller NRS 1-41 is a self-monitoring high-water level alarm, with automatic routine testing (SMART) feature and output relay monitoring, to be used in conjunction with **one** level electrode type NRG 16-41, 17-41 or 19-41. The switching controller features the following function:

- High-level alarm with **one** switchpoint

The equipment combination detects the max. water level (high-level limiter).

Application in steam boilers and (pressurised) hot-water installations in accordance with TRD 604, sheet 1 and 2 (24/72 hours operation without constant supervision) / EN 12852 and EN 12953.

The equipment complies with the regulations on protection circuits for firing equipment of furnaces DIN VDE 0116 (prEN 50156).

The level data are transferred from the electrode NRG 1...-41 to the switching controller via a designated CAN bus using the CANopen protocol.

#### Function

At regular intervals the level electrode NRG 1...-41 sends a data telegram to the controller NRS 1-41. The data transfer is effected by means of a CAN bus according to DIN ISO 11898. The transferred measuring data are constantly evaluated by the controller. A periodic self-checking routine tests every 3 seconds the integrity of the system and its safety functions, with a malfunction in the controller resulting in immediate boiler shut-down. If the CAN bus line and, consequently, the data transmitting cycle are interrupted, the controller sends a visual signal to indicate a faulty condition and the relays are instantaneously de-energized (normally closed relay outputs). The controller also enables user-friendly performance tests and detection/evaluation of malfunctions.

To guarantee the correct and safe functioning of the high-level limiter a min. electrical conductivity of 0.5 µS/cm at 25 °C is required.

The relay de-energizing delay is normally set to 3 seconds at the factory but delays of 15 to 25 seconds are available on request.

Apart from the burner protection circuit there is also a separate photo MOS make contact output for remote indication.

#### Design

##### NRS 1-41b

Enclosure of insulating material with terminals for installation in control cabinets. The terminals are externally accessible.

Snapping onto a 35 mm standardised supporting rail (DIN EN 50022). External dimensions: 73 x 100 x 118

#### CAN Bus

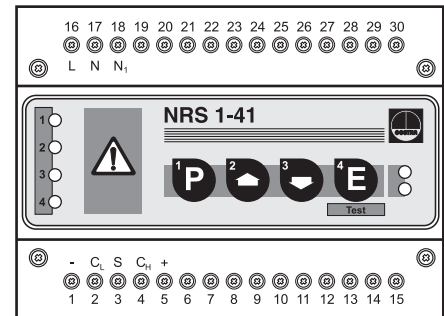
All controllers and associated level electrodes are interconnected by means of a CAN bus using the CANopen protocol. Every item of equipment features an electronic address (node ID). The four-core bus cable serves as power supply and data highway for high-speed data exchange.

The CAN address (node ID) for the NRS 1-41 can be set between **1** and **123**.

The high-level limiter, consisting of **one** level electrode and **one** controller, is configured at our works and ready for service. The high-level limiter can be used straight away without having to set a new node ID.

#### CANopen

The CAN bus of the controller NRS 1-41 uses the CANopen protocol. An Electronic Data Sheet with detailed information on the configuration procedure is available on request.



#### Technical Data

##### Type approval

TÜV-WB-99-403  
EG BAF-MUC 02 02 103881 02

##### Input / Output

Interface for CAN bus to DIN ISO 11898 CANopen

##### Output voltage supply for electrode

18 – 36 V, short-circuit protected

##### Output control circuit

Power supply of level electrode 24 V DC, short-circuit protected

Two volt-free relay contacts, internally connected in series. Max. contact rating with switching voltages of 24 V AC/DC, 115 V AC and 230 V AC: 4 A resistive/inductive.

Contact material Ag Ni 0.15.

##### Interference suppression

Provide contactor with external RC combination (100 Ω / 47nF)

##### Signal output

Photo MOS output, instantaneous high-level alarm, timed malfunction signal, max. contact rating for switching voltages of 24 V AC, 115 V AC and 230 V AC/DC: 100 mA resistive.

##### Relay de-energizing delay

The "High-level alarm" output is factory set to 3 sec. (15 or 25 sec. available for marine applications)

P.T.O.

#### Important Note

Note that screened multi-core twisted-pair control cable is required, e. g. UNITRONIC® BUS CAN 2 x 2 x ...<sup>2</sup> or RE-2YCYV-fl 2 x 2 x ...<sup>2</sup>.

The baud rate (data transfer rate) dictates the cable length between the bus nodes and the total power consumption of the sensor dictates the conductor size.

S 8	S 9	S 10	Baud rate	Cable length	Number of pairs and conductor size [mm <sup>2</sup> ]
OFF	ON	OFF	250 kBit/s	125 m	2 x 2 x 0.34
<b>Factory setting</b>					
ON	ON	OFF	125 kBit/s	250 m	2 x 2 x 0.5
OFF	OFF	ON	100 kBit/s	335 m	2 x 2 x 0.75
ON	OFF	ON	50 kBit/s	500 m	on request, dependent on bus configuration
OFF	ON	ON	20 kBit/s	1000 m	
ON	ON	ON	10 kBit/s	1000 m	

The baud rate is set via a code switch. Reduce baud rate if cable is longer than specified in the table. Make sure that all bus nodes have the same settings.

To protect the switching contacts fuse circuit with 2.5 A (anti-surge fuse) or according to TRD regulations (1.0 A for 72 hrs operation).

# High-Level Alarm NRS 1-41

## Technical Data – continued –

### Indicators and adjustors

- 4 pushbuttons for “parameterisation/Test”
- 1 red LED for “High-level alarm electrode 1”
- 3 red LEDs “Multifunction”
- 1 red LED “Bus status”
- 1 green LED “Power”
- 1 ten-pole code switch, seven poles for node ID, three poles for baud rate settings
- 1 two-pole code switch – without function.

### Do not change the factory settings!

### Internal self-checking routine

Every 3 sec.

### Periodic checking of output relay contacts

Every 6 hours

### Supply voltage

- 230 V +/- 10 %, 50/60 Hz
- 115 V +/- 10 %, 50/60 Hz (optional)
- 24 V +/- 10 %, 50/60 Hz (optional)

### Power consumption

10 VA

### Response sensitivity

From 0.5 µS/cm at 25 °C

### Protection

Case: IP 40 to DIN EN 60529  
Terminal strip: IP 20 to DIN EN 60529

### Admissible ambient temperature

0 – 55 °C

### Enclosure material

Front panel: polycarbonate, grey  
Case: polycarbonate, black

### Weight

Approx. 0.8 kg

## Order and Enquiry Specification

GESTRA Level switch NRS 1-41

Controller .....

Mains supply ..... V

Level electrode with external measuring pot ..... (yes/ no)

## Associated Equipment

- Conductivity level electrode NRG 16-41
- Conductivity level electrode NRG 17-41
- Conductivity level electrode NRG 19-41
- SRL 6 for intermittent blowdown monitoring (for external measuring pot)

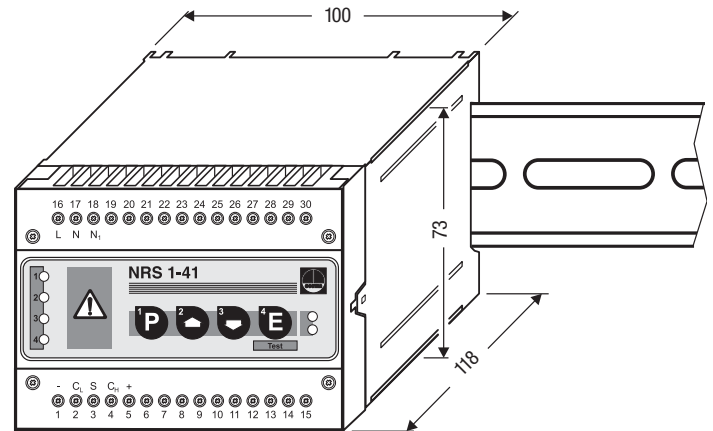
Supply in accordance with our general terms of business.

## Dimensions

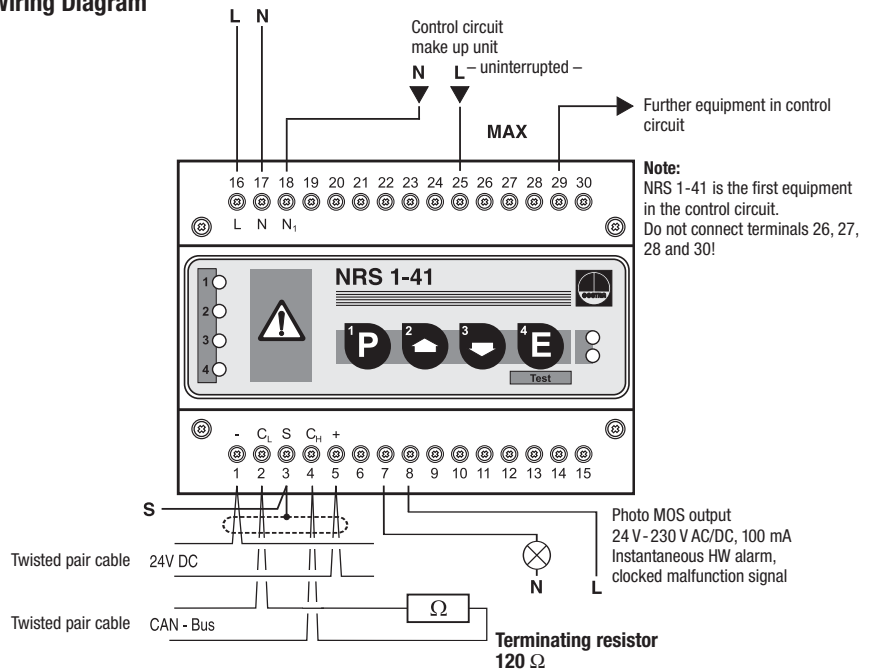
MAX 55 °C

MAX 95 %

IP 20



## Wiring Diagram



**Note:**  
NRS 1-41 is the first equipment in the control circuit.  
Do not connect terminals 26, 27, 28 and 30!

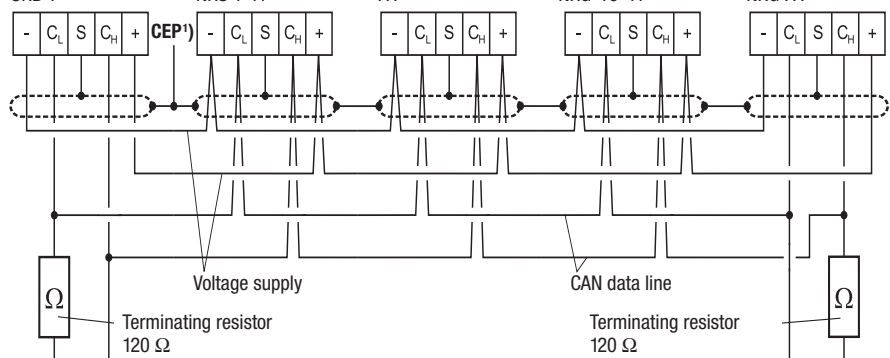
Operating terminal & display unit URB 1

Level switch NRS 1-41

Controller ...

Level electrode NRG 16-41

Level sensor NRG ...



1) CEP = Central earthing point

# Flowserve GESTRA U.S.

2341 Ampere Drive  
Louisville, KY 40299  
Tel.: 001502 / 2672205, 001502 / 2672206  
Fax: 001502 / 2665397  
Email: dgoodwin@flowserve.com



GESTRA

## GESTRA Steam Systems

### Conductivity Monitoring LRGT 16-1

Product Range B

LRGT 16-1



#### Description

The conductivity transmitter LRGT 16-1 is a compact system consisting of a conductivity sensing electrode, a temperature sensor to measure the fluid temperature and a fully integrated conductivity transmitter. The equipment works with two electrodes according to the conductivity measurement principle and provides a conductivity-dependent measuring current of 4 – 20 mA.

The LRGT 16-1 is designed for conductivity monitoring in electrically conductive liquids.

#### Application

Use LRGT 16-1 in conjunction with controller type KS 90 for conductivity monitoring and limiting in steam boilers according to TRD (= German Regulations concerning the design and operation of steam boilers).

The LRGT 16-1 can also be used in combination with an LED analogue display, with a max./min. limit switch or programmable controller for all kinds of process installations.

#### Max. Pressure / Temp. Rating

32 barg (464 psig) / 238 °C (460.4 °F)

#### Design

- Screwed 1" BSP (to DIN ISO 228)

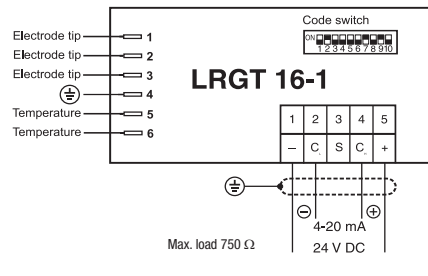
#### Function

A measuring current of variable frequency flows through the fluid, creating a potential gradient between the measuring electrode and the reference tube which is then used as measuring voltage. The electrical conductivity being a function of temperature, a resistance thermometer integrated in the electrode measures the fluid temperatures in order to relate the measured values to the reference temperature.

The electrical conductivity is calculated from the measuring voltages and – as a function of the adjusted temperature coefficient  $T_k$  – linearly based on the reference temperature of 25 °C. Once converted into a conductivity-dependent current signal, an output current of 4 - 20 mA is available for external use. The cables leading to the measuring electrode, the reference tube and the resistance thermometer are monitored and checked for interruptions and short circuits. The circuit board is protected against excess temperatures in the terminal box. Should a malfunction occur, the LEDs on the circuit board will light up or flash and the current signal is set to 0 or 1.5 mA.

A ten-pole code switch enables the parameterisation of the transmitter, the adaptation of the cell constant and the activation of a performance test.

#### Wiring Diagram



#### Technical Data

##### Type approval

TÜV-WÜL-01-003  
EG BAF-MUC 01 04105620 001

##### Max. service pressure

32 barg (464 psig) at 238 °C (460.4 °F)

##### Connection

Screwed 1" BSP (to DIN ISO 228)

##### Materials

Body: 3.2161 G AISi8Cu3  
Stem: 1.4571 CrNiMoTi17-12-2  
Electrode: 1.4571 CrNiMoTi17-12-2  
Insulating bushes: PEEK  
Electrode stabiliser: PTFE

##### Temperature sensor

Resistance thermometer Pt 1000

##### Cell constant

$C = 0.2 \text{ cm}^{-1}$

##### Temperature coefficient

1.6 % / °C to 3 % / °C (adjustable)

##### Measuring range

Adjustable measuring range (control range) [µS/cm] at 25 °C	
0.5	to 20
0.5	to 100
0.5	to 200
0.5	to 500
0.5	to 1000
0.5	to 2000
0.5	to 6000
0.5	to 12000

##### Output

4 – 20 mA, 4 mA  $\pm$  0.5 µS/cm,  
20 mA  $\pm$  Limit of measuring range

##### Fuse

Thermal fuse  $T_{max} = 85 \text{ °C}$

##### Power consumption

4.5 W

##### Cable entry

Cable gland with integral cable clamp  
2 x M 20 (PG 16)

##### Protection

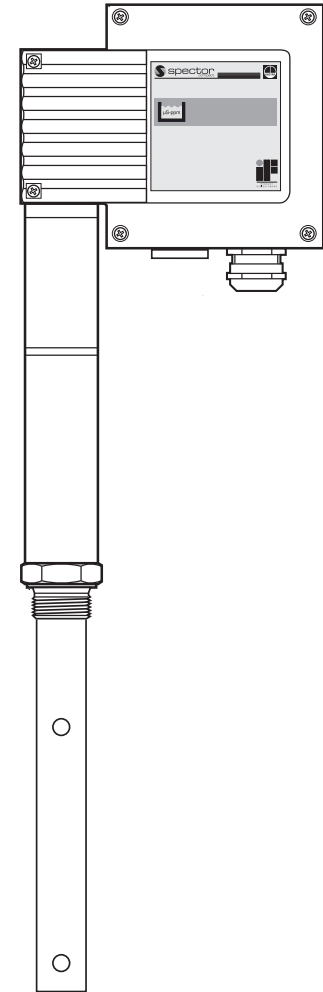
IP 65 to DIN 40050

##### Max. admissible ambient temperature

70 °C

##### Approx. weight

2.5 kg



# Conductivity Monitoring LRGT 16-1

## Important Notes

The conductivity transmitter LRGT 16-1 must operate from a 24 V DC safety PSU as per DIN VDE 0106. The power supply unit has to be equipped with an excess current protective device as specified in DIN EN 61010-1/ VDE 0411.

Cable required for wiring: Flexible, screened control cable, min. conductor size 0.75 mm<sup>2</sup>.

Max. cable length: 250 m

When mounting the electrode into steam or pressurised hot-water boilers the relevant regulations must be considered.

## Order and Enquiry Specification

GESTRA Conductivity Transmitter LRGT 16-1

## Associated Controller

- GESTRA Control unit KS 90

## Ancillary Units

- Max./min. limit switch URS 2
- Max./min. limit switch/display unit PAX
- Bar-chart indicator URA/ARZ

- A** Flange PN 40, DN 50, DIN EN 1092-1  
Flange PN 40, DN 100, DIN EN 1092-1
- B** For the approval of the boiler standpipe with connecting flange the relevant regulations must be considered.
- C** Electrode rod  $d = 25$  mm

Lengths supplied <b>D</b>	Measuring lengths	Possible reduction of lengths
215 mm	200 mm	
315 mm	300 mm	50 mm
415 mm	400 mm	50 mm
515 mm	500 mm	50 mm
615 mm	600 mm	50 mm
815 mm	800 mm	100 mm
1015 mm	1000 mm	100 mm



The LRGT 16-1 is in conformity with the European EMC Directive and the EC Pressure Equipment Directive (PED).

Supply in accordance with our general terms of business.

## Dimensions

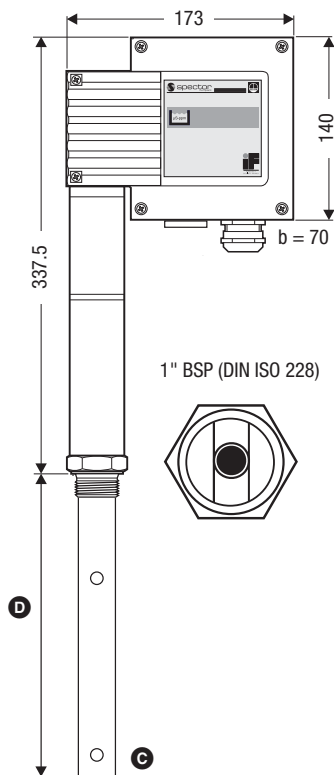
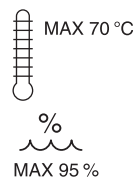


Fig. 1 LRGT 16-1



IP 65



**Do not insulate electrode!**

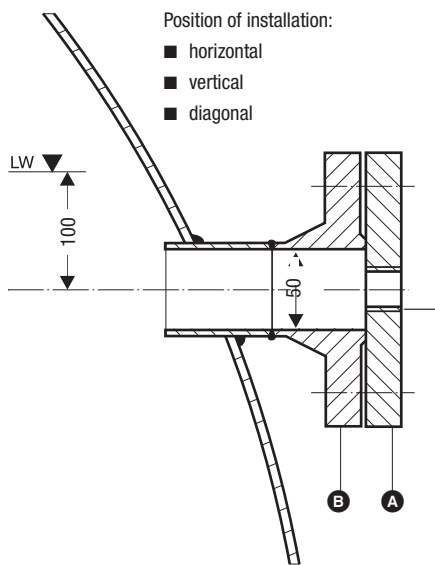


Fig. 2 Boiler standpipe, horizontal installation

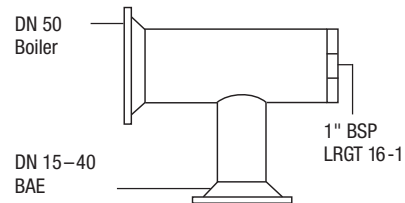


Fig. 3 Installation with tee-piece

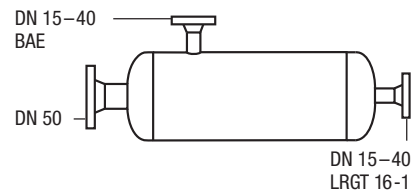


Fig. 4 Installation in measuring pot

# Flowserve GESTRA U.S.

2341 Ampere Drive  
Louisville, KY 40299  
Tel.: 001502 / 2672205, 001502 / 2672206  
Fax: 001502 / 2665397  
Email: dgoodwin@flowserve.com



GESTRA

## GESTRA Steam Systems

Product Range B

### Conductivity Electrode LRG 16-40 CAN-Bus CANopen

### LRG 16-40

#### Description

The conductivity sensing electrode LRG 16-40 consists of a TDS (= Total Dissolved Solids) monitoring electrode for conductivity measurement, a temperature sensor for detecting the fluid temperature and a fully integrated conductivity (TDS) transmitter. The equipment makes use of two electrodes and works according to the conductometric measurement principle. The temperature compensated conductivity (TDS) data are transmitted via a designated CAN data bus using the CANopen protocol to the control unit or another system component.

The conductivity electrode is used to measure the actual TDS level and, consequently, the electrical conductivity in electrically conductive liquids.

#### Application

Use conductivity (TDS) electrode LRG 16-40 in conjunction with TDS controller LRR 1-40 and control terminal and display unit URB 1 for conductivity (TDS) monitoring, control and limitation in steam generating units and boilers in accordance with TRD.

#### Max. Pressure/Temperature Rating

32 barg (464 psig) / 238 °C (460.4 °F)

#### Design

■ LRG 16-40, screwed 1" BSP to DIN ISO 228

#### Function

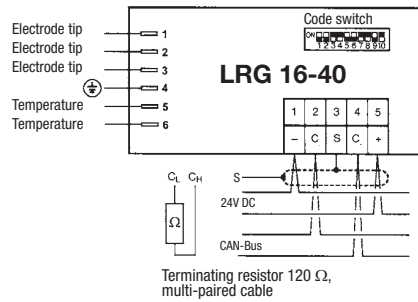
A measuring current of variable frequency flows through the fluid, creating a potential gradient between the measuring electrode and the reference tube which is then used as measuring voltage. The electrical conductivity being a function of temperature, a resistance thermometer integrated in the electrode measures the fluid temperature in order to relate the measured values to the reference temperature.

The electrical conductivity is calculated from the measuring voltages and – as a function of the adjusted temperature coefficient  $T_k$  (LRR 1-40) – is based on the reference temperature of 25 °C. The data are transmitted via a designated CAN bus using the CANopen protocol according to DIN ISO 11898.

The cables leading to the measuring electrode, the reference tube and the resistance thermometer are monitored and checked for interruptions and short circuits. The circuit board is protected against excessively high temperatures in the terminal box. Should a malfunction occur, the LEDs on the circuit board will light up or flash.

A ten-pole code switch enables the parameterisation of the transmitter, the adaptation of the cell constant and the activation of a performance test.

#### Wiring Diagram



#### Technical Data

**Type approval**  
TÜV · WÜL · 02-007  
BAF-MUC 0205 103881 003

**Max. service pressure**  
32 barg at 238 °C

**Connection**  
Screwed 1" BSP to DIN ISO 228

**Materials**  
Body: 3.2161 G AISi8Cu3  
Stem: S. S. 1.4571 CrNiMoTi17-12-2  
Electrode: S. S. 1.4571 CrNiMoTi17-12-2  
Spacer disc: PEEK  
Electrode stabiliser: PTFE

**Temperature sensor**  
Resistance thermometer Pt 1000

**Cell constant**  
 $C = 0.2 \text{ cm}^{-1}$

**Fuse**  
Thermal fuse  $T_{\text{max}} = 85 \text{ °C}$ ,  
hysteresis  $-2 \text{ K}$

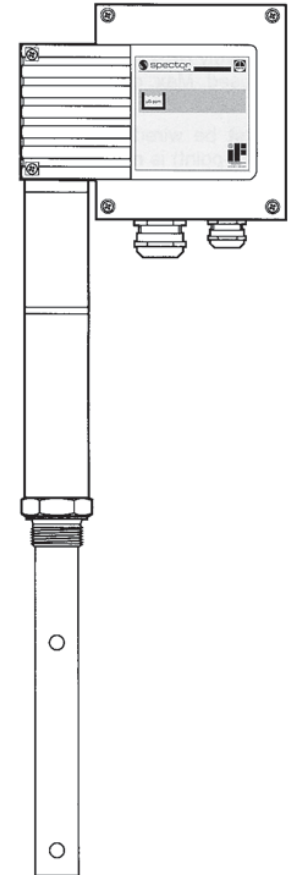
**Power consumption**  
3 W

**Cable entry**  
Cable gland with integral cable clamp  
PG 9 (M 16)  
PG 16 (M 20)

**Protection**  
IP 65 to DIN 40050

**Max. admissible ambient temperature**  
70 °C

**Approx. weight**  
2.5 kg



Conductivity Electrode  
**LRG 16-40**  
**CAN-Bus**  
**CANopen**

**Important Notes**

Note that multi-paired control cable, e. g. UNITRONIC® Bus CAN 2 x 2 x ...mm<sup>2</sup> **must** be used. Alternatively RE-2YCYV-fl 2 x 2 x ...mm<sup>2</sup> can also be used. Max. cable length 125 m at 250 kBit/s.

The bus **must** be wired in series. Star-type wiring (point-to-point) is **not** permitted.

Standard values for cable lengths between two bus-based devices (length of segment) and for conductor sizes as specified in ISO 11898:

Length of segment [m]	Number of pairs and conductor size [mm <sup>2</sup> ]
up to 300	2 x 2 x 0.34
300 to 600	2 x 2 x 0.5
600 to 1000	2 x 2 x 0.75

**Order and Enquiry Specification**

GESTRA Conductivity Electrode LRG 16-40

**Associated Control Units**

- Blowdown (TDS) controller LRR 1-40
- Control terminal and display unit URB 1

**Ancillary Unit**

(for optional actual value output)

- Max./min. limit switch URS 2
- Max./min. limit switch / display unit PAX
- Bar-chart indicator URA/ARZ

- Ⓐ Flange PN 40, DN 50, DIN 2527  
Flange PN 40, DN 100, DIN 2527

- Ⓑ For the approval of the boiler standpipe with connecting flange the relevant regulations must be considered.

- Ⓒ Electrode rod d = 25 mm

Ⓓ Lengths supplied	Measuring lengths	Possible reduction of length
215 mm	200 mm	
315 mm	300 mm	50 mm
415 mm	400 mm	50 mm
515 mm	500 mm	50 mm
615 mm	600 mm	50 mm
815 mm	800 mm	100 mm
1015 mm	1000 mm	100 mm



The LRG 16-40 is in conformity with the European EMC Directive and the EC Pressure Equipment Directive (PED).

Supply in accordance with our general terms of business.

**Dimensions**

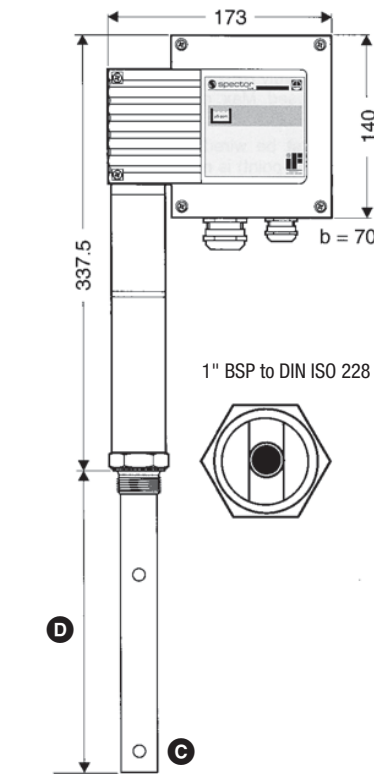
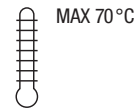


Fig. 1 LRG 16-40



**⚠ Do NOT insulate electrode!**

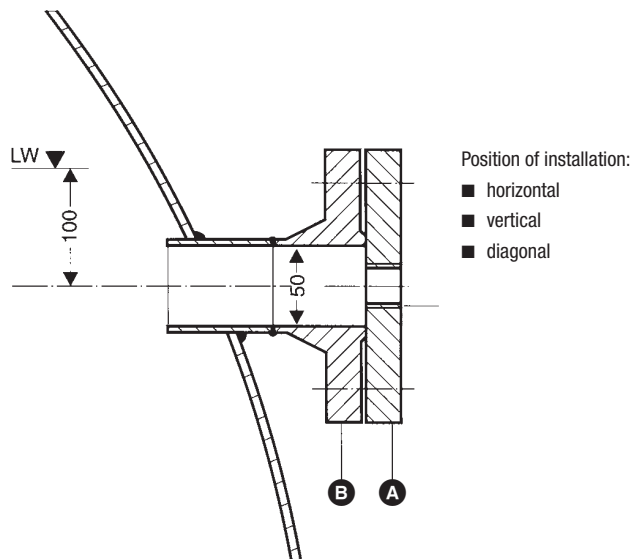


Fig. 2 Boiler standpipe, horizontal installation

**Flowserve GESTRA U.S.**

2341 Ampere Drive  
 Louisville, KY 40299  
 Tel.: 001502 / 2672205, 001502 / 2672206  
 Fax: 001502 / 2665397  
 Email: dgoodwin@flowserve.com



GESTRA

## GESTRA Steam Systems

### Conductivity Electrodes

#### ERL 16

#### LRG 16

#### Description

##### Conductivity Monitoring

Continuous monitoring of boiler water for increase in density (TDS control) with the GESTRA conductivity limit switch type LRS. Monitoring of the condensate returned to the boiler to detect any ingress of acids, alkalis etc.

Application mainly in steam boiler plants operating without constant supervision (TRD 604) for condensate monitoring, as well as in district heating plants, paper and woodworking industries, catering kitchens, for dyebath monitoring in dye works, for conductivity monitoring in water treatment plants.

##### Continuous Blowdown Control

Used in conjunction with GESTRA continuous blowdown controller type LRR 1-5/LRR 1-6/LRR 1-10 and GESTRA continuous blowdown valve type BAE for fully automatic blowdown control. Accurate TDS control increases the operational safety of the plant, reduces water consumption and effluent disposal charges and saves energy by reducing the blowdown rate to the minimum. Automatic isolation of blowdown line on boiler shut-down.

#### Function

The electrode is positioned so that it continuously senses the boiler water condition and can take a direct conductivity reading. The electrical conductivity produces a proportional current provided that measuring surface and voltage supply remain constant.

#### Design

The conductivity electrodes are provided with an electrode rod completely insulated by a PTFE sleeving except for the measuring surface. A pressure-tight sealing between electrode rod and body is ensured by a Teflon tube.

The electrode tip of the LRG 16-4 can be shortened back by 200 mm (for details see "Installation and Service Instructions").

The electric connection is carried out via a four-pole connector.

The following designs are available:

- Conductivity electrode type ERL 16-1 with screwed connection, 1/2" BSP, (1/2" NPT available on request), for sandwiching between wafer-type mounting flange 1/2" BSP, DN 15, 20, 25, 40 mm, for direct connection to the continuous blowdown valve.
- Conductivity electrode type ERL 16-1 with screwed connection 3/4" BSP; installation on a side connection (measuring pot) is highly recommended.
- Conductivity electrode type LRG 16-4 for flanged connection PN 40 (see "Technical Data") for installation in the boiler shell or on a side connection.
- Conductivity electrode type LRG 16-4 for installation in a tee piece specially designed for a side connection of the boiler, DN 15 – 40 mm. The blowdown line is directly connected to the measuring pot.

#### Technical Data

##### Max. service pressure

32 barg (465 psig) at saturation temperature 238 °C (higher pressures available on request)

##### Connection

ERL 16-1: Screwed 1/2" or 3/4" BSP (screwed NPT on request), PN 40 to DIN 228

Flanged DN 50, PN 40, DIN 2527, for marine application  
Four inspection certificates

Flanged DN 100, PN 40, DIN 2527, inspection to 3.1 B

Square flange DN 100, PN 40  
□ 128 mm, inspection to 3.1 B

LRG 16-4: With tee piece for side connection of the boiler, DN 15 – 40, Screwed 3/8", DIN 228 – optional –

Flanged DN 50, PN 40, DIN 2527

Tee piece DN 15 – 40, PN 40, DIN 2527

##### Lengths L supplied (see "Dimensions")

ERL 16-1 (screwed 3/4" BSP): 99 mm

LRG 16-4: 300, 400, 500, 600, 800, 1000 and 1200

##### Materials

Body ERL 16-...: X 6 CrNiMoTi 17 12 2 (1.4571)

Body LRG 16-4: X 6 CrNiMoTi 17 12 2 (1.4571)

Tee-piece for LRG 16-4: C 22.8/St. 35.8

Electrode rod: X 6 CrNiMoTi 17 12 2 (1.4571)

Electrode tip: X 6 CrNiMoTi 17 12 2 (1.4571)

Insulating sleeving: PTFE

Terminal box and connector: plastics

##### Permissible conductivity range

From 1 µS/cm

##### Max. permissible ambient temperature at terminal box

60 °C

##### Electric connection

Via four-pole connector with screw terminals, cable strain relief and cable gland Pg 11

##### Approx. weight (with max. length L)

ERL 16-1: 0.9 kg

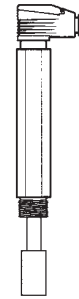
Mounting flange (screwed 1/2" BSP): 1.4 kg

LRG 16-4: 0.5 kg

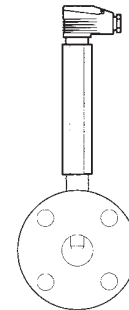
## Product Range B1

### ERL 16

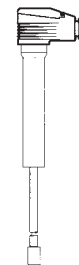
### LRG 16



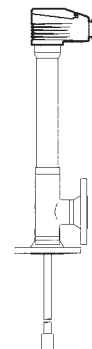
Conductivity electrode ERL 16-1, 3/4"



Conductivity electrode ERL 16-1, 1/2", with mounting flange



Conductivity electrode LRG 16-4



Conductivity electrode LRG 16-4 with tee piece

### Important Notes

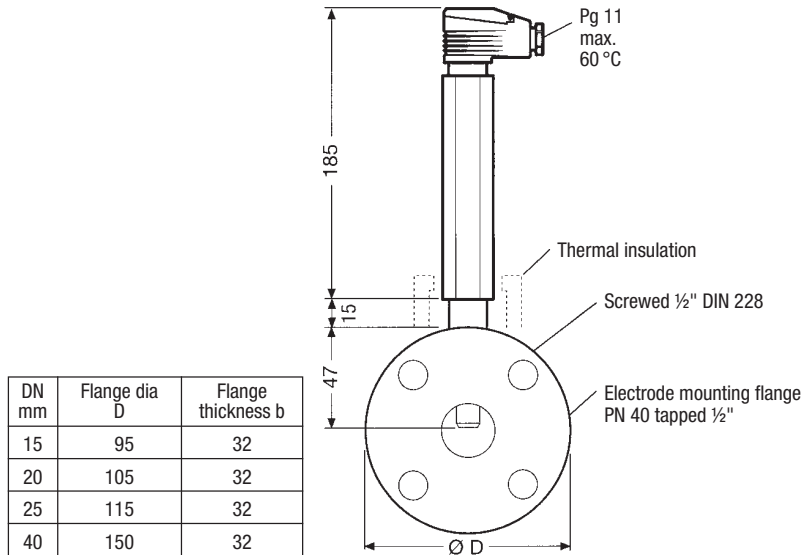
Cable required for wiring: screened cable, e.g. 2 x 2 x 0.8 or 4 x 0.5 mm<sup>2</sup>; For cable length see data sheet of the associated electronic control unit.

The conductivity electrode type ERL 16, ½", is provided with a wafer-type mounting flange for direct connection to the continuous blowdown valve type BAE.

The conductivity electrode type LRG 16-4 is used with a tee piece. The continuous blowdown line is connected to the tee piece, i. e. the conductivity is measured, even if the blowdown valve is closed.

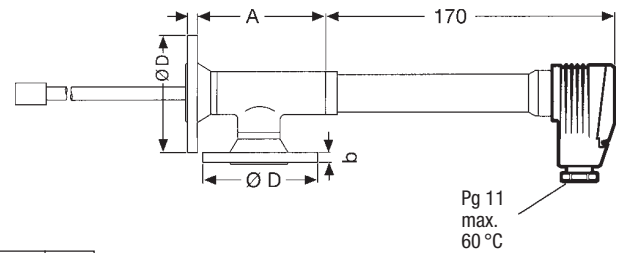
The conductivity electrode can be installed vertically, horizontally or radially inclined. The electrode tip must be constantly submerged by at least 100 mm.

When mounting the electrode into steam or pressurized hot water boilers the relevant regulations must be considered.



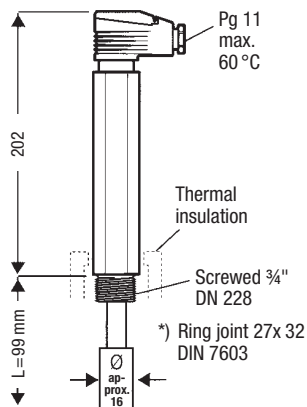
DN mm	Flange dia D	Flange thickness b
15	95	32
20	105	32
25	115	32
40	150	32

Conductivity electrode type ERL 16-1 with wafer-type mounting flange, PN 40, DIN 2527

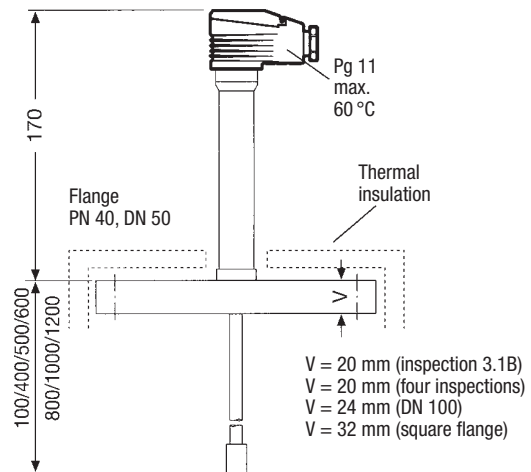


DN mm	Flange dia D	Flange thickness b	A
15	95	18	118
20	105	18	129
25	115	18	137
40	150	18	180

Conductivity electrode type LRG 16-4 with tee-piece



Conductivity electrode type ERL 16-1, ¾"

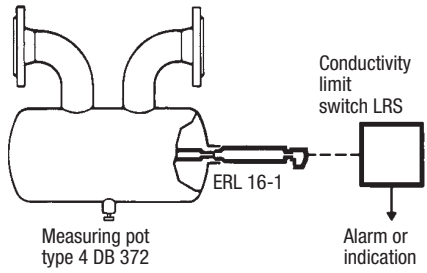


Conductivity electrode type LRG 16-4 with flange DN 50, PN 40, DIN 2527

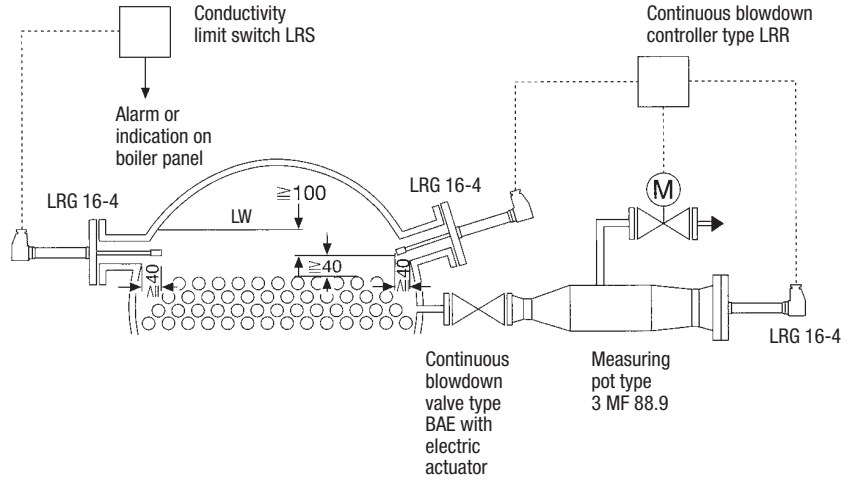
- V = 20 mm (inspection 3.1B)
- V = 20 mm (four inspections)
- V = 24 mm (DN 100)
- V = 32 mm (square flange)



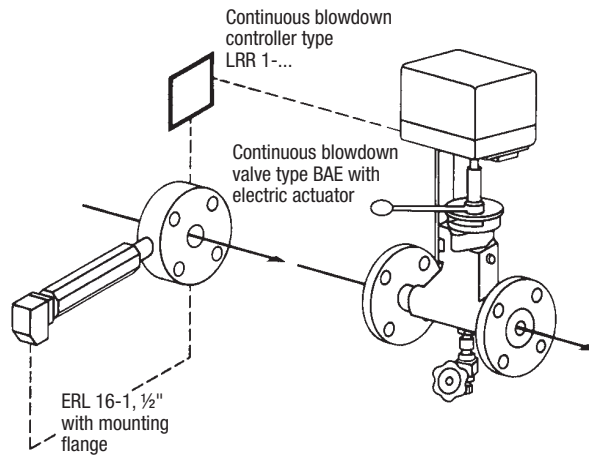
**Examples of Installation**



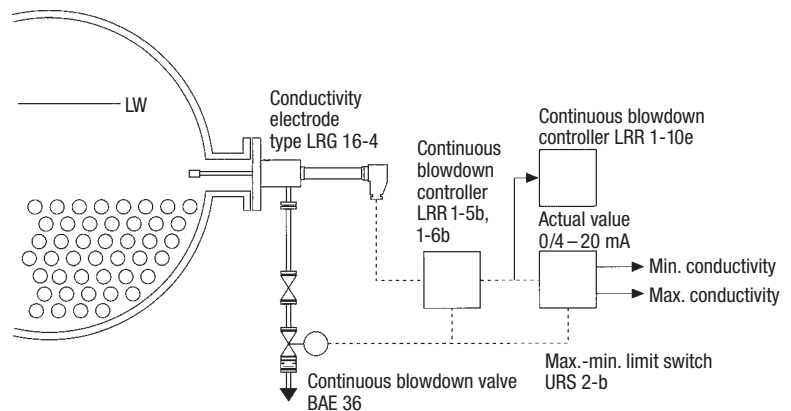
Horizontal installation of conductivity electrode type ERL 16-1 in a measuring pot. Application for condensate monitoring.



Left-hand side horizontal installation of conductivity electrode type LRG 16-4 in a boiler drum, right-hand side installation of LRG 16-4 inside the boiler and outside in a measuring pot



Fitting of conductivity electrode type ERL 16-1 with wafer-type mounting flange to BAE



Conductivity electrode type LRG 16-4 with tee-piece fitted directly to the boiler drum

\*)

## Conductivity Electrodes

### ERL 16

### LRG 16

#### Order and Enquiry Specifications

GESTRA conductivity electrode as sensor for conductivity monitoring or continuous blowdown control:

Conductivity electrode type ERL 16-1, PN 40, with screwed connection ½" BSP (DIN 228), Length supplied L = 47 mm  
Electrode mounting flange ½", DN ...

or

Conductivity electrode type ERL 16-1, PN 40, with screwed connection ¾" BSP (DIN 228), Length supplied L = 99 mm

or

Conductivity electrode type LRG 16-4, PN 40, with flanged connection DN ....., DIN 2527 or Square flange, Length supplied L = ..... mm  
Inspection

or

Conductivity electrode type LRG 16-4, PN 40, with tee piece, DN ....

#### The following test certificates can be issued on request, at extra cost:

In accordance with EN 10204-2.1, -2.2 and -3.1B.  
All inspection requirements have to be stated with the order. After supply of the equipment certification cannot be established. For tests and inspection charges please consult us.

#### Associated Equipment

For conductivity monitoring:  
Conductivity limit switch type LRS.

For continuous blowdown control:  
Continuous blowdown controller type LRR 1-5b or LRR 1-6b, max.-min. limit switch type URS 2b, bar-chart indicator type URA 1e or 2e, continuous blowdown valve BAE or blowdown controller LRR 1-10e.

Supply in accordance with our general terms of business.

## Flowserve GESTRA U.S.

2341 Ampere Drive  
Louisville, KY 40299  
Tel.: 001502 / 2672205, 001502 / 2672206  
Fax: 001502 / 2665397  
Email: dgoodwin@flowserve.com



GESTRA

## GESTRA Steam Systems

### Conductivity Electrodes LRG 17, LRG 19

Product Range B1

### LRG 17 LRG 19

#### Purpose and Application

##### I Monitoring of Conductivity

Continuous monitoring of boiler water for increase in density with the GESTRA conductivity controller type LRS.

Application in steam boilers, in particular plants operated automatically, e. g. in accordance with the regulations for operation without constant supervision (TRD 604).

##### II Continuous Blowdown Control

Automatically controlled continuous blowdown to reduce blowdown wastage and increase the operating safety with the GESTRA continuous blowdown controller type LRR 1-5 and the GESTRA continuous blowdown valve type BAE. Automatic closing of blowdown line during boiler shut-down.

#### Design

The conductivity electrodes types LRG 17 and LRG 19 are provided with an electrode rod completely insulated by a PTFE tubing with the exception of the measuring tip. A system of compression springs ensures a pressure-tight sealing between flange and electrode rod even at varying temperatures.

The following designs are available:

Conductivity electrode type LRG 17-1 with flanged connection, PN 63, DN 50 mm or flanged ANSI 400/600, 2".

Conductivity electrode type LRG 19-1 with flanged connection, PN 63, DN 50 mm or flanged ANSI 900/1500, 2".

Installation inside the steam boiler or outside into a measuring pot.

#### Operation

For monitoring the boiler water, its conductivity is used. The conductivity produces a proportional current if measuring surface and voltage supply remain constant.

#### Technical Data

##### Max. service pressure

LRG 17-1: 63 bar g (915 psig) at 120 °C,  
60 barg (870 psig) at saturation  
temperature 275°C

LRG 19-1: 160 bar g (2320 psig) at 120 °C,  
60 barg (870 psig) at saturation  
temperature 275°C

##### Connection

LRG 17-1: Flanged DIN PN 63, DN 50 mm  
or  
flanged ANSI 400/600 2"  
inspection to 3.1 B

LRG 19-1: Flanged DIN PN 160, DN 50 mm  
or  
flanged ANSI 900/1500 2"  
inspection to 3.1 B

#### Materials

Body: 15 Mo 3 (DIN No. 1.5415)  
Electrode rod: X 6 CrNiMoTi 17 12 2 (1.4571)  
Insulating tubing: PTFE

#### Cell constant of electrode

C = 1.0 [1/cm]

#### Max. permissible ambient temperature at terminal box

60 °C

#### Protection terminal box

IP 54

#### Electric connection

in the terminal box with screw terminals,  
cable strain relief and cable gland Pg 11

#### Approx. weight

LRG 17-1: 9 kg  
LRG 19-1: 10 kg

#### Important Notes

Cable required for wiring: Screened cable, e.g. 4 x 0.5 mm<sup>2</sup>, max. cable length 50 m.

The conductivity electrode may be installed vertically or inclined up to 85°.

The electrode tip must be constantly submerged, which has to be taken into account when installing electrode.

When mounting the electrode into steam or pressurized hot water boilers the relevant regulations must be considered.

Explosion protection for zone 1 is possible on request by connecting Zener barriers.

#### Order and Enquiry Specifications

GESTRA conductivity electrode as sensor for conductivity monitoring or continuous blowdown control:

Conductivity electrode type LRG 17-1,  
with flanged connection, PN 63, DN 50 mm or flanged  
ANSI 400/600, 2"

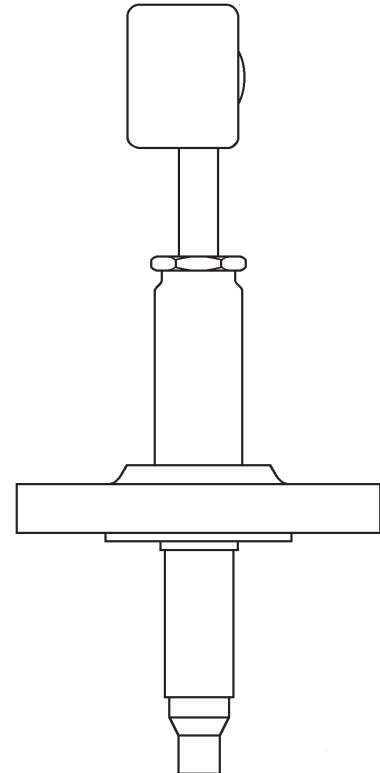
or

Conductivity electrode type LRG 19-1,  
with flanged connection, PN 160, DN 50 mm or flanged  
ANSI 900/1500, 2".

#### The following test certificates can be issued on request, at extra cost:

In accordance with DIN 50049-2.1, -2.2 and -3.1 B.

All inspection requirements have to be stated with the order. After supply of the equipment certificates can no longer be established. Charges and extent of the above mentioned certificates as well as the different tests confirmed therein are listed in our leaflet "Test and Inspection Charges for Standard Equipment". For other tests and inspections than those listed above, please consult us.



Conductivity electrode  
LRG 17-1, LRG 19-1

# Conductivity Electrodes LRG 17, LRG 19

## Associated Equipment

for conductivity monitoring:  
Conductivity controller type LRS 1-...  
For continuous blowdown control:  
Continuous blowdown controller type LRR 1-...  
continuous blowdown valve type BAE.

## Installation and Service Instructions

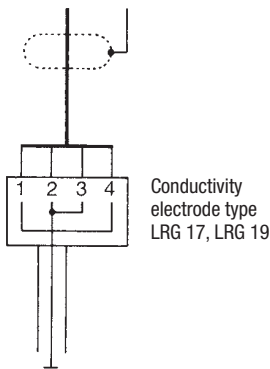
The electrodes are measuring probes and should be handled with care. Avoid subjecting electrode tip to shocks.

## Installation

Mount conductivity electrode on boiler or vessel stand-pipe.  
The electrode body situated above the flange must not be insulated.

## Wiring

Always use screened cable for wiring.



### Wiring the terminal box

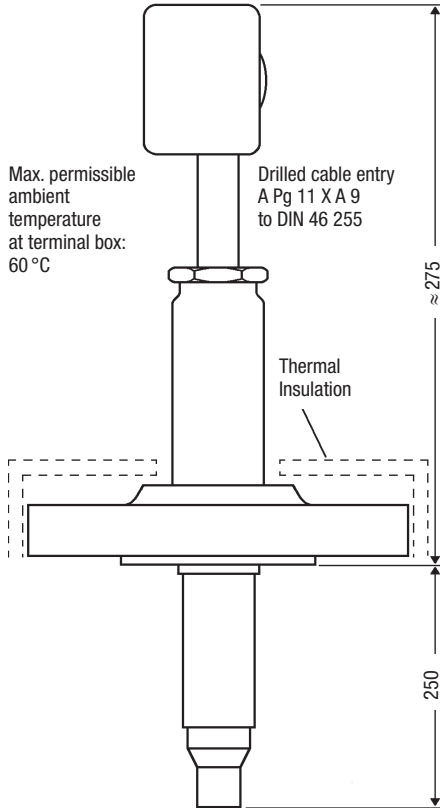
(For wiring to the electronic unit see corresponding data sheets.)

## Maintenance

The electrode does not require any particular maintenance. It is, however, recommended to check the electrode tip every six months. Cleaning is possible by rubbing of the tip with emery paper.

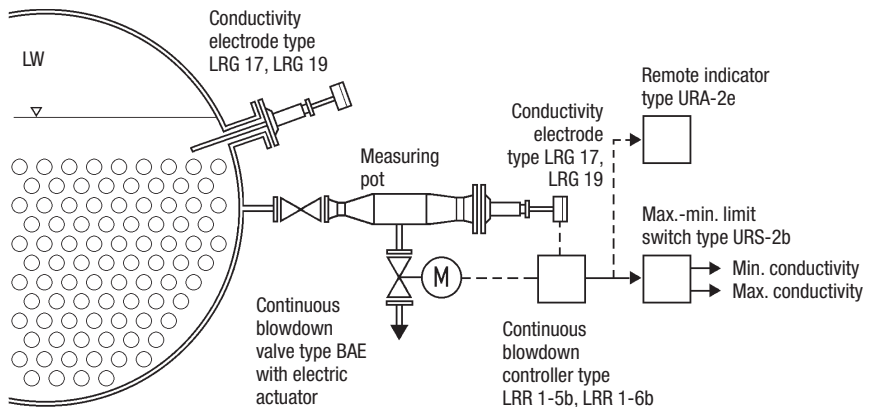
Supply in accordance with our general terms of business.

## Dimensions



Conductivity electrode type LRG 17-1, LRG 19-1

## Example of Installation



Installation of conductivity electrodes types LRG 17, LRG 19 in a measuring pot

# Flowserve GESTRA U.S.

2341 Ampere Drive  
Louisville, KY 40299  
Tel.: 001502 / 2672205, 001502 / 2672206  
Fax: 001502 / 2665397  
Email: dgoodwin@flowserve.com



GESTRA

## GESTRA Steam Systems

### Conductivity Limit Switches LRS 1-5b, LRS 1-6b

Product Range B1

### LRS 1-5b LRS 1-6b

#### Purpose and Application

Continuous monitoring of the conductivity of liquids with the GESTRA conductivity electrode types ERL 16, LRG 16-4, LRG 17 or LRG 19. Signalling of preselected conductivity limit value.

Application in steam boiler plants for feedwater and condensate monitoring; for condensate monitoring in district heating plants, in the paper and pulp industry and in catering kitchens; for conductivity monitoring in water treatment plants; for monitoring of cooling towers; for dyebath monitoring in dye works.

#### Design

Plug-in unit in plastic case for installation in control cabinets. The terminals in the case are accessible after loosening two screws and unplugging the unit from its base. To avoid confusion with other plug-in units of the GESTRA range, inserts are fitted in the bases so that only the correct unit may be plugged into each base.

The plug-in units may be snapped onto a 35 mm supporting rail or screwed into position on a mounting panel.

Field enclosures for several plug-in units are available on request.

#### Technical Data

##### Function

Measuring transducer with switch contact for conductivity used with the conductivity electrode types ERL 16, LRG 16-4, LRG 17 or LRG 19, manual temperature compensation at operating point.

##### Input

Four connections for one conductivity electrode ERL or LRG

##### Output

1 volt-free relay contact;  
max. contact rating: 250 V, 500 W, 3 A resistive with a life of  $4 \times 10^5$  switching cycles or 0.35 A inductive with a life of  $2 \times 10^6$  cycles;  
contact material silver, hard-gold plated

##### Limit value

Continuously adjustable within the respective range  
0.4...10 mS/cm or 0.04...1 mS/cm for LRS 1-5b,  
4...100  $\mu$ S/cm or 0.4...10  $\mu$ S/cm for LRS 1-6b

Selection between the two ranges by switch on front panel, values referred to 25 °C

Temperature influence can be compensated with the aid of adjuster up to max. 250 °C on reaching service temperature, initial position calibrated to 25 °C

##### Switching hysteresis

1 %

##### Indicators

Two LEDs: green for  $\sigma <$  limit value  
red for  $\sigma >$  limit value

##### Cell constant of conductivity electrode

$C = 1.0 [1/cm]$

##### Electrode supply voltage

Delta voltage  $0.5 V_p/1000$  Hz for LRS 1-5b  
Delta voltage  $1.3 V_p/67$  Hz for LRS 1-6b

##### Mains supply

120 V/60 Hz, 220 V/50 Hz, 240 V/50 Hz, 3.5 VA  
(please state voltage when ordering)

#### Protection

IP 40

#### Permissible ambient temperature

0...55 °C

#### Case materials

Base: ABS plastic, black  
Cover: ABS plastic, stone-grey

#### Weight

Approx. 0.5 kg

#### Important Notes

Cable required for wiring to the electrode:  
Screened cable, e.g.  $4 \times 0.8$  mm<sup>2</sup>, cable length see table in "Installation and Service Instructions".

#### Order and Enquiry Specifications

GESTRA conductivity limit switch as measuring transducer with switch contact used with the GESTRA conductivity electrode types ERL or LRG:

Conductivity limit switch type LRS 1-..., plug-in unit in plastic case for installation in control cabinets

Mains supply ..... V

#### Associated Conductivity Electrodes

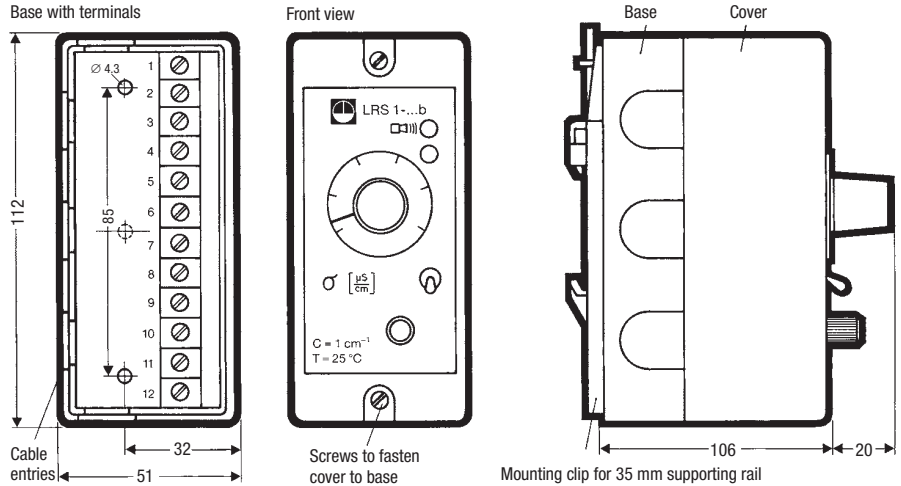
Conductivity electrode types  
ERL 16-... or LRG 16-4, PN 40  
LRG 17-1, PN 63 or  
LRG 19-1, PN 160



Conductivity limit switch LRS 1-5b, LRS 1-6b

# Conductivity Limit Switches LRS 1-5b, LRS 1-6b

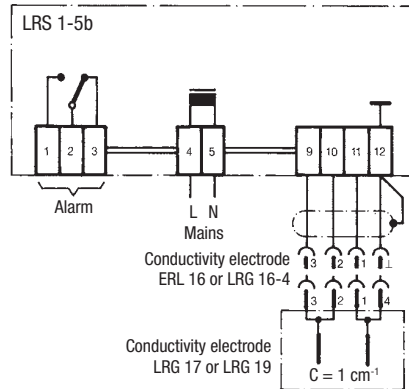
## Dimensions



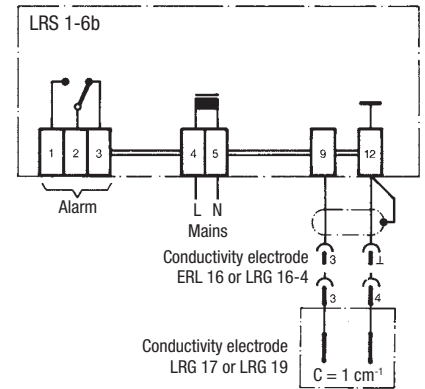
- ⌀ 4.3 holes to be drilled to 4.3 mm dia for installation of unit in boiler panel
- ⌀ hole drilled for mounting clip

Dimensions of conductivity limit switch types LRS 1-5b, LRS 1-6b

## Wiring Diagrams



Wiring diagram for conductivity limit switch type LRS 1-5b, illustrated position of contact: relay de-energized, i.e. alarm



Wiring diagram for conductivity limit switch type LRS 1-6b, illustrated position of contact: relay de-energized, i.e. alarm

Supply in accordance with our general terms of business.

## Flowserve GESTRA U.S.

2341 Ampere Drive  
Louisville, KY 40299  
Tel.: 001502 / 2672205, 001502 / 2672206  
Fax: 001502 / 2665397  
Email: dgoodwin@flowserve.com



GESTRA

## GESTRA Steam Systems

Product Range B1

### Conductivity Electrode Type LRG 12-2

### LRG 12-2

#### Purpose and Application

Conductivity monitoring of process or boiler water with the LRG 12-2 in conjunction with boiler blowdown controller type LRR 1-10.

The conductivity electrode type LRG 12-2 is designed for use with the conductivity controller type LRR 1-10 and the continuous blowdown valve type 510 or BAE 36.

Application of this equipment combination mainly in plants operated automatically, e.g. in accordance with the regulations for operation without constant supervision (TRD 604).

#### Configuration

The conductivity electrode type LRG 12-2 consists of an electrode case with integrated measuring sensor. A measuring chamber matched to the system is incorporated in the electrode housing.

The measuring sensor, consisting of the electrode, insulating sleeve and pressure disk, is pressed into the electrode housing, thus ensuring pressure-tight sealing. The interference fit guarantees adequate tightness even with varying temperatures.

#### Design

Conductivity electrode type LRG 12-2 with measuring chamber PN 16, DN ½".

#### Operation

For monitoring liquids, its electric conductivity is used.

The measuring current produced in the LRR 1-10 is fed to the measuring sensor and flows through the fluid.

On account of the constant measuring surface and the defined measuring volume a measuring current proportional to the conductivity is established between the electrode housing and the measuring sensor. This current is evaluated by the boiler blowdown controller LRR 1-10.

#### Technical Data

##### Max. service pressure

10 bar at saturated steam temperature 183 °C  
(= 145 psig at 361 °F)

##### Connection

½" BSP, DIN ISO 228

##### Length of installation

24 mm

##### Materials

Measuring sensor: Stainless steel  
X10CrNiS189  
(DIN No. 1.4305)

Measuring chamber: Stainless steel  
X5CrNi189  
(DIN No. 1.4301)  
Insulating sleeve: PEEK

##### Minimum conductivity

2 µS/cm at 25 °C (77 °F)

##### Max. permissible ambient temperature at terminal box

70 °C (158 °F)

##### Electrical connection

Four-pole connector with screw terminals, cable strain relief and cable gland Pg 11

##### Cell constant of electrode

C = 1 cm<sup>1</sup>

##### Protection

IP 65

##### Weight

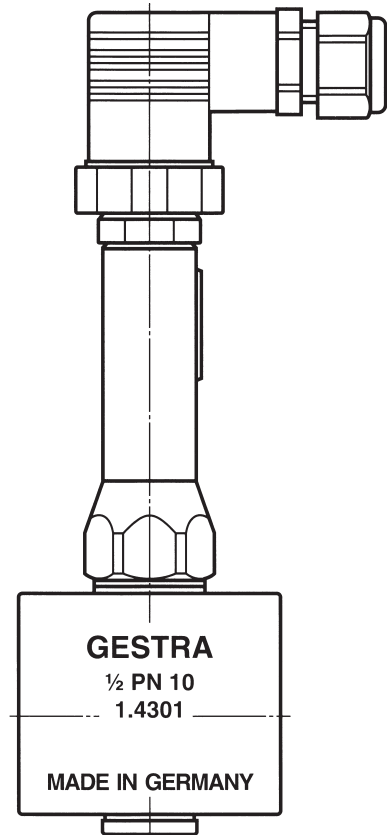
1.0 kg

#### Important Notes

Cable required for wiring: Screened four-core cable, e.g. 2 x 2 x 0.8 or 4 x 0.5 mm<sup>2</sup>.

Maximum length 100 m.

Maximum length 15 m when used with ancillary unit URN 1 (24 V DC).



## Conductivity Electrode Type LRG 12-2

### Order and Enquiry Specifications

GESTRA Continuous blowdown control

Conductivity electrode type LRG 12-2

Acceptance Inspection .....

Length of installation 24 mm

The following test certification can be issued on request, at extra cost: In accordance with DIN 50049-2.1, -2.2 and -3.1B.

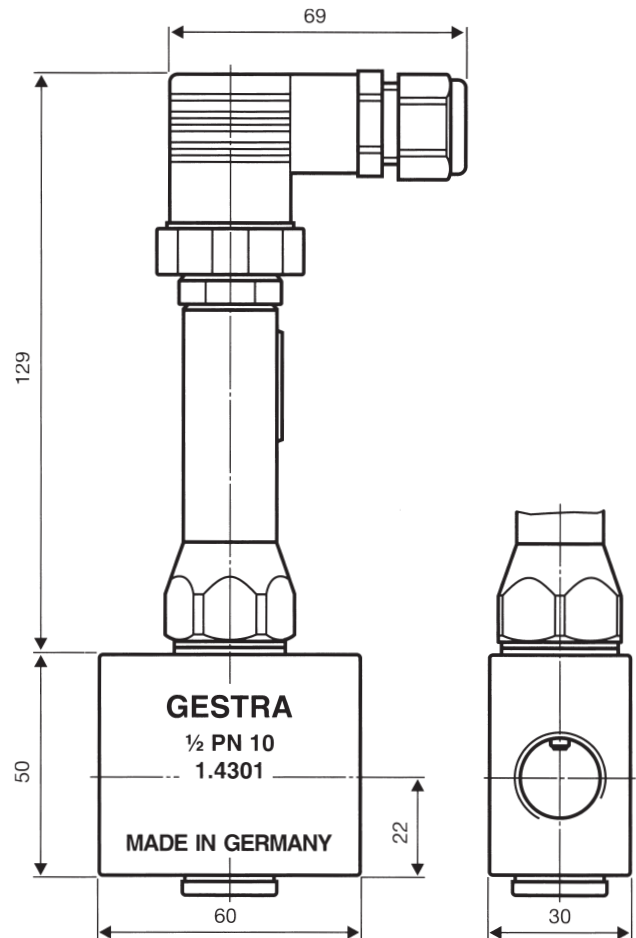
All inspection requirements have to be stated with the order. After supply of the equipment certification cannot be established. For tests and inspection charges please consult us.

### Associated Controller

Boiler blowdown controller LRR 1-10

### Associated Equipment

Continuous blowdown ball valve type 510 or continuous blowdown valve REAKTOMAT® type BAE 36.



Supply in accordance with our general terms of business.

## Flowserve GESTRA U.S.

2341 Ampere Drive  
Louisville, KY 40299  
Tel.: 001502 / 2672205, 001502 / 2672206  
Fax: 001502 / 2665397  
Email: dgoodwin@flowserve.com



GESTRA



## GESTRA Steam Systems

Product Range B1

### Conductivity Electrode LRG 12-1

### LRG 12-1

#### Purpose and Application

Continuous monitoring of the conductivity of liquids, signalling of limit values, remote indication or recording with the GESTRA conductivity transmitter type LRT 1.

Application in steam boiler plants for feedwater and condensate monitoring, as well as in district heating plants, paper and woodworking industries, catering kitchens, for dyebath monitoring in dye works, for conductivity monitoring in water treatment plants.

#### Design

The conductivity electrode is provided with two electrode tips completely insulated by a PTFE tubing with the exception of the free ends. The non-insulated ends form together with a PTFE sleeve a measuring cell. The screwed body incorporates a temperature feeler. A system of compression springs ensures a pressure-tight sealing between electrode tips and body even at varying temperatures.

The conductivity electrode type LRG 12-1 is supplied with a screwed connection 1 1/4" BSP, PN 10 (1 1/4" NPT on request). Installation inside the boiler.

#### Operation

For monitoring the liquid, its conductivity is used. The conductivity produces a proportional current if measuring surface and voltage supply remain constant.

Modifications in conductivity owing to temperature changes are compensated by the temperature feeler.

#### Technical Data

##### Max. service pressure

10 barg (145 psig)

##### Max. service temperature

184 °C

##### Connection

PN 10, screwed 1 1/4" BSP (DIN 228)  
(Screwed 1 1/4" NPT on request)

##### Materials

Body: X6CrNiMoTi17-12-2 (DIN No. 1.4571)  
Electrode tips: 1.4571  
Insulating tubing: PTFE  
Sleeve: PTFE  
Terminal box: Plastics

##### Cell constant of electrode

C = 1.0 [1/cm]

##### Max. permissible ambient temperature at terminal box

60 °C

##### Electric connection

Four-pole connector with screw terminals, cable strain relief and cable gland Pg 11

##### Approx. weight

1 kg

#### Important Notes

Cable required for wiring: Screened cable, e.g. 6 x 0.8 mm<sup>2</sup> for wiring to the LRT 1-5b, 4 x 0.8 mm<sup>2</sup> for wiring to the LRT 1-6b, max. cable length see data sheet LRT 1-...

The conductivity electrode may be installed vertically or horizontally. The open end (measuring cell) must be constantly submerged.

For fluid temperatures above 120 °C horizontal installation is recommended to ensure that the max. permissible temperature of 60 °C at the terminal box is not exceeded.

#### Order and Enquiry Specifications

GESTRA conductivity electrode used as sensor for conductivity monitoring:

Conductivity electrode type LRG 12-1, PN 10, with screwed connection 1 1/4" BSP, DIN 228 (1 1/4" NPT on request).

#### The following test certificates can be issued on request, at extra cost:

In accordance with EN 10204-2.1, -2.2 and -3.1B.

All inspection requirements have to be stated with the order. After supply of the equipment certification cannot be established. For tests and inspection charge please consult us.

#### Associated Equipment

Conductivity transmitter type LRT 1-5b or LRT 1-6b as measuring transducer with current output 0 to 20 mA or 4 to 20 mA.



Conductivity electrode LRG 12-1

# Conductivity Electrode LRG 12-1

## Installation and Service Instructions

Handle conductivity electrode with care.

### Installation

Screw electrode with ring joint supplied and/or Teflon tape into vessel and tighten.

It is absolutely necessary that the measuring cell protrudes from the screwed socket **by at least 10 mm** (see figure opposite).

### Note

The electrode body situated above the hexagonal part must not be insulated.

### Wiring

Always use screened cable for wiring. Connect screen only to corresponding terminal of the electronic unit connected to the electrode in accordance with respective wiring diagram. Do not connect screen to earth terminal of electrode.

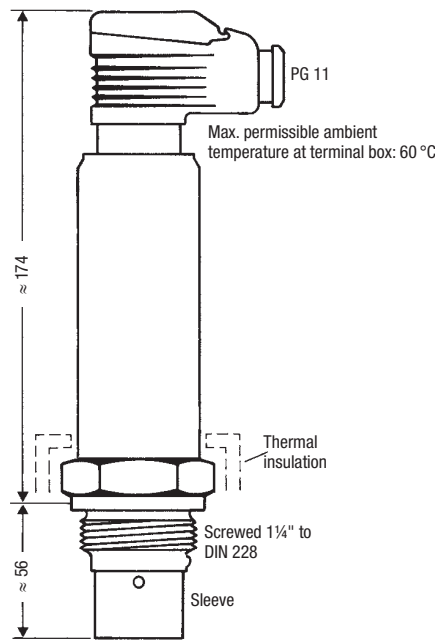
When several electrodes are fitted in a steam boiler or vessel, the electrode body and the terminal box should be marked to avoid confusion.

### Maintenance

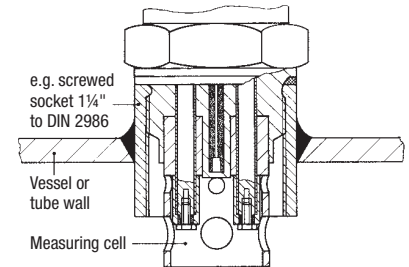
The electrode does not require any particular maintenance. It is, however, recommended to check the electrode tips from time to time as they must stay free from deposits. To clean electrode tips rinse measuring cell with trichloroethylene or similar or with 10 % hydrochloric acid.

Supply in accordance with our general terms of business.

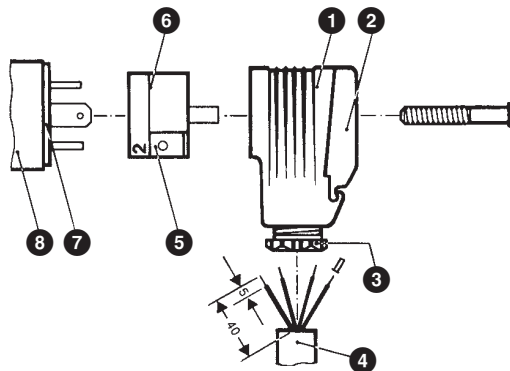
## Dimensions



Conductivity electrode type LRG 12-1

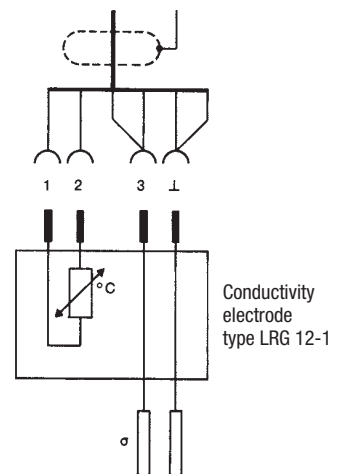


Installation of conductivity electrode in a screwed socket



- 1 Terminal box housing
- 2 Cap
- 3 Cable gland Pg 11 with internal cable strain relief for circular cables 6 – 10 mm diameter
- 4 Connecting cable
- 5 Terminal block with terminals
- 6 Strip with terminal marking points
- 7 Flat joint gasket
- 8 Plug on electrode head

Terminal box with item numbers and marking points



Wiring in the terminal box

## Flowserve GESTRA U.S.

2341 Ampere Drive  
Louisville, KY 40299  
Tel.: 001502 / 2672205, 001502 / 2672206  
Fax: 001502 / 2665397  
Email: dgoodwin@flowserve.com



GESTRA

## GESTRA Steam Systems

### Conductivity Transmitters LRT 1-5b, LRT 1-6b

Product Range B1

### LRT 1-5b LRT 1-6b

#### Purpose and Application

Measuring transducer with analogue current output for continuous monitoring of the conductivity of liquids, signalling of limit values, remote indication or recording with the GESTRA conductivity electrode type LRG 12.

Application mainly in condensate systems to detect any pollution by foreign matter, for example in steam boiler plants for monitoring the boiler water or the condensate returned to the boiler.

#### Design

Plug-in unit in plastic case for installation in control cabinets. The terminals in the case are accessible after loosening two screws and unplugging the unit from its base. To avoid confusion with other plug-in units of the GESTRA range, inserts are fitted in the bases so that only the correct unit may be plugged into each base.

The plug-in units may be snapped onto a 35 mm supporting rail or screwed into position on a mounting panel.

Field enclosures for several plug-in units are available on request.

#### Technical Data

##### Function

Measuring transducer with analogue current output for conductivity with conductivity electrode type LRG 12-1, automatic temperature compensation within the range 25 ... 180 °C

##### Input

4 connections for the conductivity electrode type LRG 12-1.

##### Output

Current output 0 ... 20 mA or 4 ... 20 mA by an external wire link, max. load 500 Ω, galvanically separated from probe measuring circuit; residual ripple of output current 50 μA<sub>p</sub>

##### Measuring ranges

LRT 1-5b: 0 ... 10 mS/cm, 0 ... 1 mS/cm

LRT 1-6b: 0 ... 100 μS/cm, 0 ... 10 μS/cm

(selection between the 2 ranges by switch on front panel, values referred to 25 °C)

##### Temperature compensation

Continuously adjustable within the range 0 ... 4 % / °C

##### Compensation range

25 – 180 °C

##### Temperature measurement

by integral NTC feeler

##### Cell constant of conductivity electrode

C = 1.0 [1/cm]

##### Indicator

1 meter, 45 x 45 mm, scale 0 ... 100 %

##### Electrode supply voltage

Delta voltage 0.5 V<sub>p</sub>/1000 Hz

##### Mains supply

24 V, 110 V, 120 V, 230 V, 240 V, 50 ... 100 Hz, 3.5 VA (please state voltage when ordering), 24 VDC supply also possible with the ancillary unit type URN-1

##### Protection

IP 40

#### Permissible ambient temperature

0 ... 50 °C

#### Case materials

Base: ABS plastic, black

Cover: polystyrene (highly shock-resistant), stone grey

#### Approx. weight

0.5 kg

#### Import Notes

Cable required for wiring to the electrode: Screened cable, e.g. 6 x 0.8 mm<sup>2</sup> for LRT 1-5b, 4 x 0.8 mm<sup>2</sup> for LRT 1-6b, cable length see table under "Installation and Service Instructions".

#### Order and Enquiry Specifications

GESTRA conductivity transmitter as measuring transducer with current output used with the GESTRA conductivity electrode type LRG 12-1:

Conductivity transmitter type LRT 1-..., plug-in unit in plastic case for installation in control cabinets

Mains supply ..... V

#### Associated Equipment

Max.-min. limit switch type URS 2b for MAX and MIN alarms

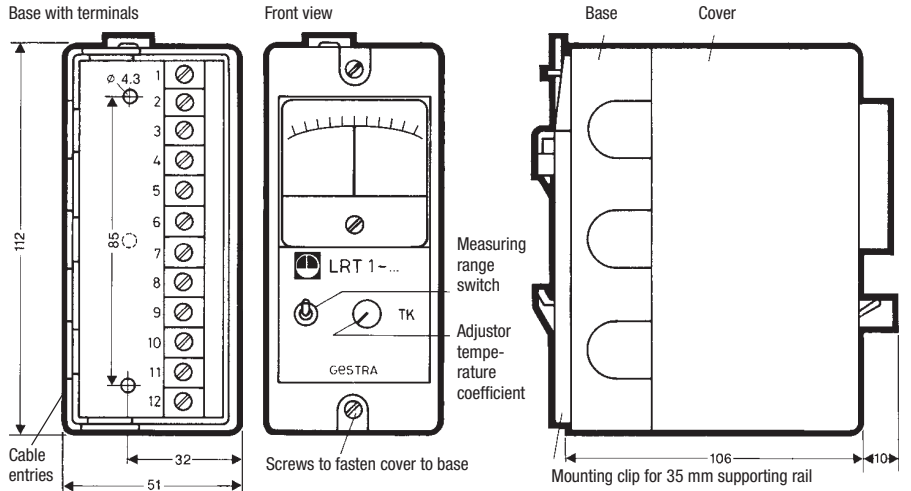
Level indicator type ARZ 4 with LED analogue display



Conductivity transmitter LRT 1-5b

# Conductivity Transmitters LRT 1-5b, LRT 1-6b

## Dimensions

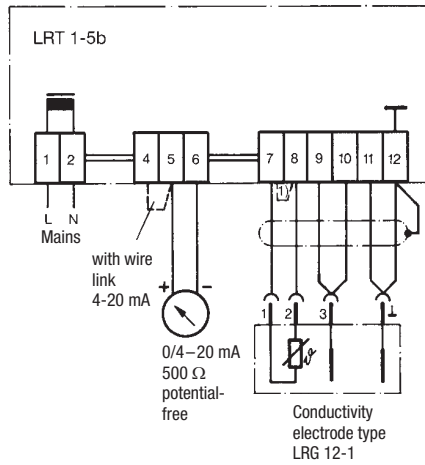


⊙ holes to be drilled to 4.3 mm dia for installation of unit in boiler panel

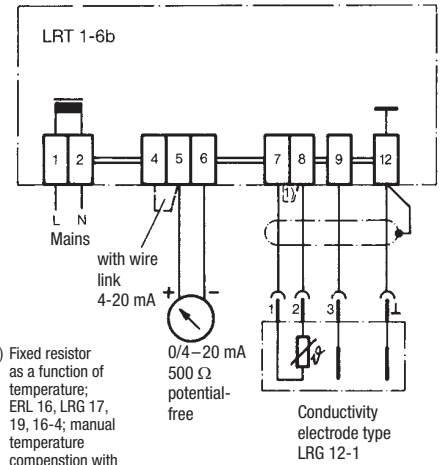
⊕ hole drilled for mounting clip

Dimensions of conductivity transmitter type LRT 1-5b, LRT 1-6b

## Wiring Diagrams



Conductivity transmitter type LRT 1-5b



Conductivity transmitter type LRT 1-6b

Supply in accordance with our general terms of business.

## Flowserve GESTRA U.S.

2341 Ampere Drive  
Louisville, KY 40299  
Tel.: 001502 / 2672205, 001502 / 2672206  
Fax: 001502 / 2665397  
Email: dgoodwin@flowserve.com



GESTRA

## GESTRA Steam Systems

Product Range B

Conductivity (TDS) Controller and Limiter /  
Intermittent Blowdown Cycling Timer

**LRR 1-40**

**LRR 1-40**  
**CAN-Bus**

### Description

The continuous blowdown controller LRR 1-40 used in conjunction with the conductivity sensing electrode LRG 16-40 constitutes a conductivity (TDS) monitoring and control system. Electrical conductivity is used to measure boiler water TDS (= Total Dissolved Solids). The blowdown controller features the following functions:

- Two conductivity limits with one switchpoint each: TDS high (MAX) alarm and TDS low (MIN) alarm. The TDS low (MIN) alarm can alternatively be used to control an intermittent blowdown valve.
- Three-position control within a predefined proportional band.
- TDS level (conductivity) monitored and maintained within a predefined control range.
- Stand-by input.
- 24 h purging pulse for continuous boiler blowdown.

The LRR 1-40 can, by choice, be provided with an actual value output with a standard signal of 4 - 20 mA. The TDS data are transferred to the controller or another system component via a CAN data bus. The controller and the conductivity sensing electrode use the CANopen protocol.

### Function

At regular intervals the conductivity sensing electrode LRG 16-40 sends a data signal to the blowdown controller LRR 1-40. The data transfer is effected by means of a CAN bus according to DIN ISO 11898 using the CANopen protocol. The transferred measuring data are evaluated and assigned to the control range and the switchpoints. A standard output signal of 4-20 mA (optional extra) is provided for external conductivity (TDS) indication. The control terminal and display unit URB 1 can be used to manually set a de-energizing time delay for the relay. To guarantee the correct and fail-safe operation of the system the data transmitting cycle is constantly monitored by the TDS controller. If the CAN bus line is interrupted, the TDS controller sends a visual signal to indicate a malfunction and the relays 1 and 4 will be instantaneously de-energized (fail-safe position).

The additional control terminal and display unit URB 1 permits a second water level indication and a continuous display of the actual TDS – i. e. conductivity – value in accordance with WÜL 00.

### Design

#### LRR 1-40b

Enclosure of insulating material with terminals for installation in control cabinets. The terminals are externally accessible. Clipping onto a 35 mm standardised supporting rail TS 35 x 15 to DIN EN 50022.

External dimensions: 100 x 73 x 118

### CAN Bus

All level and conductivity switches, controllers and electrodes are interconnected by means of a CAN bus. The data exchange is effected by means of a CAN bus according to DIN ISO 11898 using the CANopen protocol. Every item of equipment features an electronic address (Node ID). The four-core bus cable serves as power supply and data highway for high-speed data communication.

The LRR 1-40 is configured at our works and ready for service with other GESTRA components.

The LRR 1-40 can be used straight away without having to set the Node ID.

### Technical Data

#### Type approval

TÜV- WÜL-02-007

BAF-MUC 02 05 103881 003

#### Input

Interface for CAN bus to DIN ISO 11898, CANopen protocol. Feedback potentiometer 1000 Ω.

Voltage input 24 V – 230 V, 50 – 60 Hz for external command “Close valve” or “Control off” – stand-by –.

#### Output

Power supply 24 V DC, short-circuit protected.

Analogue output 4 - 20 mA, load 750 Ω for actual value indication (optional extra).

20 mA depending on range 20, 100, 200, 500, 1000, 2000, 6000, 12000 µS/cm.

Four volt-free relay contacts.

Max. contact rating with switching voltages of 24 V AC, 115 V AC and 230 V AC:

resistive 4 A, inductive 0.75 A at cos φ 0.5.

Max. contact rating at a switching voltage of 24 V DC: 4 A

Contact material: silver, hard-gold plated

#### Relay de-energizing delay

Output “MIN”, “MAX” 3 sec. (factory setting)

#### Indicators and adjustors

One red LED for switchpoint MAX (TDS HIGH)

One red LED for switchpoint MIN (TDS LOW) or for intermittent blowdown control.

Two green LEDs for deviations “X<sub>w</sub> MIN” and “X<sub>w</sub> MAX”.

One green LED “Power on”

One red LED “Bus malfunction”.

One ten-pole code switch “Node ID”, “Baud rate”,

Four push-buttons.

#### Setpoint

Setpoint W continuously adjustable within the whole control range between the adjusted MAX/MIN limits

#### Dead band

W < 2000 µS/cm = 3 %

W > 2000 µS/cm = 1 %

#### Switching hysteresis

1 – 25 % of setpoint W

#### Proportional band X<sub>p</sub>

1 – 150 % referred to W

0 % (factory setting)

#### Switching hystereses of MAX/MIN limits

MIN +1%, MAX -1%

#### 24 h purging pulse BAE

#### Automatic intermittent boiler blowdown

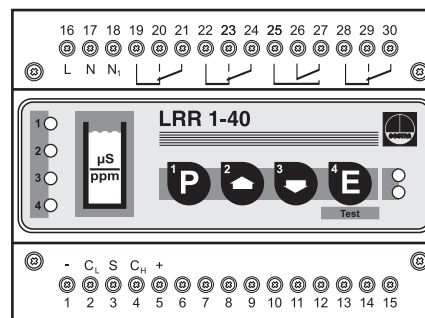
(MIN contact used for a timed output to control the purging intervals of bottom blowdowns)

Frequency: 1 – 120 h, in steps of 1 h in 1 sec.

Duration: 1 – 60 sec.

#### Control characteristic

Proportional controller for two- or three-position control



# Conductivity (TDS) Controller and Limiter / Intermittent Blowdown Cycling Timer LRR 1-40 CAN-Bus

## Technical Data – continued –

### Proportional band $X_p$

1 – 100 %

### Position feedback $X_r$

0 – 1000  $\Omega$

### Switching range (dead band) $X_{Sh}$

3 %

### Supply voltage

230 V +/- 10 %, 50/60 Hz

115 V +/- 10 %, 50/60 Hz (optional)

### Power consumption

5 VA

### Protection

Casing: IP 40 to DIN EN 60529

Terminal strip: IP 20 to DIN EN 60529

### Admissible ambient temperature

0 – 55 °C

### Enclosure material

Front panel: polycarbonate, grey

Casing: polycarbonate, black

### Approx. weight

0.8 kg

## Important Note

Note that multi-paired control cable, e. g. UNITRO-NIC® Bus Can 2 x 2 x ...mm<sup>2</sup> is required. Alternatively RE-2YCYV-fi 2 x 2 x ...mm<sup>2</sup> can also be used. Max. cable length 125 m at 250 kBit/s.

The bus **must** be wired in series. Star-type wiring (point-to-point) is **not** permitted.

Standard values for cable lengths between two bus-based devices (length of segment) and for conductor sizes as specified in ISO 11898:

Length of segment [m]	Number of pairs and conductor size [mm <sup>2</sup> ]
up to 300	2 x 2 x 0.34
300 to 600	2 x 2 x 0.5
600 to 1000	2 x 2 x 0.75

To protect the switching contacts provide circuit with a 2.5 A anti-surge fuse or – according to TRD regulations – with 1.0 A for 72 hrs operation.

## Order and Enquiry Specification

GESTRA TDS controller LRR 1-40 CANopen

Mains voltage ..... V

## Ancillary Unit

■ Conductivity sensing (TDS) electrode LRG 16-40 CANopen

■ URB 1 as easy-to-use control terminal and display unit for LRR 1-40 CANopen

Supply in accordance with our general terms of business.

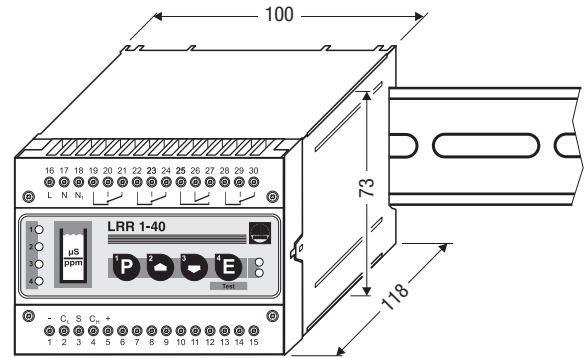
## Dimensions

MAX 55 °C

MAX 95 %

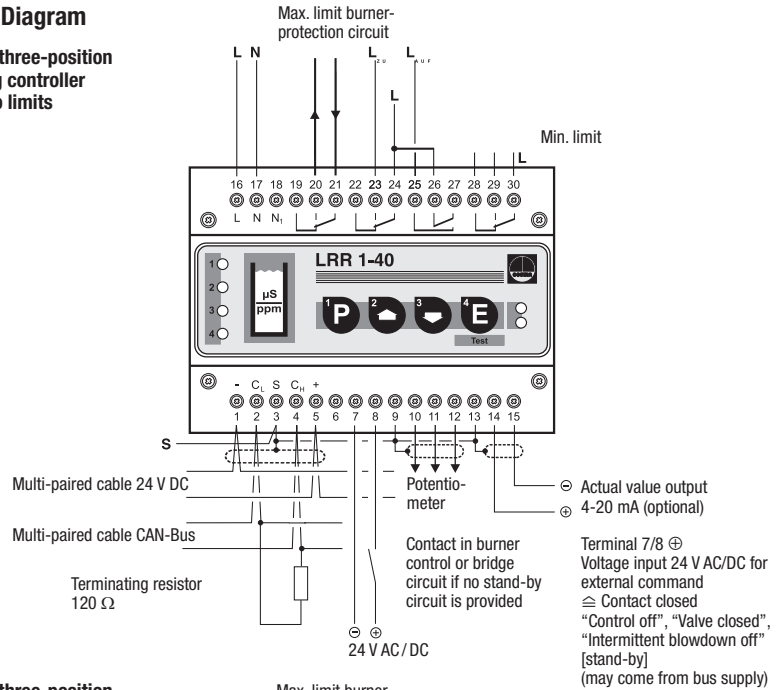
IP 20

CE

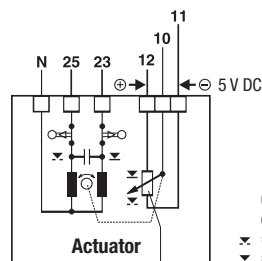
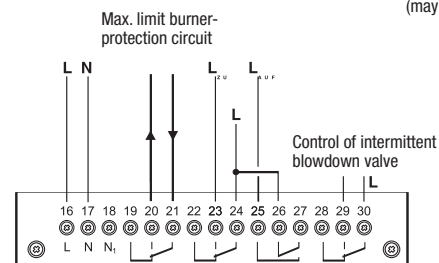


## Wiring Diagram

### Two- or three-position stepping controller with two limits



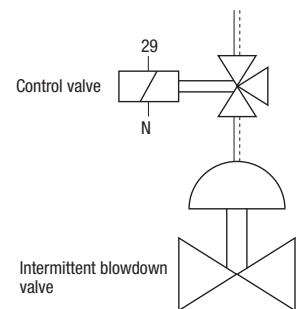
### Two- or three-position stepping controller with one limit value and intermittent blowdown function



Feedback potentiometer 1000  $\Omega$

### Continuous blowdown control

- ⊗ = Valve OPEN 25
- ⊙ = Valve CLOSED 23



# Flowserve GESTRA U.S.

2341 Ampere Drive  
Louisville, KY 40299  
Tel.: (502) 267-2205  
Fax: (502) 266-5397  
Email: fcd-gestra-usa@flowserve.com



GESTRA

## GESTRA Steam Systems

Product Range A4

Control Valve with Radial Stage Nozzle

**ZK 29**

**PN 160**

**DN 25, 50, 80, 100, 150 mm (1, 2, 3, 4, 6")**

**ZK 29**

### Description

Control valve for operation at high differential pressures.

Application, for example, in industrial plants and power stations as

- Injection-cooling valve
- Warm-up valve
- Drain valve
- Continuous blowdown valve
- Feedwater control valve
- Leak-off valve
- Steam control valve

The pressure drop is decreased in the radial stage nozzle in several stages, so that the flow velocity is reduced leading to a considerable reduction in wear and noise (sound level 80 dB (A)).

Straight-through valve with yoke, spindle with plug and radial stage nozzle. On request also available as angle valve.

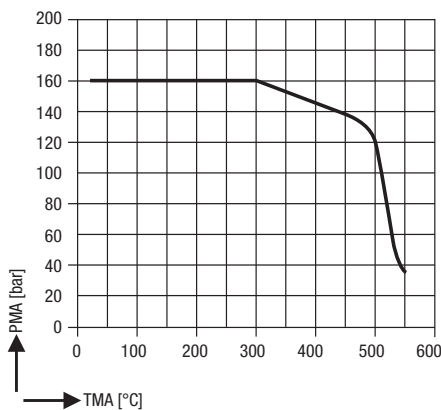
Internals (incl. seat) completely exchangeable. Leak rates in accordance with DIN 3230 BO 1.

#### Optional items:

- Inlet of sealing fluid
- Self-tightening stuffing box
- Adjustable lift limitation in the closing direction
- Sample valve

Pressure/Temperature Rating			
PMA (Maximum allowable pressure)	[barg] [psig]	160 2320	100 1450
TMA (Maximum allowable temperature)	[°C] [°F]	300 572	510 950
Δ PMX (Maximum differential pressure)	[bar] [psi]		100 1450

Differential pressure = inlet pressure minus outlet pressure



Materials	
Body DN 25, 50	forged alloy steel 13 CrMo 4 4 (DIN No.1.7335)
Body DN 80, 100, 150	cast steel GS-17 CrMo 5 5 (1.7357)
Spindle	stainless steel X 35 CrMo 17 (1.4122)
Valve plug and seat	stainless steel X 90 CrMoV 18, tempered (1.4112)

On request, at extra cost butt-weld ends of other materials and dimensions by welding of pipe ends.

The control valve is suited for the following actuators:

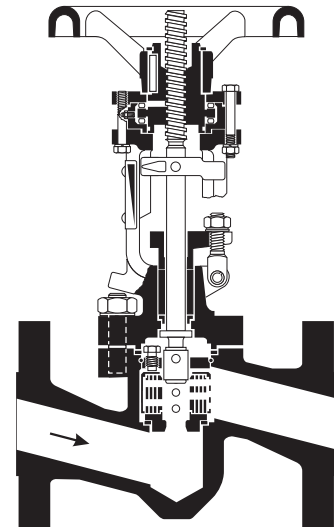
1. ZK 29/01  
Manual operation, not convertible (only DN 25–80)
2. ZK 29/13  
Electric linear actuator
3. ZK 29/14 (Standard)  
Design with insert bush for fitting an electric rotary actuator or a handwheel
4. ZK 29/20  
Pneumatic diaphragm actuator
5. ZK 29/30  
Lever without quarter-turn actuator fitted
6. ZK 29/31  
Lever for fitting a quarter-turn actuator

### Connections

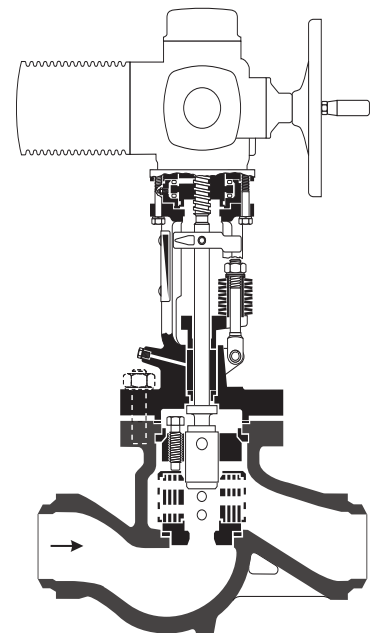
Butt-weld ends (Standard)

Flanges to DIN, PN 160 (BS 4504, table 160); on request flanges with dimensions to PN 40, 63 or 100, overall length, however Δ PN 160.

Special connections on request.

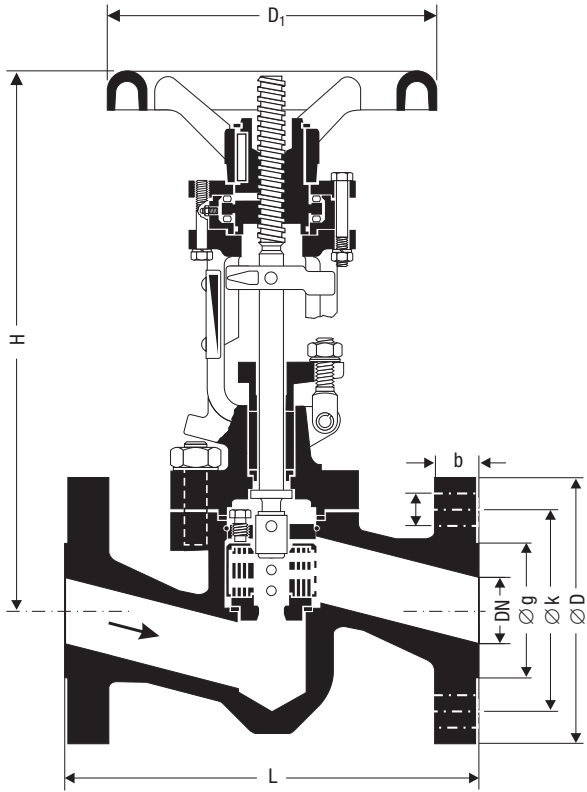


ZK 29/14, DN 25 mm (1")  
with flanged ends

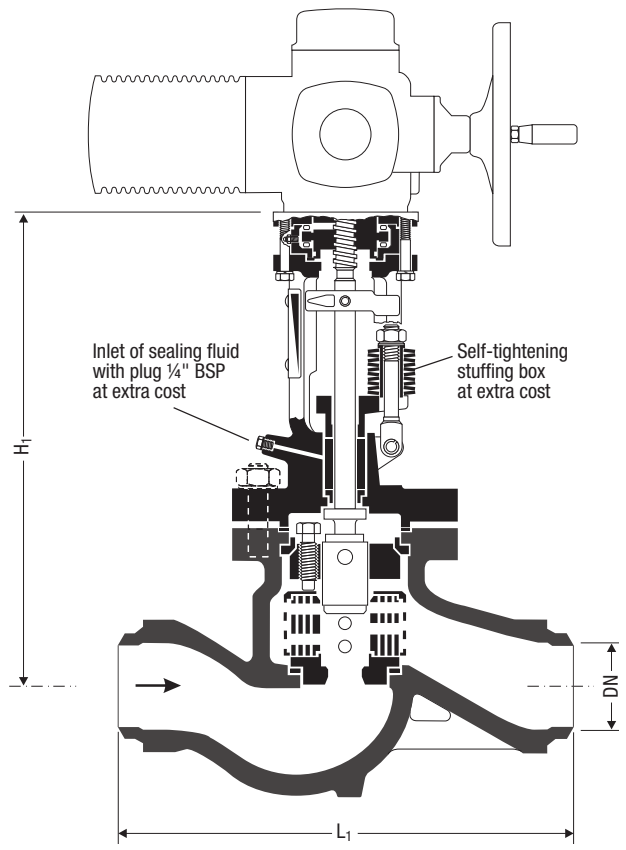


ZK 29/14, DN 80 mm (3")  
with butt-weld ends and lift restriction

**Dimensions**

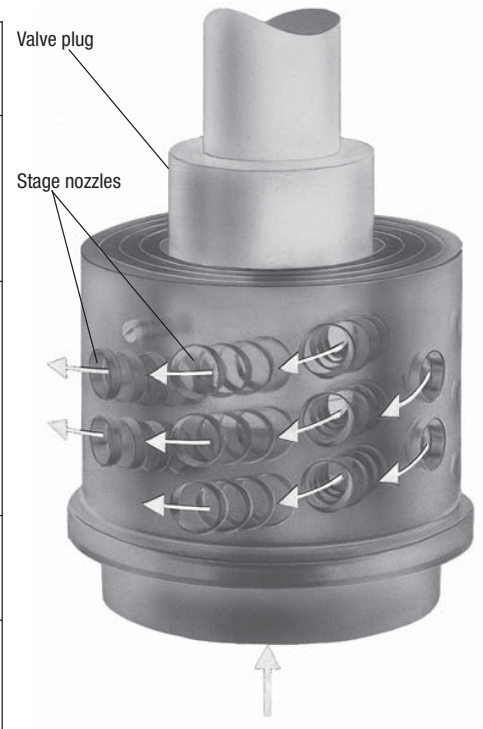


ZK 29/14, with handwheel  
DN 50 mm (2")



ZK 29/14, with electric rotary actuator  
DN 80 mm (3")

DN		[mm]	25	50	80	100	150
		[in]	1	2	3	4	6
Dimensions in mm	L		230	300	380	430	550
	H		325	390	480	630	740
	H <sub>1</sub>		270	320	405	540	660
	D <sub>1</sub>		125	200	200	320	500
Flange measurements in mm (PN 160)	D		140	195	230	265	355
	b		24	30	36	40	50
	k		100	145	180	210	290
	g		68	102	138	162	218
	l		18	26	26	30	33
Number of bolts			4	4	8	8	12
Butt-weld ends for pipe (DIN 3239-R4)			33.7x3.2	60.3x4	88.9x6.3	114.3x8	168.3x12.5
Approx. weight ZK 29/14	flanges	[kg]	16.5	33.5	63	120	215
	butt-weld ends	[kg]	12.5	25.5	50	100	180
	handwheel	[kg]	0.5	1.6	1.6	6	15



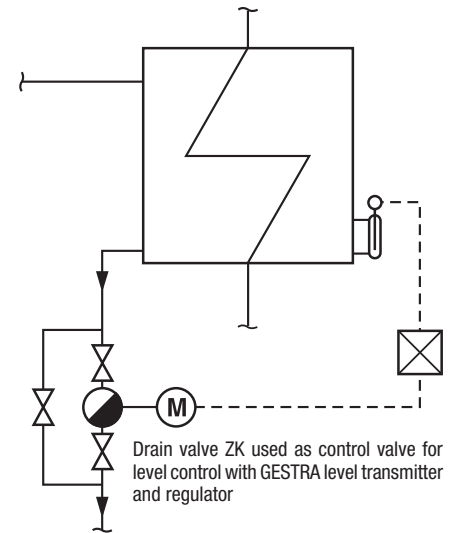
Radial stage nozzle as control unit



**k<sub>vs</sub> values**  
**Selection of Actuator**

DN	Characteristic	K <sub>vs</sub>			Valve stroke [mm]	Revolutions for full stroke of valve	Max. admis. torque for opening/closing [Nm]	Type/size of actuator DIN ISO 5210
		[m <sup>3</sup> /h]						
25 (1")	linear	0.7	1.4	2.1	16	4	20	B1-F10
25 (1")	equal-percentage	0.7	1.4	2.1	16	4	20	B1-F10
50 (2")	linear	3	6	9	33	8.3	60	B1-F10
50 (2")	equal-percentage	3	5.5	8	33	8.3	60	B1-F10
80 (3")	linear	14	21	28	45	11.3	60	B1-F10
80 (3")	equal-percentage	9	15	21	45	11.3	60	B1-F10
100 (4")	linear	20	33	46	60	12	95	B1-F10
100 (4")	equal-percentage	15	25	35	60	12	95	B1-F10
150 (6")	linear	70	100	130	90	15	215	B1-F14
150 (6")	equal-percentage	60	85	110	90	15	215	B1-F14

**Example of Application**



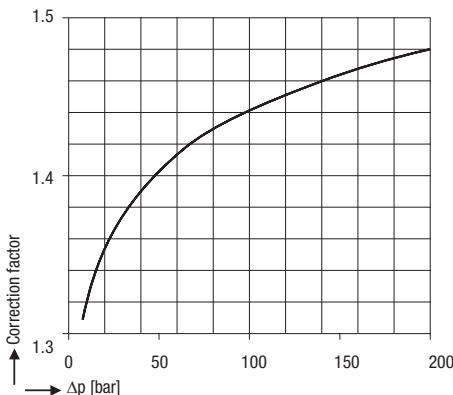
**Calculation of required k<sub>v</sub> value\***

- For water flowrates within temperature ranges where flashing because of pressure drop is not to be expected (e.g. leak-off and injection-cooling valves) the calculated k<sub>v</sub> value has to be multiplied by a correction factor taken from the chart below due to the successive expansion. The chart includes a safety factor of 1.2.
- If, due to the pressure drop, flashing is to be expected, the formulae below should not be used to calculate the k<sub>v</sub> value. In this case see overleaf for hot water capacity charts. If p<sub>2</sub>/p<sub>1</sub> > 0.5 multiply the chart reading by the correction factor K taken from the backpressure chart below. The safety factor of 1.2 must always be taken into consideration.
- For steam the calculated k<sub>v</sub> value has to be multiplied by a safety factor of 1.2.

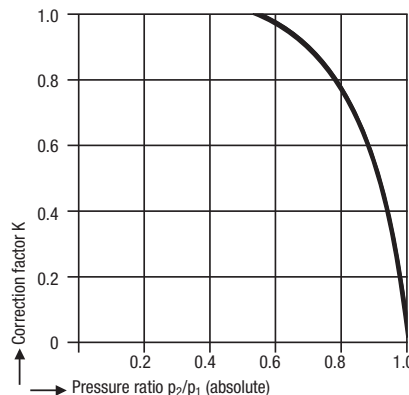
Pressure drop	k <sub>v</sub>	for liquids	for gas, temperature-corrected	for vapours	for saturated and wet steam
$\Delta p < \frac{p_1}{2}$ $(p_2 > \frac{p_1}{2})$	k <sub>v</sub>	$= \frac{\dot{V}}{31.6} \sqrt{\frac{\rho_1}{\Delta p}}$	$= \frac{\dot{V}_N}{514} \sqrt{\frac{\rho_N \cdot T_1}{\Delta p \cdot p_2}}$	$= \frac{\dot{m}}{31.6} \sqrt{\frac{v}{\Delta p}}$	$= \frac{\dot{m}}{31.6} \sqrt{\frac{v \cdot x}{\Delta p}}$
$\Delta p > \frac{p_1}{2}$ $(p_2 < \frac{p_1}{2})$	k <sub>v</sub>	$= \frac{\dot{m}}{31.6 \sqrt{\rho_1 \cdot \Delta p}}$	$= \frac{2 \dot{V}_N}{514 \cdot \rho_1} \sqrt{\rho_N \cdot T_1}$	$= \frac{\dot{m}}{31.6} \sqrt{\frac{2v}{\rho_1}}$	$= \frac{\dot{m}}{31.6} \sqrt{\frac{v \cdot x \cdot 2}{\rho_1}}$

\*) **Conversion Factors:** C<sub>v</sub> (U.S.) = 1.17 · k<sub>v</sub>  
C<sub>v</sub> (U.K.) = 0.98 · k<sub>v</sub>

**Correction factor for water flowrates (without flashing)**



**Back pressure chart**



**Nomenclature:**

- k<sub>v</sub> Valve flow coefficient for fully open valve within control range [m<sup>3</sup>/h]
- $\dot{V}$  Flowrate [m<sup>3</sup>/h]
- $\dot{m}$  Flowrate [kg/h]
- $\dot{V}_N$  Volume flowrate for gases at standard state (0 °C, 1013 mbar) [m<sup>3</sup>/h]
- p<sub>1</sub> upstream pressure [bar a]
- p<sub>2</sub> downstream pressure [bar a]
- Δp pressure drop p<sub>1</sub> - p<sub>2</sub> [bar]
- ρ<sub>1</sub> density of fluid with operating condition at T<sub>1</sub> and p<sub>2</sub> [kg/m<sup>3</sup>]
- ρ<sub>N</sub> density of gases at standard state (0 °C, 1013 mbar) [kg/m<sup>3</sup>]
- v specific steam volume at T<sub>1</sub> and p<sub>2</sub> or - if Δp >  $\frac{p_1}{2}$  - at  $\frac{p_1}{2}$  [m<sup>3</sup>/kg]
- T<sub>1</sub> absolute inlet temperature of fluid [K]
- x Content of dry saturated steam in wet steam (0 < x < 1)

**Control Valve with Radial Stage Nozzle  
ZK 29  
PN 160  
DN 25, 50, 80, 100, 150 mm  
(1, 2, 3, 4, 6")**

**Capacity Charts**

The charts indicate the maximum capacities of hot and cold water (condensate) the valve can discharge in continuous operation with the spindle in the utmost control position and linear characteristic.

Within their control range the valves (in all sizes) have a linear characteristic. For special operating conditions the adjustment of the radial stage nozzle can be modified to obtain different  $k_{vs}$  values and consequently flowrates varying from those indicated in the charts opposite. The linear characteristic is, however, maintained.

It is also possible to change the lift-flowrate characteristic from linear to equal-percentage by repositioning nozzle rings.

**Order and Enquiry Specifications**

GESTRA Control valve with radial stage nozzle ZK 29

Design data:  $p = \dots \text{ bar}$   $t = \dots ^\circ\text{C}$

Operational data: Load Conditions

	1	2	3
$p_1$ [bar]			
$t_1$ [ $^\circ\text{C}$ ]			
$p_2$ [bar]			
$\Delta p$ [bar]			
$\dot{m}$ [t/h]			

(Please enter data)

Fluid: .....

Actuators: Electric (make)  
on-off or modulating control  
Voltage/Hz  
Control voltage/Hz

Pneumatic (make)  
Spring to open   
Spring to close   
Handwheel yes/no  
Positioner yes/no

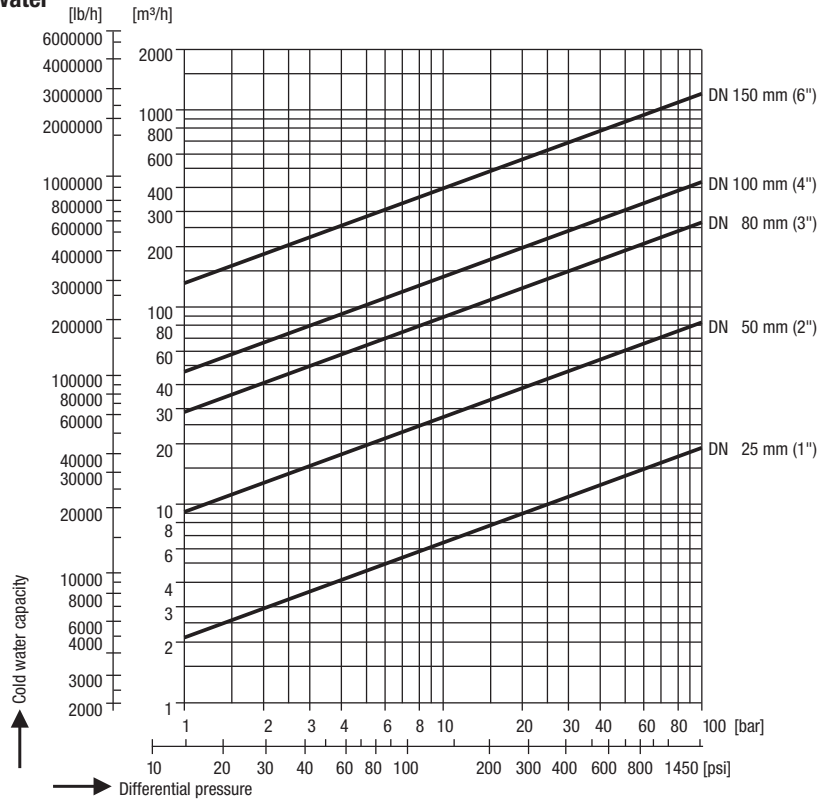
The following test certificates can be issued on request, at extra cost:

In accordance with EN 10204-2.1, -2.2, -3.1A, -3.1B and -3.1C.

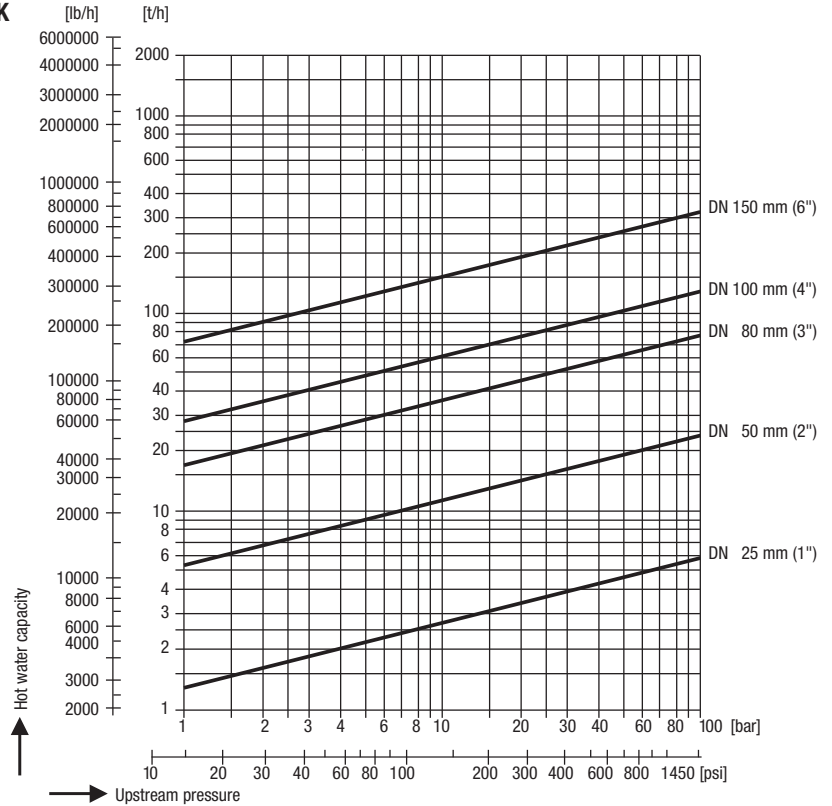
All inspection requirements have to be stated with the order. After supply of the equipment certificates can no longer be established. Charges and extent of the above mentioned certificates as well as the different tests confirmed therein are listed in our leaflet "Test and Inspection Charges for Standard Equipment". For other tests and inspections than those listed above, please consult us.

Supply in accordance with our general terms of business.

**Cold water**



**Hot water  
 $t_s - 5 \text{ K}$**



**Flowserve GESTRA U.S.**

2341 Ampere Drive  
Louisville, KY 40299  
Tel.: 001502 / 2672205, 001502 / 2672206  
Fax: 001502 / 2665397  
Email: dgoodwin@flowserve.com



GESTRA

## GESTRA Steam Systems

Product Range A4

Control Valve with Radial Stage Nozzle ZK and Tandem Shut-off

**ZK 313 ASME B 16.34**

**1" – 3", Class 2500**

**ZK 313 ASME**

### Description

Control valve for operation at high differential pressures. Application in industrial plants and power stations as

- Injection-cooling valve
- Warm-up valve
- Drain valve
- Continuous blowdown valve
- Feedwater control valve
- Leak-off valve
- Steam control valve

The pressure drop is decreased in the radial stage nozzle in several steps in order to reduce the flow velocity, thus leading to a considerable reduction in wear and noise (sound level  $\leq 85$  dB(A)).

### Design

All pressure parts of the ZK 313 are forged. Internals (incl. seat) are easily exchangeable, even after a long period of use.

The radial stage nozzle ZK combines the function of a control valve with a conventional shut-off valve and guarantees maximum wear protection and absolutely tight shut-off.

The valve body is available as straight-through or angle version (1" – 3").

The valve can be easily fitted with a pneumatic actuator.

ZK 313-.../20

D = Straight-through  
E = Angle

Leak rates in accordance with DIN 3230 B01. Tightness better than ANSI Class V.

### Differential pressure

- Δ PMX one stage 40 bar
- Δ PMX three stages 300 bar
- Δ PMX three stages with additional nozzle 370 bar

Materials			
<b>Body</b>	A 182 F1	1.7383 / A 182 F22	1.4903 / A 182 F91
<b>Upper body part</b>	1.4903 / A 182 F91		
<b>Bolts</b>	A 193 B16		
<b>Nuts</b>	A 194-7		

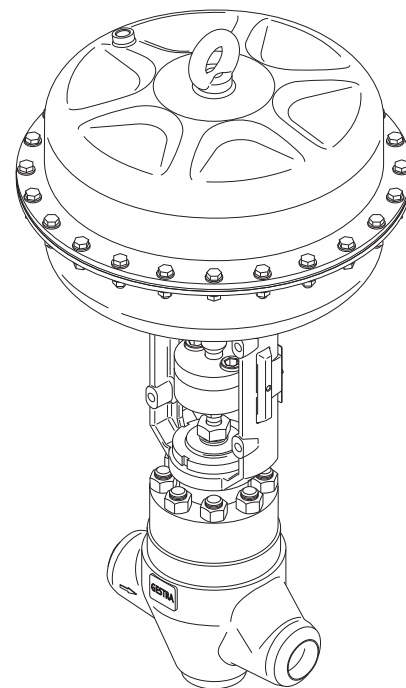
### End connections

Butt-weld ends, socket-weld ends

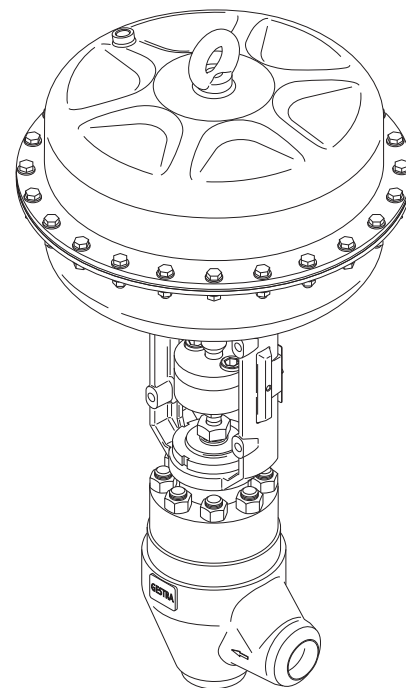
### Pressure / Temperature Ratings

Service Pressures for Class 2500 in [bar] to ASME B16.34						
Temperature in [°C]	Standard Class			Limited Class		
	Type F1	Type F22	Type F91	Type F1	Type F22	Type F91
20	398.9	430.9	430.9	398.9	430.9	430.9
100	388.4	429.4	429.4	398.9	430.3	430.9
200	368.1	406.5	406.5	398.9	416.9	430.9
300	350.2	357.1	357.1	398.9	413.7	430.9
400	304.9	304.9	304.9	398.9	396.0	418.3
450	281.8	281.8	281.8	390.8	372.0	393.1
500	196.4	231.7	235.0	255.6	303.9	303.9
515	149.6	204.7	219.6	195.6	268.2	279.1
520	137.5	192.6	217.3	181.8	255.3	277.3
530	113.3	168.4	212.6	154.0	229.6	273.6
535	101.2	157.1	210.6	140.1	216.9	272.1
550		127.9	208.0		179.2	270.7
560		110.2	207.3		154.4	270.7
570		94.4	201.5		132.2	266.2
580		81.0	189.5		113.4	256.2
590		67.6	177.4		94.7	246.2
595		62.5	169.9		87.6	236.9

Service Pressures for Class 2500 in [psig] to ASME B16.34						
Temperature in [°F]	Standard Class			Limited Class		
	Type F1	Type F22	Type F91	Type F1	Type F22	Type F91
68	5,784.1	6,248.1	6,248.1	5,784.1	6,248.1	6,248.1
212	5,631.8	6,226.3	6,226.3	5,784.1	6,239.4	6,248.1
392	5,337.5	5,894.3	5,894.3	5,784.1	6,045.1	6,248.1
572	5,077.9	5,178.0	5,178.0	5,784.1	5,998.7	6,248.1
752	4,421.1	4,421.1	4,421.1	5,784.1	5,742.0	6,065.4
842	4,086.1	4,086.1	4,086.1	5,666.6	5,394.0	5,700.0
932	2,847.8	3,359.7	3,407.5	3,706.2	4,406.6	4,406.6
959	2,169.2	2,968.2	3,184.2	2,836.2	3,888.9	4,047.0
968	1,993.8	2,792.7	3,150.9	2,636.1	3,701.9	4,020.9
986	1,642.9	2,441.8	3,082.7	2,233.0	3,329.2	3,967.2
995	1,467.4	2,278.0	3,053.7	2,031.5	3,145.1	3,945.5
1022		1,854.6	3,016.0		2,598.4	3,952.5
1040		1,597.9	3,005.9		2,238.8	3,952.2
1058		1,368.8	2,129.8		1,916.9	3,859.9
1076		1,174.5	2,747.8		1,644.3	3,714.9
1094		980.2	2,572.3		1,373.2	3,569.9
1103		906.3	2,463.6		1,270.2	3,435.1

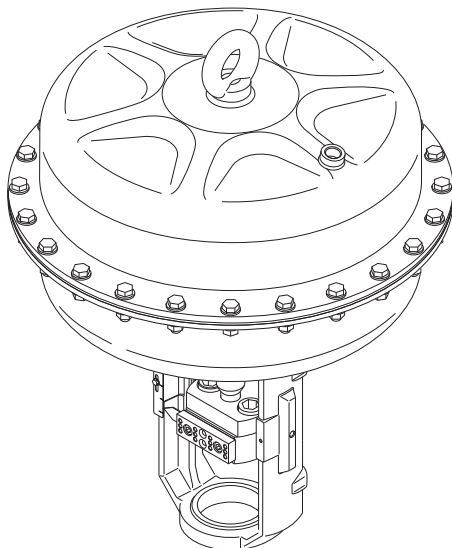
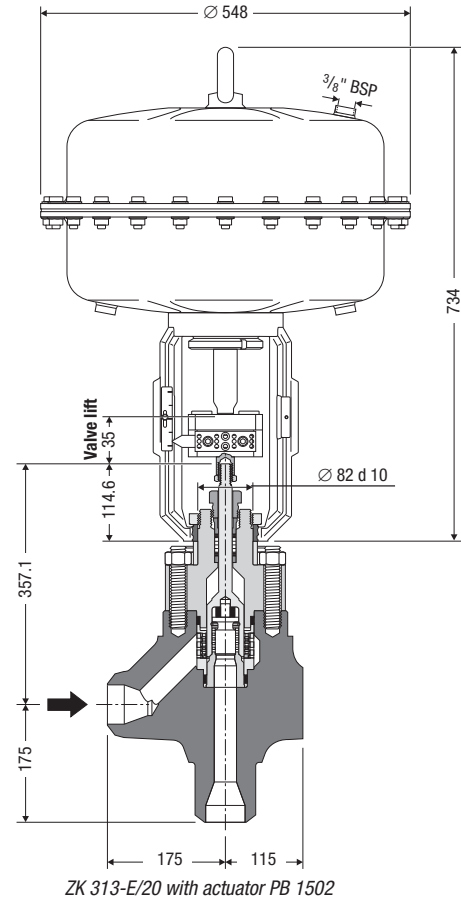
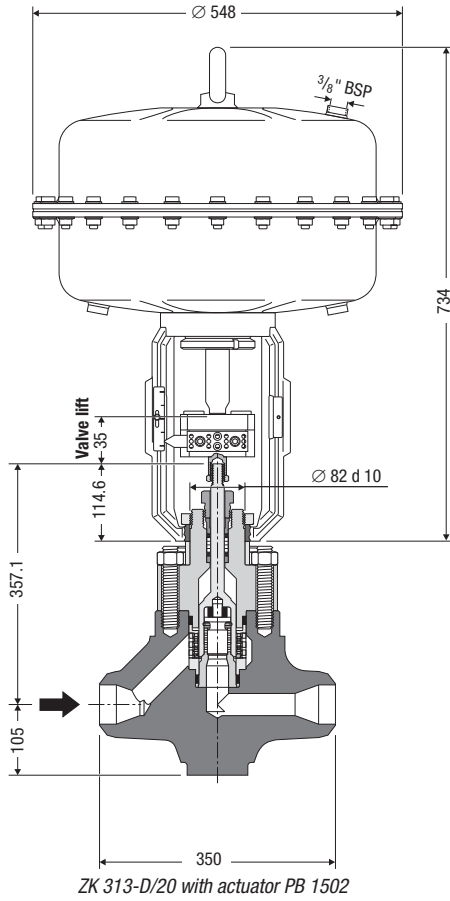


ZK 313-D/20

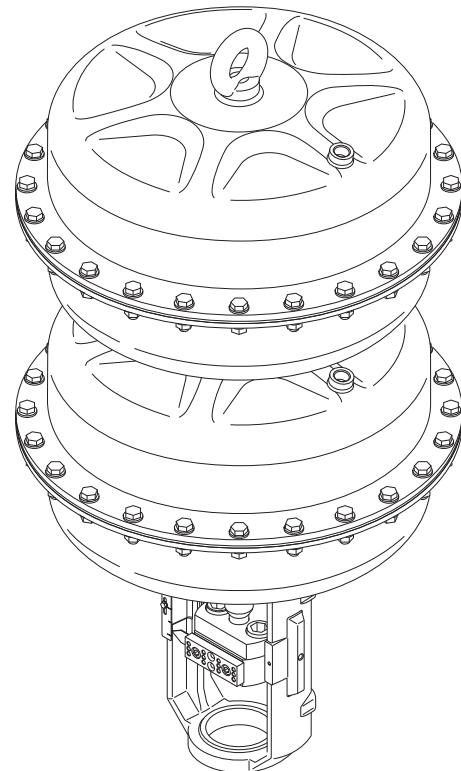


ZK 313-E/20

# Dimensions

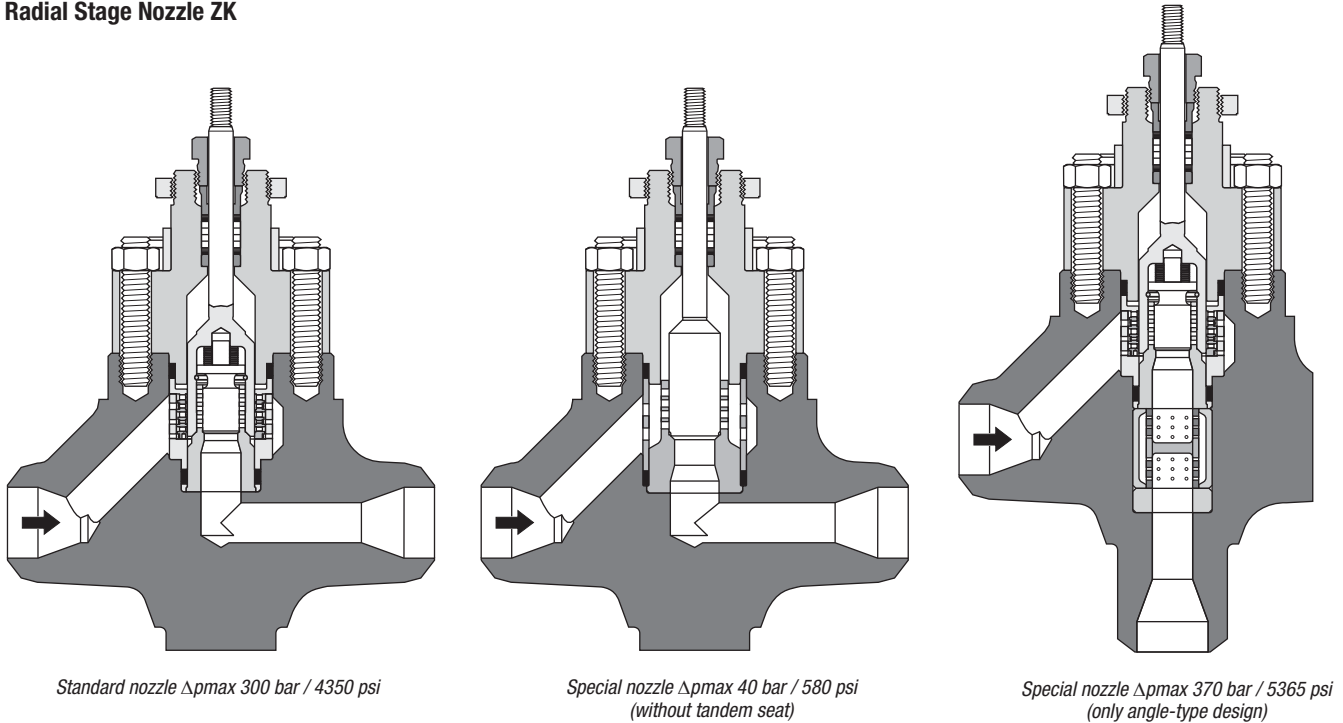


Actuator PB 1502  
1500 m<sup>2</sup>  
Supply air: max. 6 barg  
Actuating force up to 30 kN



Actuator PB 3002  
3000 m<sup>2</sup>  
Supply air: max. 6 barg  
Actuating force up to 60 kN

## Radial Stage Nozzle ZK



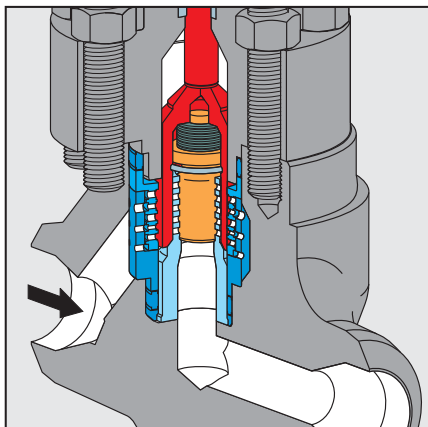
### kv<sub>s</sub> values

Size (DN)	Characteristic	$\Delta p$ max. [bar] [psi]	kv <sub>s</sub> (Cv)								Valve stroke [mm]
			1	1.5	2.3	3.6	5.5	8	11	13	
1" to 3"	linear/ equal-percentage	300 4350	1 (1.2)	1.5 (1.7)	2.3 (2.7)	3.6 (4.2)	5.5 (6.4)	8 (9.4)	11 (12.7)	13 (15)	35
1" to 3"	linear/ equal-percentage	370 5365					4.5 (5.3)	7 (8.2)	9.5 (11)	10.5 (12.1)	35
1" to 3"	linear	40 580	20 (23.1)								35

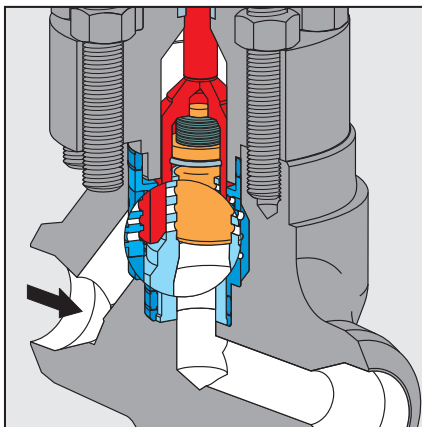
### Function of the tandem seat

At the beginning of the opening process the valve plug is lifted off the main seat but the valve cone follows only after a certain lift. As a consequence at the moment of

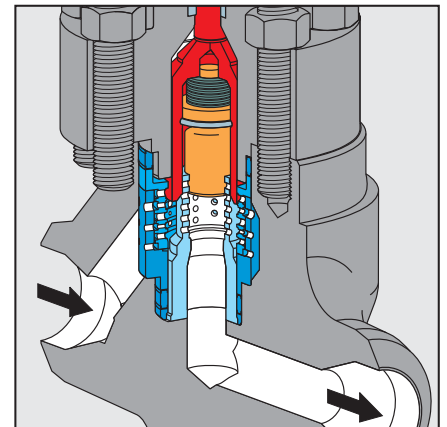
closing and at the beginning of opening the flow velocity at the valve seat is zero, which means that wire drawing is prevented.



Valve plug in closed position



Valve no longer in closed position but internal valve cone still closing



Valve plug in control position

**Control Valve with Radial Stage  
Nozzle ZK and Tandem Shut-off  
ZK 313 ASME B 16.34  
1" – 3", Class 2500**

**Capacity Charts**

The charts indicate the maximum capacities of hot and cold water for linear characteristics. A later modification from linear to equal-percentage is possible by exchanging the complete nozzle insert.

**Order and Enquiry Specification**

Control valve with radial stage nozzle  
ZK 313 ASME

Design data:  $p = \dots\dots\dots$  bar / psi     $t = \dots\dots\dots$  °C / °F

Operation: Load conditions (1–3)

	1	2	3
$p_1$ [bar] / [psi]			
$t_1$ [°C] / [°F]			
$p_2$ [bar] / [psi]			
$\Delta p$ [bar] / [psi]			
$\dot{m}$ [t/h] / [lb/h]			

Please enter data.

Fluid: .....

Actuator: pneumatic    Type .....

Spring to open   

Spring to close   

Handwheel    yes/no

Positioner    yes/no

$\Delta p_{max}$  for sizing of actuator ..... bar

Supply air ..... bar

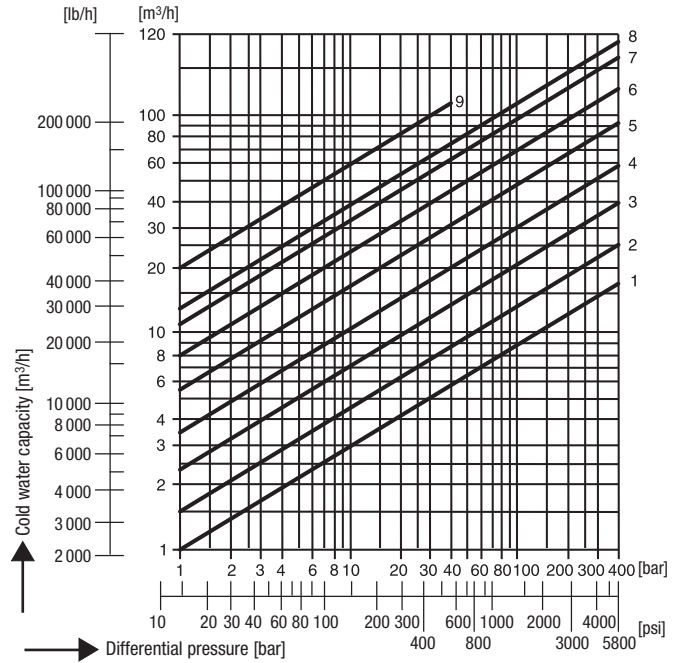
The following test certificates can be issued on request, at extra cost:  
In accordance with EN 10204/2.1, -2.2 and -3.1B.

All inspection requirements have to be stated with the order. After supply of the equipment certificates can no longer be established. Charges and extent of the above mentioned certificates as well as the different tests confirmed therein are listed in our leaflet "Test and Inspection Charges for Standard Equipment". For other tests and inspections than those listed above, please consult us.

Supply in accordance with our general terms of business.

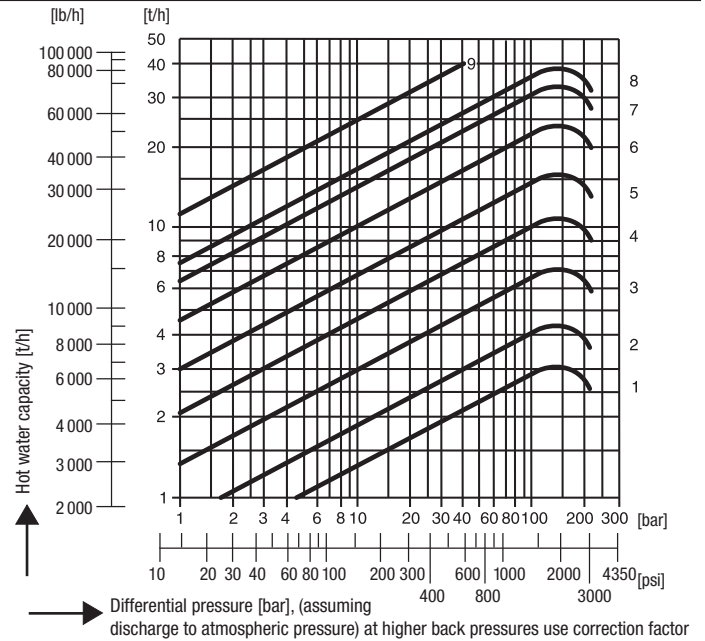
**Cold water**

Curve	$kvs$ value [m³/h]
1	1
2	1.5
3	2.3
4	3.6
5	5.5
6	8
7	11
8	13
9	20



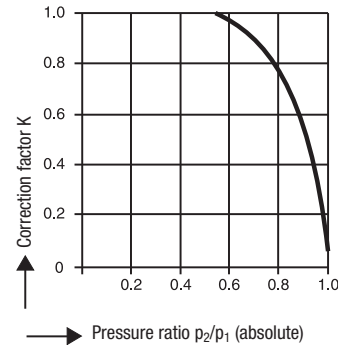
**Hot water  
ts-5 K**

Curve	$C_v$ -value [m³/h]
1	1.2
2	1.7
3	2.7
4	4.2
5	6.4
6	9.4
7	12.7
8	15.0
9	23.1



**Back-pressure chart**

With hot water the flowrate is reduced by the factor K.



**Flowserve GESTRA U.S.**

2341 Ampere Drive  
Louisville, KY 40299  
Tel.: (502) 267-2205  
Fax: (502) 266-5397  
Email: fcd-gestra-usa@flowserve.com



## GESTRA Steam Systems

Product Range A4

### Control Valve With Radial Stage Nozzle ZK and Tandem Shut-Off ZK 213 DN 80 – 250

ZK 213

#### Description

Control valve for operation at very high differential pressures.

Application, for example, in industrial plants and power stations as

- Leak-off valve for condensate pumps etc.
- Injection-cooling valve
- Start-up pot drain valve
- Feedwater control valve

The pressure drop is decreased in the radial stage nozzle ZK in several stages, so that the flow velocity is reduced leading to a considerable reduction in wear and noise (sound level  $\leq 85$  dB(A)).

The dual (tandem) shut-off combines the function of a conventional shut-off valve and a valve provided with regulating cone. At the beginning of the opening process first the main valve plug is lifted off the main seat, while the secondary valve plug remains closed until the main plug has reached a certain lift. At the moment of closing and at the beginning of opening the flow velocity at the valve seat is therefore zero so that wire drawing is excluded.

Angle-type or Z-type valve body.

The valve permits the use of several actuator types:

1. ZK 213-.../13  
Electric linear actuator
2. ZK 213-.../14  
Design with insert bush for fitting an electric rotary actuator or a handwheel
3. ZK 213-.../20  
Pneumatic diaphragm actuator
4. ZK 213-.../40  
Hydraulic linear actuator

**Example:** ZK 213-E2/14

E = angle version  
(Z = Z-type version)

2 = size  
see table "k<sub>vs</sub>-value"

14 = type of actuator  
(13, 14, 20, 40)

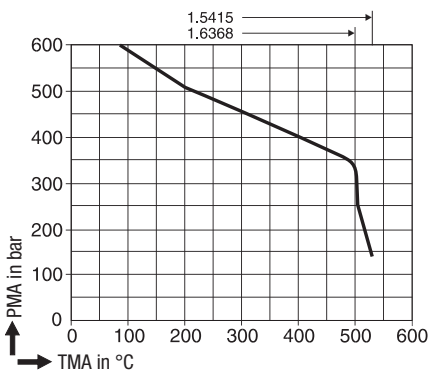
Internals completely exchangeable (incl. seat).

Leak rate acc. to DIN 3230 BN 1.

Pressure/Temperature Rating with materials			
1.5415		1.6368	
bar	°C	bar	°C
psig	°F	psig	°F
510	200	510	200
7400	392	7400	392
450	300	450	300
6530	572	6530	572
400	400	400	400
5800	752	5800	752
280	500	280	500
4060	932	4060	932
136	530		
1970	985		

Differential pressure

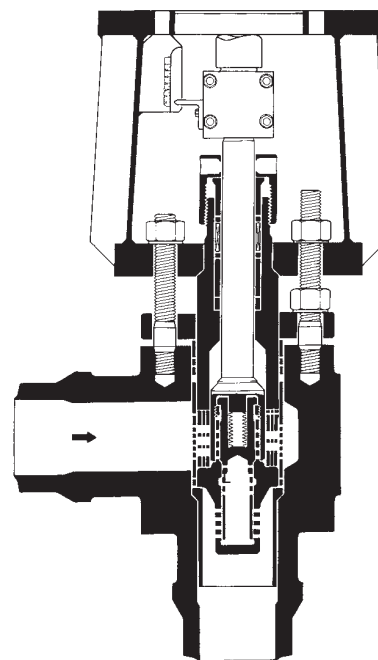
$\Delta PMX$  300 bar (4350 psi) – 4 stages  
560 bar (8120 psi) – 6 stages



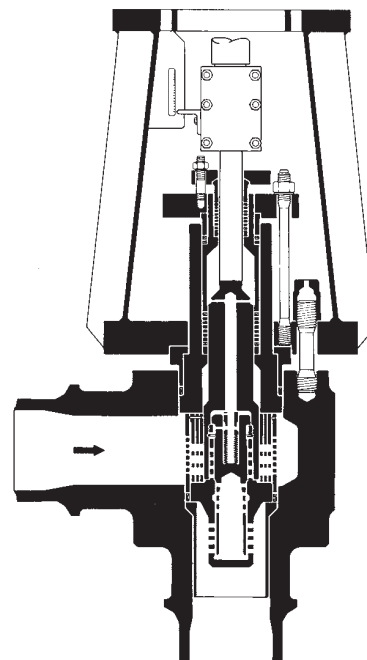
Materials	
Body	Forged alloy steel 15 Mo3 (1.5415) or WB 36 (1.6368)
Internals	s.s. X35CrMo 17 (1.4122) s.s. X90CrMoV 18 (1.4112) s.s. X20CrMoV 12 1 (1.4922)
Gland packing	Pure graphite

#### Connections

Butt-weld ends. Dimensions on request.

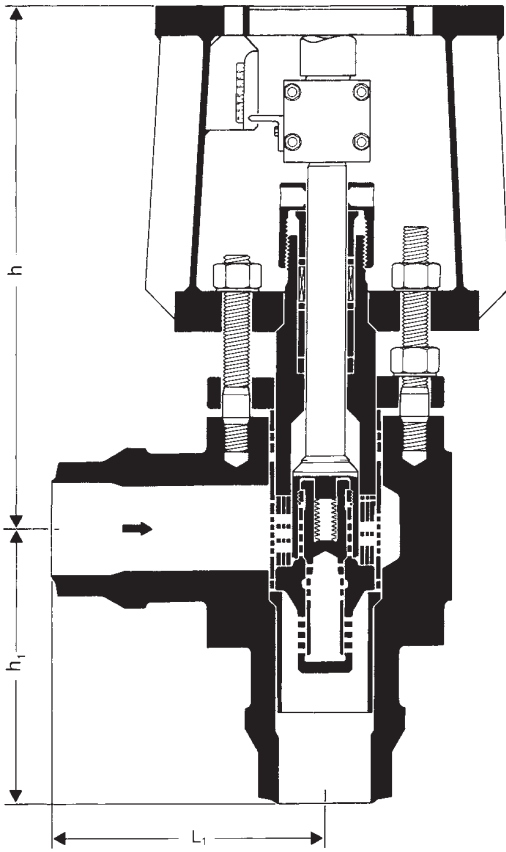


ZK 213  
Sizes 1 and 2

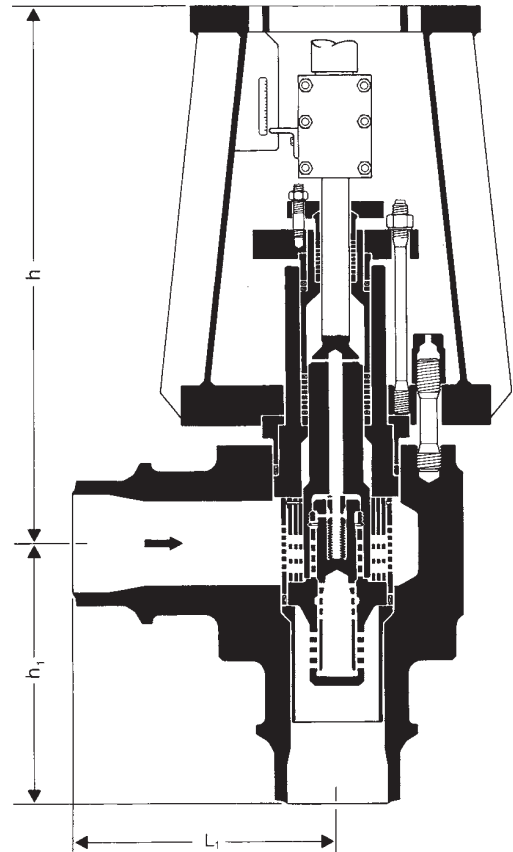


ZK 213  
Sizes 3 and 4,  
partially balanced

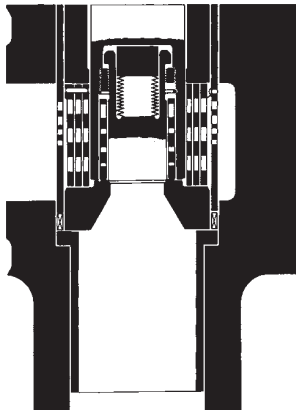
Dimensions



ZK 213-E.../...  
 Sizes 1 and 2  
 6 stages



ZK 213-E.../...  
 Sizes 3 and 4  
 6 stages,  
 partially balanced



ZK 213  
 4 stages

Size	1	2	3	4
DN mm (in)	180 (3) 100 (4) 125 (5)	100 (4) 125 (5) 150 (6)	125 (5) 150 (6) 200 (8)	150 200 250
h	635	735	890	910
h <sub>1</sub>	260	350	400	400
L <sub>1</sub>	260	350	400	400
Weight [kg]	210	370	540	600



### Calculation of required $k_v$ value\*)

- For water flowrates within temperature ranges where flashing because of pressure drop is not to be expected (e.g. leak-off and injection-cooling valves) the calculated  $k_v$  value has to be multiplied by a correction factor taken from the chart below due to the successive expansion. The chart includes a safety factor of 1.2.
- If, due to the pressure drop, flashing is to be expected, the formulae below should not be used to calculate the  $k_v$  value. In this case see overleaf for hot water capacity charts. If  $p_2/p_1 > 0.5$  multiply the chart reading by the correction factor K taken from the back pressure chart below. The safety factor of 1.2 must always be taken into consideration.
- For steam the calculated  $k_v$  value has to be multiplied by a safety factor of 1.2.

Pressure drop	$k_v$	for liquids	for gas, temperature-corrected	for vapours	for saturated and wet steam
$\Delta p < \frac{p_1}{2}$ $\left(p_2 > \frac{p_1}{2}\right)$	$k_v$	$= \frac{\dot{V}}{31.6} \sqrt{\frac{\rho_1}{\Delta p}}$	$= \frac{\dot{V}_N}{514} \sqrt{\frac{\rho_N \cdot T_1}{\Delta p \cdot \rho_2}}$	$= \frac{\dot{m}}{31.6} \sqrt{\frac{v}{\Delta p}}$	$= \frac{\dot{m}}{31.6} \sqrt{\frac{v \cdot x}{\Delta p}}$
$\Delta p > \frac{p_1}{2}$ $\left(p_2 < \frac{p_1}{2}\right)$	$k_v$	$= \frac{\dot{V}}{31.6} \sqrt{\frac{\rho_1}{\Delta p}}$	$= \frac{2 \dot{V}_N}{514 \cdot \rho_1} \sqrt{\rho_N \cdot T_1}$	$= \frac{\dot{m}}{31.6} \sqrt{\frac{2v}{\rho_1}}$	$= \frac{\dot{m}}{31.6} \sqrt{\frac{v \cdot x \cdot 2}{\rho_1}}$

\*) Conversion Factors:  $C_v$  (U.S.) = 1.17 ·  $k_v$      $C_v$  (U.K.) = 0.98 ·  $k_v$

#### Nomenclature:

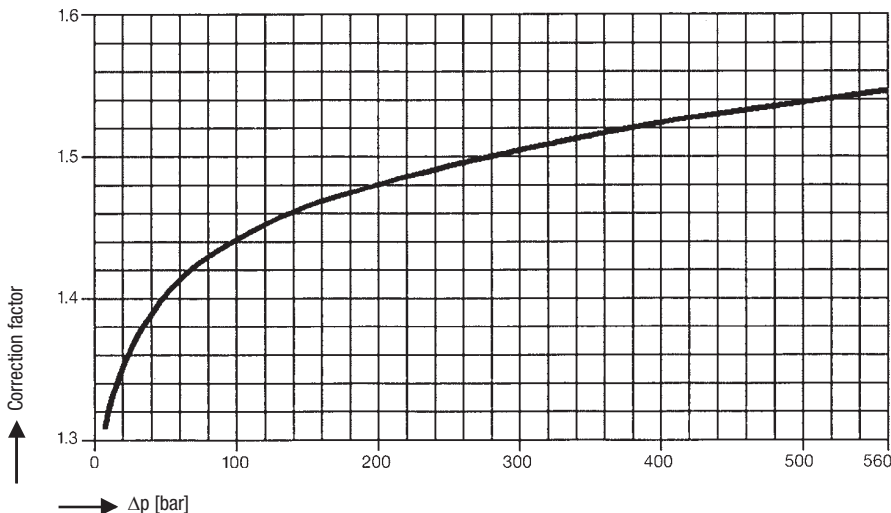
$k_v$	Value flow coefficient for fully open valve within control range	[m <sup>3</sup> /h]	$\rho_1$	Density of fluid with operating condition at $T_1$ and $p_2$	[kg/m <sup>3</sup> ]
$\dot{V}$	Flowrate	[m <sup>3</sup> /h]	$\rho_N$	Density of gases at standard state (0 °C, 1013 mbar)	[kg/m <sup>3</sup> ]
$\dot{m}$	Flowrate	[kg/h]	$v$	Specific steam volume at $T_1$ and $p_2$ or – if $\Delta p > \frac{p_1}{2}$ – at $\frac{p_1}{2}$	[m <sup>3</sup> /kg]
$\dot{V}_N$	Volume flowrate for gases at standard state (0 °C, 1013 mbar)	[m <sup>3</sup> /h]	$T_1$	Absolute inlet temperature of fluid	[K]
$p_1$	Upstream pressure	[bar a]	$x$	Content of dry saturated steam in wet steam	(0 < $x$ ≤ 1)
$p_2$	Downstream pressure	[bar a]			
$\Delta p$	Pressure drop $p_1 - p_2$	[bar]			

### $K_v$ Values at Control Stroke $H_{100}$

See page 4: The characteristic lines in the upper part of the chart indicate simultaneously the  $k_v$  values.

	DN	$k_v$ values [m <sup>3</sup> /h]		Control stroke $H_{100}$ [mm]
		4 stages $\Delta p_{max}$ 300 bar (4350 psi)	6 stages $\Delta p_{max}$ 560 bar (8120 psi)	
ZK 213-...1/...	80 – 125 mm (3 – 5")	13	10	50
ZK 213-...2/...	100 – 150 mm (4 – 6")	26	20	60
ZK 213-...3/...	125 – 200 mm (5 – 8")	39	30	70
ZK 213-...4/...	150 – 250 mm (6 – 10")	60	46	70

### Correction factor for water flowrates (without flashing)



**Control Valve**  
**With Radial Stage Nozzle ZK and**  
**Tandem Shut-Off**  
**ZK 213**  
**DN 80 – 250**

**Order and Enquiry Specifications**

Control valve with radial stage nozzle ZK and tandem shut-off ZK 213.

Design data:  $p = \dots$  bar  $t = \dots$  °C

Operational data: Load Conditions (1 – 3)

	1	2	3
$p_1$ [bar]			
$t_1$ [°C]			
$p_2$ [bar]			
$\Delta p$ [bar]			
$\dot{m}$ [t/h]			

Please enter data in this table.

Fluid: .....

Actuators: Electric (make)

On-off or modulating control

Voltage/Hz.../...

Control voltage/Hz.../...

for electro-hydraulic  
 linear actuators indicate  
 on-off or modulating control  
 $\Delta p$  max in bar for sizing of  
 actuator

The following test certificates can be issued on request,  
 at extra cost:

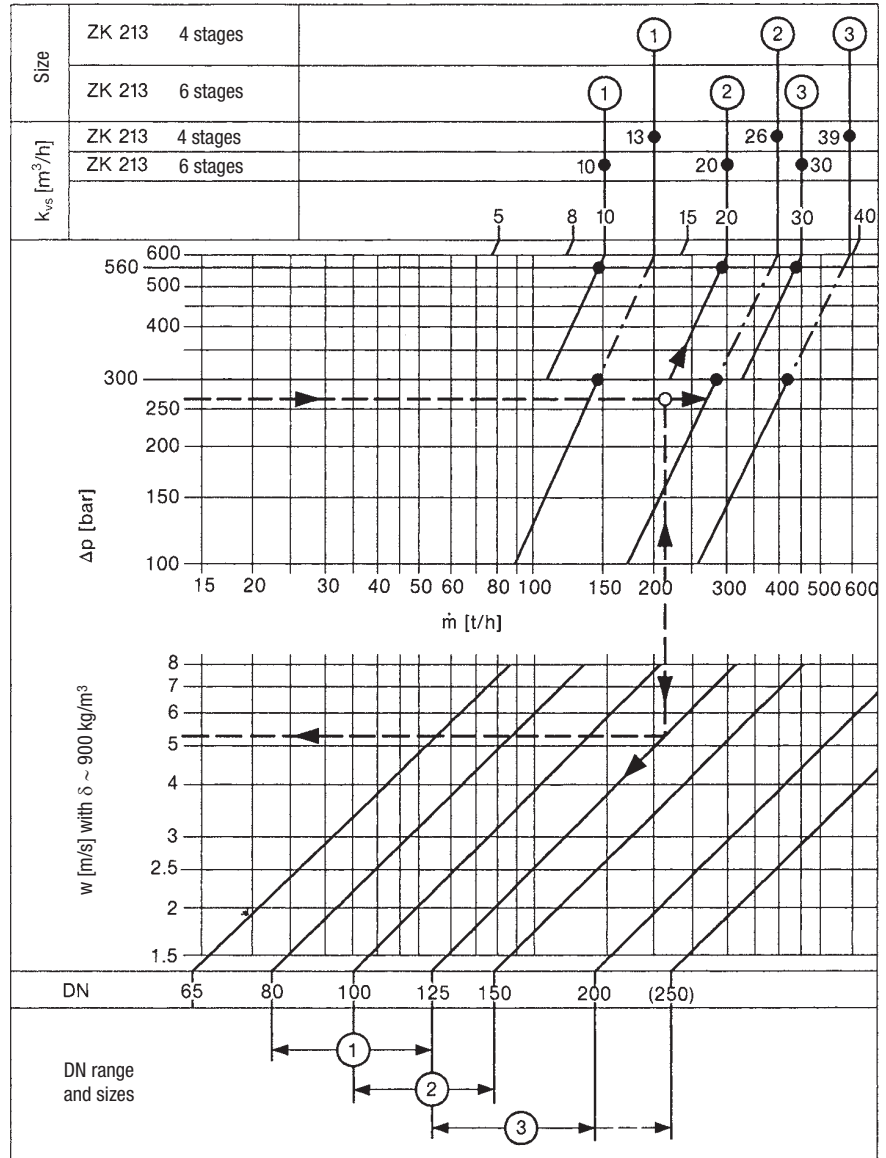
In accordance with EN 10204/-2.1, -2.2, -3.1A, -3.1B  
 and -3.1C.

All inspection requirements have to be stated with the order.  
 After supply of the equipment certificates can no longer be  
 established. Charges and extent of the above mentioned  
 certificates as well as the different tests confirmed therein  
 are listed in our leaflet "Test and Inspection Charges for  
 Standard Equipment". For other tests and inspections than  
 those listed above, please consult us.

Supply in accordance with our general terms  
 of business.

**Leak-off valves ZK 213**

Chart for determination of size, nominal size and flow velocity  $v$  in the pipe



**Example: Sizing of a leak-off valve.**

Operating conditions:

Upstream pressure  $p_1 = 285$  bar

Feedwater temperature  $t = 210$  °C

Back pressure  $p_2 = 15$  bar

Flowrate  $\dot{m} = 210$  t/h

Differential pressure across the leak-off valve  $\Delta p = 270$  bar (upstream pressure minus back pressure)

In accordance with the above chart, the required  $k_v$  value for a flowrate of 210 t/h is 20 m<sup>3</sup>/h.

Since the differential pressure  $\Delta p$  is lower than 300 bar, the ZK 213 with 4 stages, size 2, with a  $k_v$  value of 26 m<sup>3</sup>/h is selected.

For each valve size 3 different nominal sizes are available;  
 for size 2 these are DN 100, 125 and 150 (4, 5 and 6").

For leak-off lines we recommend flow velocities between 4 and 8 m/s.

From the lower part of the chart indicating the flow velocities we can read a velocity of 5.4 m/s for DN 125, i.e. DN 125 mm should be selected.

**Flowserve GESTRA U.S.**

2341 Ampere Drive  
 Louisville, KY 40299  
 Tel.: 001502 / 2672205, 001502 / 2672206  
 Fax: 001502 / 2665397  
 Email: dgoodwin@flowserve.com



GESTRA

## GESTRA Steam Systems

## Product Range

### Continuous Blowdown Valve Reaktomat®

**BA 46 / BA 46-ASME, PN 40/CL 150/300, DN 15-DN 50**

**BA 47 / BA 47-ASME, PN 63/CL 600, DN 25, 40, 50**

**BAE 46... / BAE 46...-ASME, PN 40/CL 150/300, DN 15-DN 50**

**BAE 47... / BAE 47...-ASME, PN 63/CL 600, DN 25, 40, 50**

**BA 46 / BA 46-ASME**

**BA 47 / BA 47-ASME**

**BAE 46... / BAE 46...-ASME**

**BAE 47... / BAE 47...-ASME**

### Description

Due to the continuous evaporation process in the steam boiler the density and hence the TDS (= Total Dissolved Solids) concentration of the boiler water is increased. The TDS level must remain within the limits specified by the boiler manufacturer and applicable guidelines. For this purpose a certain amount of boiler water (= boiler blowdown) is discharged continuously or periodically. The continuous blowdown valves BA... and BAE... feature specially designed and wear resistant nozzle stems that enter concentrically into a system of expansion chambers which are arranged one after the other, making the valve well suited for the continuous discharge of boiler blowdown at very high differential pressures. The continuous blowdown valves BA... and BAE... are suitable for operation in steam boiler plants according to TRD 604, EN 12952 and EN 12953.

- **BA 46** PN 40, manually operated
- **BA 47** PN 63, manually operated
- **BAE 46** PN 40, operated by the electric actuator **EF 1**<sup>1)</sup>
- **BAE 46-1** PN 40, operated by the electric actuator **EF 1-1**<sup>1)</sup>
- **BAE 46-3** PN 40, operated by the electric actuator **EF 0.6**<sup>1)</sup>
- **BAE 46-4** PN 40, operated by the electric actuator **EF 1-40**<sup>1)</sup>, <sup>2)</sup>
- **BAE 47** PN 63, operated by the electric actuator **EF 1**<sup>1)</sup>
- **BAE 47-1** PN 63, operated by the electric actuator **EF 1-1**<sup>1)</sup>
- **BAE 47-4** PN 63, operated by the electric actuator **EF 1-40**<sup>1)</sup>, <sup>2)</sup>

<sup>1)</sup> Explosion-proof actuators or actuators powered by d. c. or three-phase current are available on request.

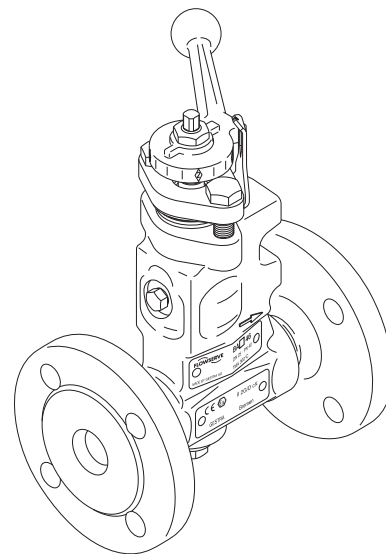
<sup>2)</sup> Actuator with CAN bus control

### Function

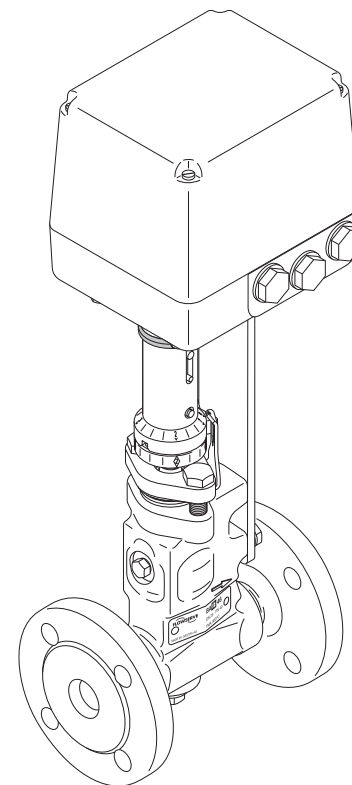
The continuous blowdown valve BA 46, BA 47 is moved to its control position by means of the control lever. Use the scale on the control lever to adjust the required amount of boiler blowdown. The required amount of boiler blowdown is calculated with the aid of a formula or read off on a nomogram. The continuous blowdown valve BAE 46..., BAE 47 is motored to its control position by means of the actuator EF... The actuator is activated by the GESTRA conductivity controller KS 90 working in conjunction with the GESTRA conductivity electrode LRGT 1... or the conductivity controller LRR 1-5, LRR 1-6 in combination with the GESTRA conductivity electrode LRG 1... or the conductivity controller LRR 1-40 in conjunction with the conductivity electrode LRG 1...-40.

The actuator opens or closes the continuous blowdown valve as a function of the required amount of boiler blowdown and the desired operating position, at which – independent of the actual electrical conductivity of the boiler water – a freely selectable basic amount can be discharged by the BAE 46..., BAE 47... The valve positions OPEN and CLOSED are limited by the cam-operated switch located in the actuator, the OPERATING POSITION is variably adjustable by means of an operating cam or a feedback potentiometer. The power flow towards the closing direction is transmitted via a coupling with integrated torsion spring. The coupling permits the actuator to travel a little bit further when the nozzle stem is pressed into the valve seat.

The conductivity of the boiler water is monitored by the equipment combination consisting of a conductivity electrode and a conductivity controller. The continuous evaporation process in the steam boiler increases the boiler water density and, consequently, the TDS level, causing the conductivity of the boiler water to rise. Once the set limit is reached, the actuator receives an opening signal from the conductivity controller as a function of the deviation from the conductivity setpoint. When the adjusted conductivity setpoint is attained, the actuator closes the continuous blowdown valve or returns to the adjusted operating position. The valve positions CLOSED and OPEN are limited by the cam-operated switch located in the actuator, the OPERATING POSITION is variably adjustable by means of an operating cam or a feedback potentiometer.



BA 46, BA 47



BAE 46..., BAE 47...

## Temperature/Pressure Ratings & End Connections

BA 46, BAE 46, Flanged PN 40, EN 1092-1 (2001), 1.0460 *)				
$p_{max}$ (max. pressure)	[bar]g	29		
$t_s$ (boiling temperature)	[°C]	234		

Calculated in accordance with DIN EN 12516-2, \*) material according to AD 2000

BA 46, BAE 46, Flanged PN 40, EN 1092-1 (2001), A 105				
$p_{max}$ (max. pressure)	[bar]g	36		
$t_s$ (boiling temperature)	[°C]	246		

Calculated in accordance with DIN EN 12516-2

BA 47, BAE 47, Flanged PN 63 / PN 100, EN 1092-1 (2001), 1.0460 *)				
$p_{max}$ (max. pressure)	[bar]g	44		
$t_s$ (boiling temperature)	[°C]	257		

Calculated in accordance with DIN EN 12516-2, \*) material according to AD 2000

BA 47, BAE 47, Flanged PN 63 / PN 100, EN 1092-1 (2001), A 105				
$p_{max}$ (max. pressure)	[bar]g	55		
$t_s$ (boiling temperature)	[°C]	271		

Calculated in accordance with DIN EN 12516-2

BA 4..., BAE 4...-ASME, Flanged B16.5 Class 150, butt-weld ends B16.25, socket-weld ends B16.11, Class 3000				
$p_{max}$ (max. pressure)	[bar]g	14		
$t_s$ (boiling temperature)	[°C]	198		
$p_{max}$ (max. pressure)	[psi]g	203		
$t_s$ (boiling temperature)	[°F]	388		

Calculated in accordance with ASME B16.34

BA 4..., BAE 4...-ASME, Flanged B16.5 Class 300, butt-weld ends B16.25, socket-weld ends B16.11, Class 3000				
$p_{max}$ (max. pressure)	[bar]g	42		
$t_s$ (boiling temperature)	[°C]	254		
$p_{max}$ (max. pressure)	[psi]g	609		
$t_s$ (boiling temperature)	[°F]	489		

Calculated in accordance with ASME B16.34

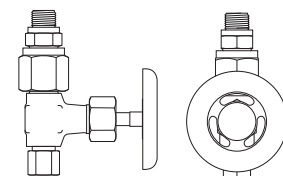
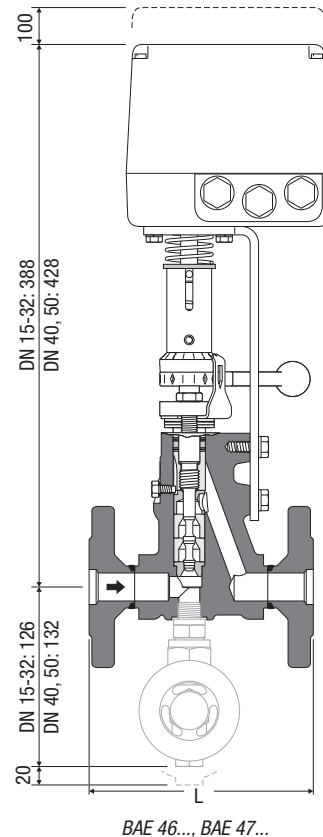
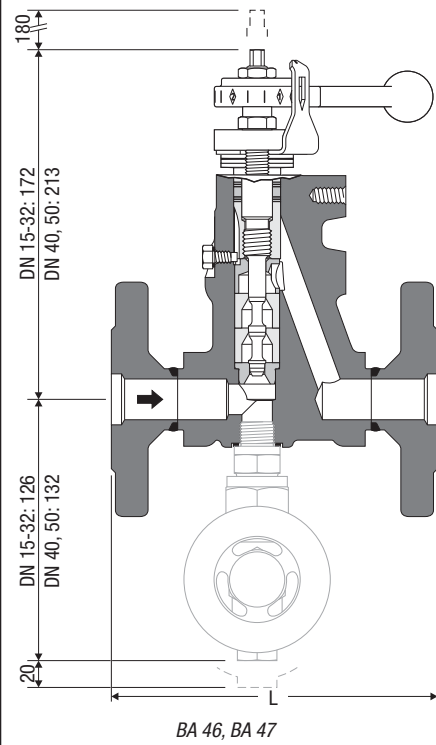
BA 4..., BAE 4...-ASME, Flanged B16.5 Class 400/600, butt-weld ends B16.25, socket-weld ends B16.11, Class 3000				
$p_{max}$ (max. pressure)	[bar]g	55		
$t_s$ (boiling temperature)	[°C]	270		
$p_{max}$ (max. pressure)	[psi]g	797		
$t_s$ (boiling temperature)	[°F]	518		

Calculated in accordance with ASME B16.34

## Materials

Type	BA 4..., BAE 4...	BA 4... ASME, BAE 4... ASME
Designation	DIN / EN	ASTM
Body	1.0460	A 105
Nozzle stem	1.4021	A 276 Grade 420
Seat and stage sleeves	1.4104	430F
Locking screw	A2-70	A 192 CL 2B-BB
Sealing plug	1.7225	A193 B7

## Dimensions



Sample valve G $\frac{3}{8}$  / Ermeto 8S

### Dimensions of flanged ends (extract)

DN	EN 1092-1, PN 40						EN 1092-1, PN 63			
	[inch]	½	¾	1	1¼	1½	2	1	1½	2
[mm]	15	20	25	32	40	50	25	40	50	
GB	95	105	115	140	150	165	140	170	180	
b	16	18	18	18	18	20	24	26	26	
k	65	75	85	100	110	125	100	125	135	
g	45	58	68	78	88	102	68	88	102	
l	14	14	14	18	18	18	18	22	22	
n	4	4	4	4	4	4	4	4	4	
L	150	150	160	180	200	230	190	220	250	
[kg] *)	4.7/8.8	5.3/9.4	5.8/9.9	7.1/11.2	10.7/14.8	12.5/16.6	7.1/11.2	10.7/14.8	12.5/16.6	

\*) Weight BA 4... / Weight BAE 4...

DN	ASME B16.5, Class 150									
	[inch]	½	¾	1	1¼	1½	2			
[mm]	15	20	25	32	40	50				
GB	88.9	98.4	107.9	117.5	127.0	152.4				
b	11.1	12.7	14.3	15.9	17.5	19.0				
k	60.3	69.8	79.4	88.9	98.4	120.6				
g	34.9	42.9	50.8	63.5	73.0	92.1				
l	15.9	15.9	15.9	15.9	15.9	19.0				
n	4	4	4	4	4	4				
L	150	150	160	180	230	230				
[kg] *)	4.7/8.8	5.3/9.4	5.8/9.9	7.1/11.2	10.7/14.8	12.5/16.6				

\*) Weight BA 4... / Weight BAE 4...

DN	ASME B16.5, Class 300						ASME B16.5, Class 400			
	[inch]	½	¾	1	1¼	1½	2	1	1½	2
[mm]	15	20	25	32	40	50	25	40	50	
GB	95.2	117.5	123.8	133.3	155.6	165.1	123.8	155.6	165.1	
b	14.3	15.9	17.5	19.0	20.6	22.2	17.5	22.2	25.4	
k	66.7	82.5	88.9	98.4	114.3	127	88.9	114.3	127	
g	34.9	42.9	50.8	63.5	73.0	92.1	50.8	73.0	92.1	
l	15.9	19.0	19.0	19.0	22.2	19.0	19.0	22.2	19.0	
n	4	4	4	4	4	4	4	4	4	
L	150	150	160	180	230	230	216	216	250	
[kg] *)	4.7/8.8	5.3/9.4	5.8/9.9	7.1/11.2	10.7/14.8	12.5/16.6	7.1/11.2	10.7/14.8	12.5/16.6	

\*) Weight BA 4... / Weight BAE 4... Other designs available on request. Special dimensions, sizes and materials for end connections on request.

### Dimensions of butt-weld ends (extract)

DN	DIN 3239-1 DIN 2559-2						DIN 3239-1 DIN 2559-2			
	[inch]	½	¾	1	1¼	1½	2	1	1½	2
[mm]	15	20	25	32	40	50	25	40	50	
d <sub>2</sub>	22	28	34	32.0	38.0	40.0	34	49	61	
d <sub>1</sub>	17.3	22.3	28.5	21.8	27.3	34.1	28.5	42.5	54.5	
for pipe	21.3x2.0	26.9x2.3	33.7x2.6	42.6x2.6	48.3x2.6	60.3x2.9	33.7x2.6	48.3x2.9	60.3x2.9	
L	200	200	200	200	250	250	200	250	250	
[kg] *)	4.1/8.2	4.7/8.8	4.7/8.8	5.4/9.5	8.9/13.0	10.2/14.3	4.7/8.8	8.9/13.0	10.2/14.3	

\*) Weight BA 4... / Weight BAE 4...

DN	ASME B16.25, Schedule 40 ASME B36.10						ASME B16.25, Schedule 80 ASME B36.10			
	[inch]	½	¾	1	1¼	1½	2	1	1½	2
[mm]	15	20	25	32	40	50	25	40	50	
d <sub>2</sub>	22	28	34	43	49	61	34	49	61	
d <sub>1</sub>	15.7	20.9	26.6	35.1	40.9	52.5	24.3	38.1	49.3	
for pipe	21.3x2.8	26.7x2.9	33.4x3.4	42.2x3.6	48.3x3.7	60.3x3.9	33.4x4.5	48.3x5.1	60.3x5.5	
L	200	200	200	200	250	250	200	250	250	
[kg] *)	4.1/8.2	4.7/8.8	4.7/8.8	5.4/9.5	8.9/13.0	10.2/14.3	4.7/8.8	8.9/13.0	10.2/14.3	

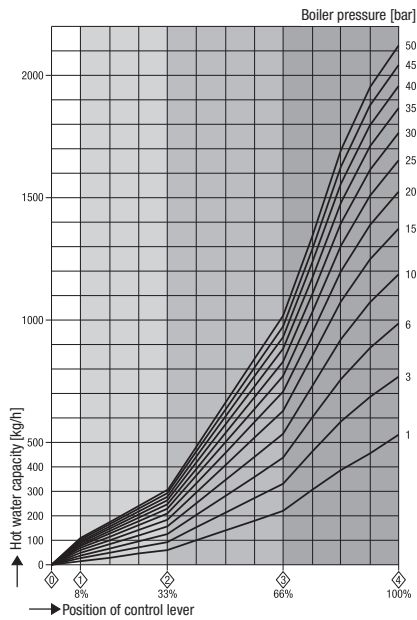
\*) Weight BA 4... / Weight BAE 4... Other designs available on request. Special dimensions, sizes and materials for end connections on request.

### Dimensions of socket-weld ends (extract)

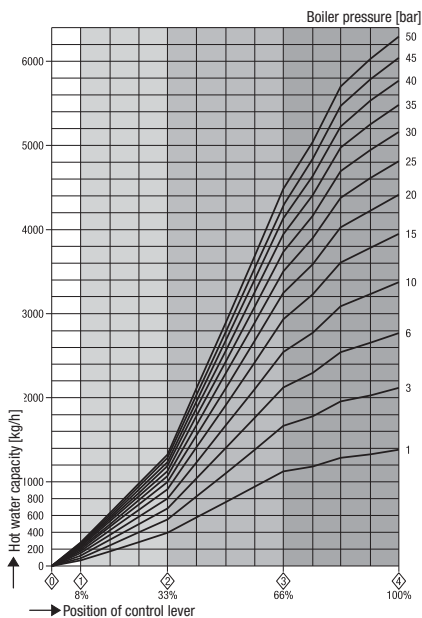
DN	DIN EN 12760, ASME B16.11, Class 3000									
	[inch]	½	¾	1	1¼	1½	2			
[mm]	15	20	25	32	40	50				
d <sub>2</sub>	32	37.5	46	55.5	62	75.5				
d <sub>1</sub>	21.9	27.3	34	42.8	48.9	61.3				
b	10	13	13	13	13	16				
for pipe	21.3/21.3	26.9/26.7	33.7/33.4	42.4/42.2	48.3/48.3	60.3/60.3				
L	200	200	200	200	250	250				
[kg] *)	5.1	5.1	5.1	5.1	5.1	5.1				

\*) Weight BA 4... / Weight BAE 4... Other designs available on request. Special dimensions, sizes and materials for end connections on request.

## Capacity Charts



**Fig. 1** For DN 15 to 32  
Capacity ranges at a glance



**Fig. 5** For DN 40 to 50  
Capacity ranges at a glance

### Calculating the amount of boiler blowdown

#### Example

Boiler pressure: 15 bar  
 Nominal size of continuous blowdown valve: DN 20  
 Boiler capacity:  $Q = 10000$  kg/h  
 Conductivity of feedwater:  $S = 100$   $\mu$ s/cm  
 Admissible conductivity of boiler water:  $K = 3000$   $\mu$ s/cm  
 Amount of boiler water to be discharged:  $A \approx 345$  kg/h  
 approx. 10 % of which is intermittently blown out:  $\approx 35$  kg/h  
 Amount of continuous blowdown:  $A_1 \approx 310$  kg/h  
 Set control level according to scale to an opening of 41%. (**Fig. 3**)

Amount of boiler water to be discharged

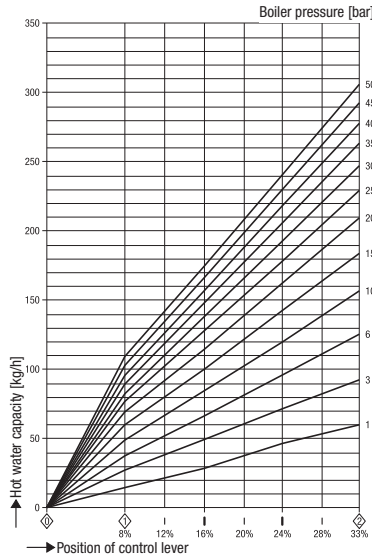
$$A = \frac{Q \cdot S}{K - S}$$

$A$  = Amount of boiler water to be discharged [kg/h]

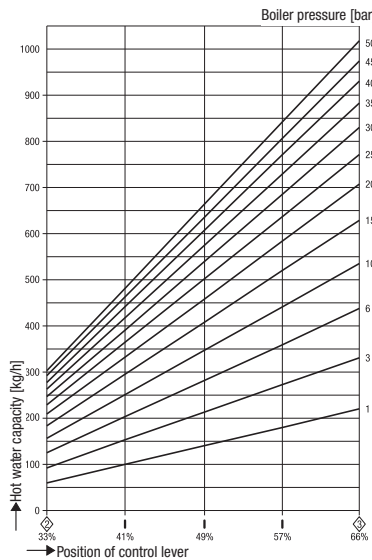
$Q$  = Boiler capacity [kg/h]

$S$  = Conductivity of feedwater [ $\mu$ s/cm]

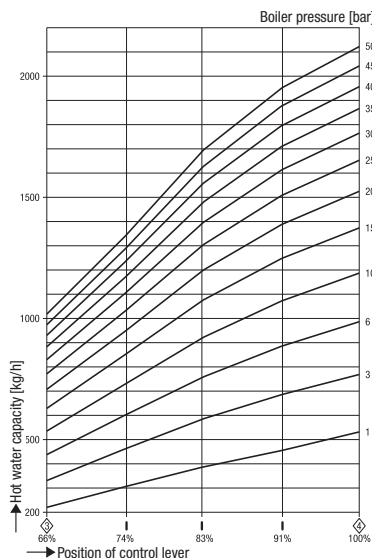
$K$  = Admissible conductivity of Boiler water [ $\mu$ s/cm]



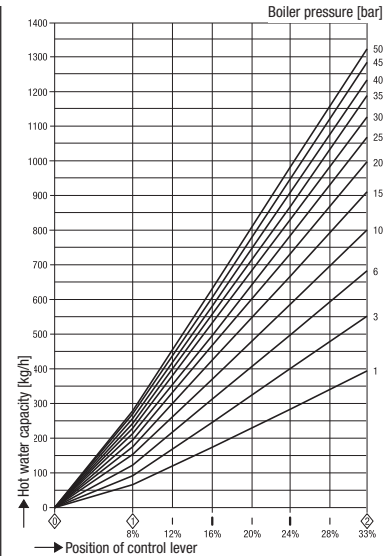
**Fig. 2** For DN 15 to 32  
Capacity range up to 310 kg/h



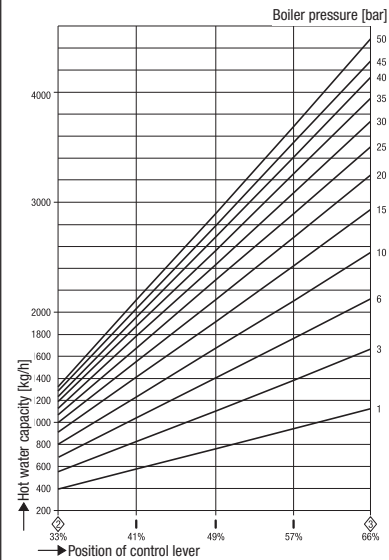
**Fig. 3** For DN 15 to 32  
Capacity range up to 1,020 kg/h



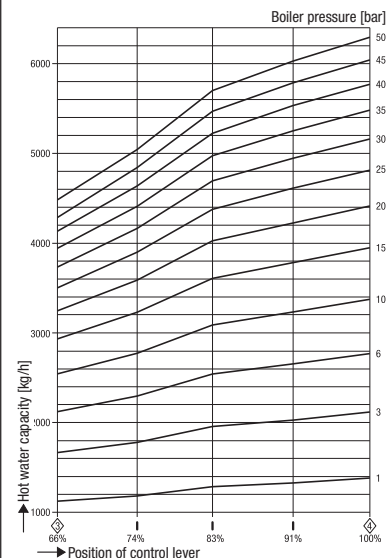
**Fig. 4** For DN 15 to 32  
Capacity range up to 2,120 kg/h



**Fig. 6** For DN 40 and 50  
Capacity range up to 1,340 kg/h

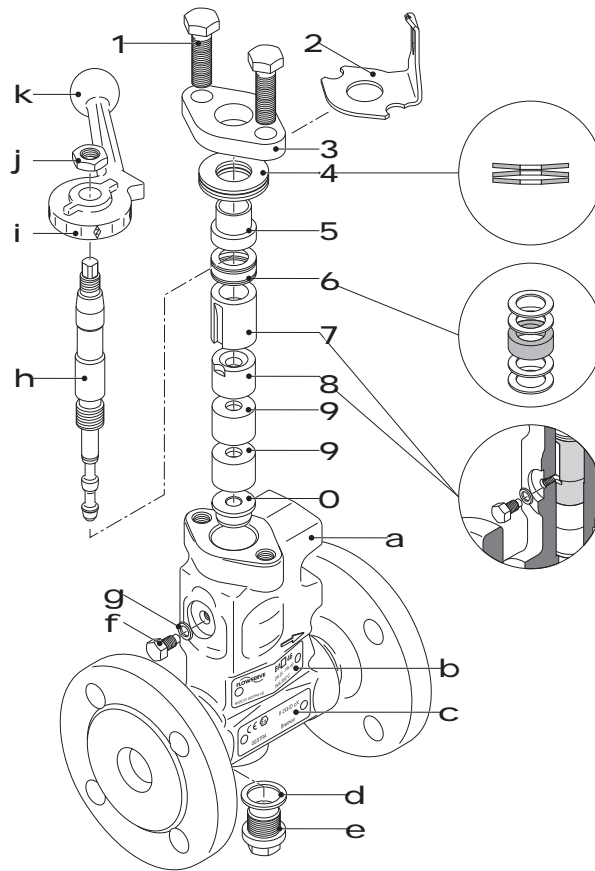


**Fig. 7** For DN 40 and 50  
Capacity range up to 4,500 kg/h



**Fig. 8** For DN 40 and 50  
Capacity range up to 6,300 kg/h

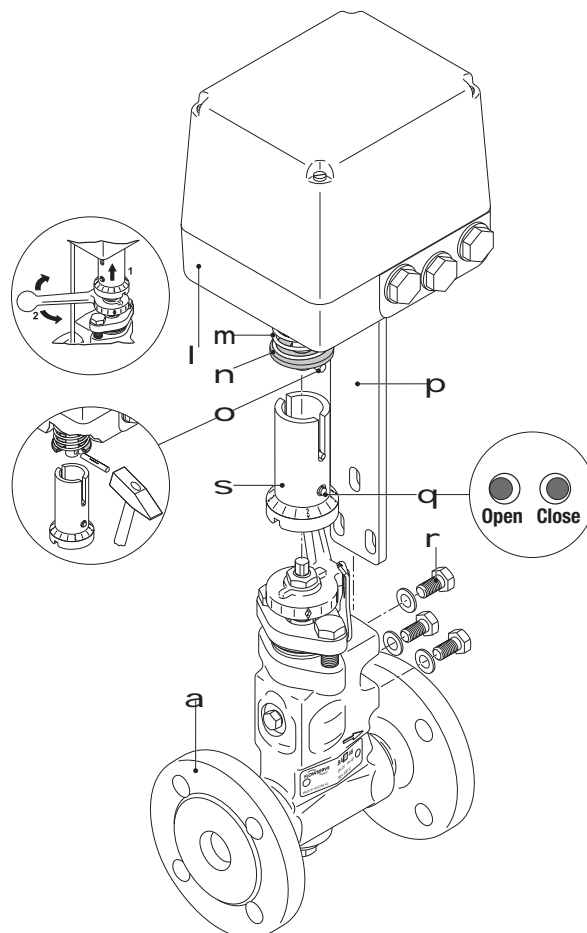
**Component Parts  
BA 46, BA 47**



**Key**

- 1** Stuffing box screw
- 2** Scale plate
- 3** Stuffing box gland
- 4** Disk spring (3 pieces)
- 5** Spring sleeve
- 6** Packing with 4 wiper rings
- 7** Guide sleeve
- 8** Wear resisting sleeve
- 9** Stage bushing
- O** Seat bushing
- a** Valve body
- b** Name plate
- c** ATEX marking
- d** Gasket A 17 x 23 x 1.5
- e** Sealing plug (connection for sample valve)
- f** Locking screw
- g** Gasket C6 x 10 x 1.5 (DN 15-32)  
C10 x 16 x 1.5 (DN 40, 50)
- h** Nozzle stem
- i** Scale
- j** Hexagon nut
- k** Control lever
- l** Actuator
- m** Compression spring
- n** Thrust washer
- O** Grooved dowel pin ISO 8742
- p** Mounting bracket
- q** Checking pin
- r** Hexagon screw with washer
- S** Coupling

**Component Parts  
BAE 46..., BAE 47...**



Continuous Blowdown Valve Reaktomat®  
**BA 46 / BA 46-ASME,**  
**PN 40/CL 150/300, DN 15-DN 50**  
**BA 47 / BA 47-ASME,**  
**PN 63/CL 600, DN 25, 40, 50**  
**BAE 46... / BAE 46...-ASME,**  
**PN 40/CL 150/300, DN 15-DN 50**  
**BAE 47... / BAE 47...-ASME,**  
**PN 63/CL 600, DN 25, 40, 50**

**When ordering please state:**

Steam pressure, design, end connection, size, type and place of installation

The following test certificates can be issued on request, at extra cost:

In accordance with EN 10204-2.1, -2.2, 3.1 and 3.2.

All inspection requirements have to be stated with the order. After supply of the equipment certification cannot be established. Charges and extent of the above mentioned certificates as well as the different tests confirmed therein are listed in our price list "Test and Inspection Charges for Standard Equipment". For other tests and inspections than those listed above, please consult us.

**PED (Pressure Equipment Directive)**

The equipment fulfils the requirements of the Pressure Equipment Directive PED 97/23/EC. For use with fluids of group 2. With CE marking (apart from equipment that is excluded from the scope of the PED as specified in section 3.3).

**ATEX (Atmosphère Explosible)**

The equipment BA 46, BA 47 can be used in potentially explosive areas, provided that the following notes are observed: The service fluid must not generate excessively high operating temperatures. Electrostatic charges that may be produced during operation must be discharged. The tight shut-off of the stuffing box must be ensured. The valve spindle must be able to move smoothly. Applicable in Ex zones 1, 2, 21, 22 (1999/92/EC), **CE** II 2 G/D c X. According to the European Directive 94/9/EC the equipment BAE 46..., BAE 47... must not be used in potentially explosive areas. For more information refer to our ATEX Declaration of Conformity.

Supply in accordance with our general terms of business.

**Spare parts list**

Item	Designation	Stock code	Stock code
		BA 46 BA 47	BAE 46... BAE 47...
6 d g	Packing & gasket kit, DN 15 to DN 32: 1 Packing ring 15 x 23 x 8, 4 wiper rings, 1 gasket C 6 x 10 x 1.5, 1 gasket A 17 x 23 x 1.5	335702	335702
6 d g	Packing & gasket kit, DN 40 and DN 50: 1 Packing ring 18 x 28 x 10, 4 wiper rings, 1 gasket C 10 x 16 x 1.5, 1 gasket A 17 x 23 x 1.5	335704	335704
6 7 8 9 0 d g h	Complete spare parts kit, DN 15 to DN 32: 1 nozzle stem, 1 seat bushing, 2 stage bushings, 1 wear resistant sleeve, 1 guide sleeve, 1 packing ring 15 x 23 x 8, 4 wiper rings, 1 gasket C 6 x 10 x 1.5, 1 gasket A 17 x 23 x 1.5	335703	335703
6 7 8 9 0 d g h	Complete spare parts kit, DN 40 and DN 50: 1 nozzle stem, 1 seat bushing, 2 stage bushings, 1 wear resistant sleeve, 1 guide sleeve, 1 packing ring 18 x 28 x 10, 4 wiper rings, 1 gasket C 10 x 16 x 1.5, 1 gasket A 17 x 23 x 1.5	335705	335705
I	Actuator <b>EF 0.6</b> , 230 V, 50/60 Hz (for BAE 46-3)		335932
I	Actuator <b>EF 1</b> , 230 V, 50/60 Hz (for BAE 46, BAE 47)		335929
I	Actuator <b>EF 1-1</b> , 230 V, 50/60 Hz (for BAE 4...-1)		335931
I	Actuator <b>EF 1-40</b> , 230 V, 50/60 Hz (for BAE 4...-4)		335952

Explosion-proof actuators or actuators powered by d. c. or three-phase current are available on request.

**List of parts for retrofitting**

Item	Designation	Stock code	Stock code
		BA 46 BA 47	BAE 46... BAE 47...
I m n o p r s	1 actuator <b>EF 0.6</b> , 230 V, 50/60 Hz, 1 mounting bracket, 1 assembly set for coupling, 3 hexagon screws (for BAE 46-3)	335658	
	1 actuator <b>EF 1</b> , 230 V, 50/60 Hz, 1 mounting bracket, 1 assembly set for coupling, 3 hexagon screws (for BAE 46..., BAE 47...)	335659	
	1 actuator <b>EF 1-1</b> , 230 V, 50/60 Hz, 1 mounting bracket, 1 assembly set for coupling, 3 hexagon screws (for BAE 4...-1)	335660	
	1 actuator <b>EF 1-40</b> , 230 V, 50/60 Hz, 1 mounting bracket, 1 assembly set for coupling, 3 hexagon screws (for BAE 4...-4)	335661	
	1 mounting bracket, 1 assembly set for coupling, 3 hexagon screws (without actuator I )	335769	

**Flowserve GESTRA U.S.**

2341 Ampere Drive  
Louisville, KY 40299  
Tel.: (502) 267-2205  
Fax: (502) 266-5397  
Email: fcd-gestra-usa@flowserve.com



GESTRA



## GESTRA Steam Systems

Product Range A3

Continuous Blowdown Valves

**Reactomats**

**BA 28, BA 29, BA 210, BA 211**

**PN 63 – 320, DN 25 mm (1")**

**BA 28**

**BA 29**

**BA 210**

**BA 211**

### Description

The valve is connected to the water space of the boiler. Precise adjustment of blowdown rate by turning regulating lever on the calibrated scale plate (see charts on back page).

With the regulating lever in blow-off position the capacity is approximately three times the capacity at scale division 100.

The BA includes a sampling valve for checking the boiler-water concentration.

### Application

Continuous blowdown of steam boilers, evaporators, quench coolers and similar installations. Regulating or dosing valve for all industries.

### Connections

Butt-weld ends for pipe according to DIN 2448:

30 x 2.6 to 4.5

31.8 x 2.6 to 5

33.7 x 3.6 to 6.3

38 x 5.6 to 8

ANSI B 36.10: 1" Schedule 80 and 160

Other dimensions or weld-neck flanges on request at extra cost.

### Design

Straight-through valves with butt-weld ends, weld-neck flanges at extra cost. With GESTRA stage-nozzle, regulating lever, calibrated scale and sampling valve.

On request with electric actuator as BAE 28 – 211.



BA 28 – BA 211

### Range

If used as continuous blowdown valve (at saturation temperature):

BA 28 max. 63 bar g (915 psig)

BA 29 max. 94 bar g (1360 psig)

BA 210 max. 142 bar g (2060 psig)

BA 211 max. 226 bar g (3280 psig)

Max. temperature			°C	120	200	250	300	350	400	450	500	530
Max. service pressure	BA 28	PN 63/100	barg	100	80	70	60	56	50	–	–	–
			psig	1450	1160	1015	870	810	725	–	–	–
	BA 29	PN 160*)	barg	160	130	112	96	90	80	–	–	–
			psig	2320	1885	1625	1390	1305	1160	–	–	–
BA 210	PN 250*)	barg	250	200	175	150	140	125	–	–	–	
		psig	3625	2900	2540	2175	2030	1810	–	–	–	
BA 211	PN 320*)	barg	320	320	320	320	304	292	278	237	124	
		psig	4640	4640	4640	4640	4410	4235	4030	3435	1800	

\*) For relatively small capacities (see charts) use BA 29k, 210k or 211k with special stage nozzle.

### Materials

#### BA 28

Body (two parts): forged steel C 22.8 (No. 1.0460 DIN)

Nozzle insert: cast stainless steel G-X 22 CrMoV 12 1 (1.4931)

Stage nozzle: stainless steel C 20 Cr 13 (1.4021)

#### BA 29

Body (two parts): C 22.8 (1.0460)

Nozzle insert\*): G-X 22 CrMoV 12 1 (1.4931)

Stage nozzle\*): stainless steel X 8 CrTi 17 (1.4510)

#### BA 210

Lower-body part: C 22.8 (1.0460)

Upper-body part\*): C 22.8 (1.0460)

Nozzle insert\*): G-X 22 CrMoV 12 1 (1.4931)

Stage nozzle\*): X 8 CrTi 17 (1.4510)

#### BA 211

Lower-body part: forged alloy steel 13 CrMo 44 (1.7335)

Upper-body part\*): 13 CrMo 44 (1.7335)

Nozzle insert\*): G-X 22 CrMoV 12 1 (1.4931)

Stage nozzle\*): X 8 CrTi 17 (1.4510)

\*) additionally armoured

### Order Specifications

Valve type, nominal pressure (PN), nominal size (DN), capacity, service pressure, back pressure, fluid, application (e.g. type of boiler).

The following test certificates can be issued on request, at extra cost:

In accordance with EN 10204-2.1, -2.2, -3.1A, -3.1B and -3.1C.

All inspection requirements have to be stated with the order. After supply of the equipment certification cannot be established. For tests and inspection charges please consult us.

### Enquiry Specification

Reactomats (continuous blowdown valves) with GESTRA stage nozzle, regulating lever, calibrated scale and sampling valve.

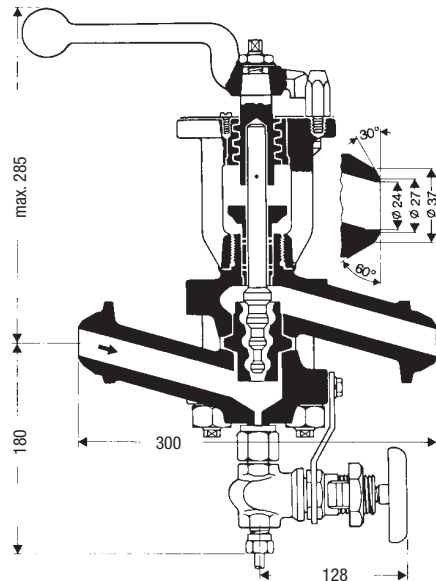
Application (optional) as continuous blowdown valve for steam boilers, evaporators and similar installations or as regulating/dosing valve.

Indications on nominal pressure (PN), nominal size (DN), type of connection, service pressure, back pressure, temperature, fluid, application (e.g. type of boiler).

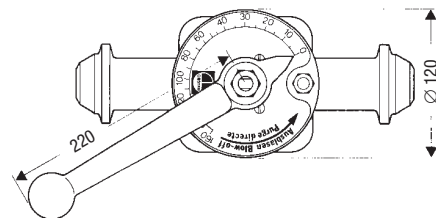
**Continuous Blowdown Valves  
Reactomats  
BA 28, BA 29, BA 210, BA 211  
PN 63 – 320, DN 25 mm (1")**

**Dimensions**

BA 28 – 211 (approx. weight 21 kg)



Sampling valve with compression fitting 8 mm O.D.



Supply in accordance with our general terms of business.

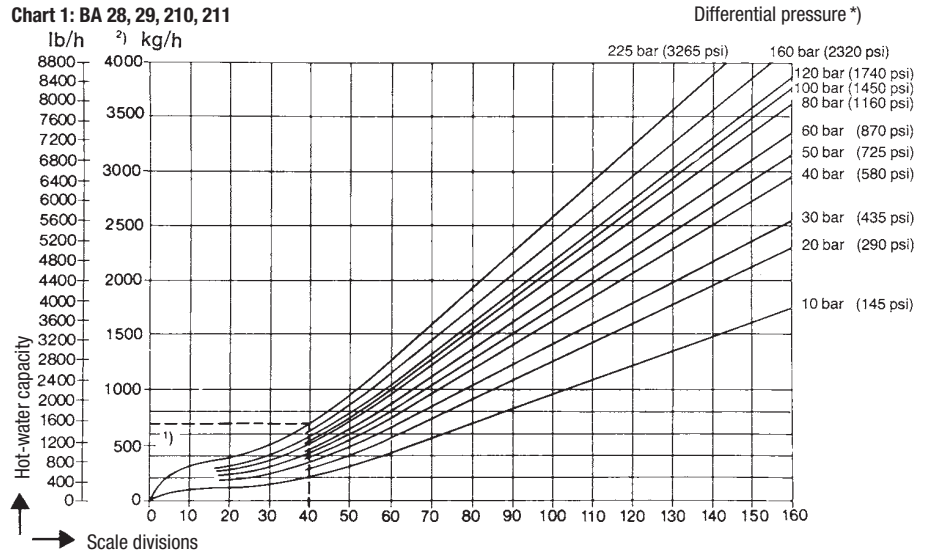
**Types, Capacity, Scale Division**

Selection of valve type according to pressure and temperature see under "Range".

Scale divisions for required capacity (blow-down quantity) see charts.

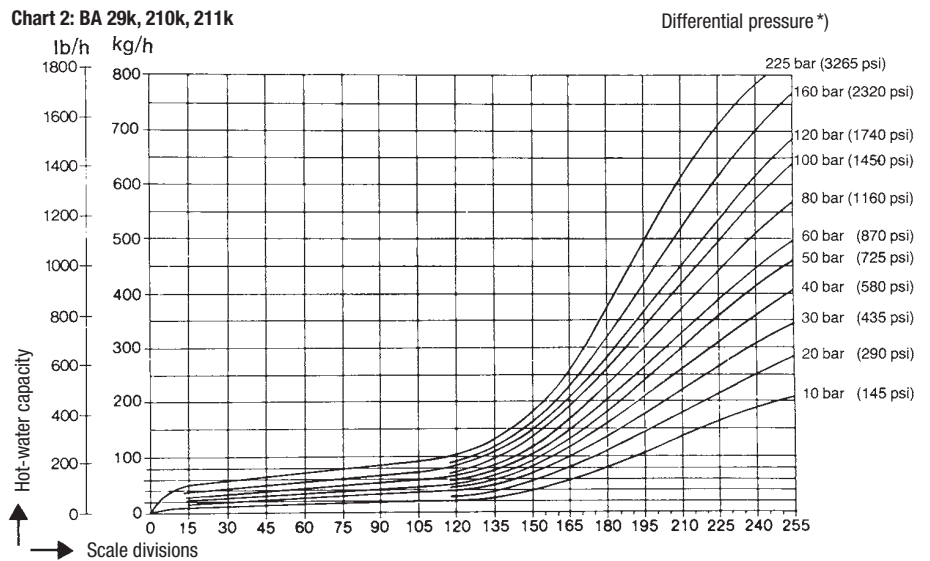
In blow-off position (regulating lever against stop) the capacity is approximately three times the capacity at scale division 100.

**Chart 1: BA 28, 29, 210, 211**



- 1) For relatively small quantities (see dotted lines in chart) use BA 29k, 210k or 211k (with special stage nozzle). Scale divisions according to chart 2.
- 2) If the quantity of boiler water to be discharged is higher than the values covered by chart 1, GESTRA Reactomats BA 39 with radial stage nozzle should be used.

**Chart 2: BA 29k, 210k, 211k**



- \*) Differential pressure (working pressure) = Inlet minus outlet pressure.
- If the boiler water is lifted after the Reactomat, the differential pressure is reduced by approximately 1 bar for 7 m (or 2 psi for 3 feet) in lift.

**Flowserve GESTRA U.S.**

2341 Ampere Drive  
Louisville, KY 40299  
Tel.: (502) 267-2205  
Fax: (502) 266-5397  
Email: fcd-gestra-usa@flowserve.com



## GESTRA Steam Systems

### Rapid-Action Intermittent Blowdown Valves

(M)PA 46, PN 40, DN 20-50

(M)PA 47, PN 63, DN 25, 40, 50

(M)PA 110, PN 250, DN 25

### Product Range B

(M)PA 46

(M)PA 47

(M)PA 110



#### Specification

Manual or automatic, programme-controlled intermittent blowdown of land and marine boilers, in particular boilers operating without constant supervision in accordance with TRD 604 (German regulations concerning the operation of steam boilers).

#### Description

The valves type MPA are provided with a diaphragm actuator suitable for compressed air or pressurized water and a rapid-closing mechanism. The opening pulse is supplied by the automatic intermittent blowdown control unit type TA (cf. data sheet TA) or by the continuous blowdown controller LRR 1-40 SPECTOR control with CAN bus (cf. data sheet LRR 1-40). The valves type PA are manually operated and feature a rapid-action mechanism.

#### Design

(M)PA 46 / (M)PA 47

Straight-through valves with rapid-closing mechanism and diaphragm actuator designed with flanged ends or butt-weld ends. MPA with diaphragm actuator, PA with hand lever (fastening clip). Self-tightening stuffing box with separate, externally adjustable preloading sleeve. The valve is provided with a radial stage nozzle.

(M)PA 110

Straight-through valve with rapid-closing mechanism and diaphragm actuator designed with flanged ends or butt-weld ends. MPA with diaphragm actuator, PA with hand lever.

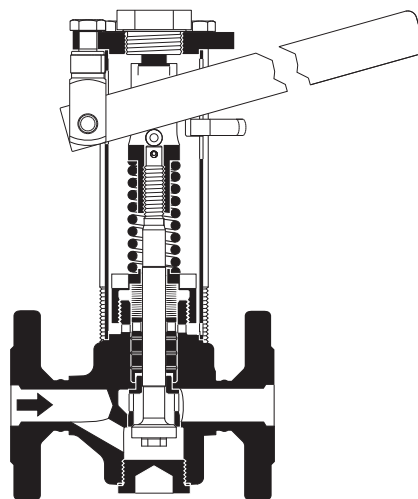
Connections		
Type	Standard	On request
(M)PA 46	Flanges PN 40	Flanges to Class 150, 300 Butt-weld ends for DIN or ASME pipes Socket-weld ends for DIN or ASME pipes
(M)PA 47	Flanges PN 63	Flanges to Class 600 Butt-weld ends for DIN or ASME pipes Socket-weld ends for DIN or ASME pipes
(M)PA 110	Butt-weld ends for DIN pipe 33.7 x 3.6	Other butt-weld ends Socket-weld ends to DIN or ASME Flanges acc. to DIN or ASME

Pressure Ratings			
(M)PA 46		PN 40	Class 150, 300
(M)PA 47		PN 63	Class 600
(M)PA 110		PN 250	Class 900/1500

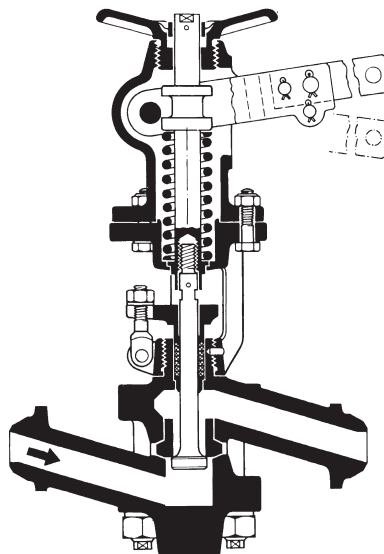
Materials (M)PA 46, (M)PA 47			
Designation	DIN EN	DIN reference	ASTMequivalent
Body	P250GH (1.0460)	C 22.8 (1.0460)	A 105
Stuffing box union	P250GH (1.0460)	C 22.8 (1.0460)	A 105
Sealing plug	42CrMo4 (1.7225)		A193 B7
Gasket	X5CrNi18-10 (1.4301)	X 5 CrNi 18 10 (1.4301)	
Seat, hardened	X46Cr13 (1.4034)	X 46Cr 13 (1.4034)	
Valve cone, hardened	X39CrMo17-1 (1.4122)	X 35 CrMo 17 (1.4122)	
Disk springs	51CrV4 (1.8159)	50 CrV 4 (1.8159)	
Compression springs	EN 10270-1-SH	DIN 17223-C	
Diaphragm actuator		StW 23 (1.0334)	
Packing		PTFE yarn	
Control fluid		EPDM	

Materials (M)PA 110			
Designation	DIN EN	DIN reference	ASTMequivalent
Body	13CrMo4-5	13 CrMo 4 4 (1.7335)	
Valve yoke	P250GH	C 22.8 (1.0460)	A 105
Seat, hardened	X6CrNiMoTi17-12-2	X6CrNiMoTi 17 12 2 (1.4571)	
Valve cone, hardened	X6CrNiMoTi17-12-2	X6CrNiMoTi 17 12 2 (1.4571)	
Bolt *)	21CrMoV5-7	21 CrMoV 5 7 (1.7709)	
Nut *)		24 CrMo 5 (1.7258)	A194 4
Packing		Graphite	
Valve head	EN-GJMW-350-4	GTW-35-04 (0.8035)	
Compression spring	EN 10270-1-SH	DIN 17223-C	

\*) Pressure-bearing part



PA 46 / PA 47



PA 110

## Blowdown Intervals and Blowdown Duration

When opening a GESTRA intermittent blowdown valve, its quick-opening action creates a suction effect causing the sludge to be blowdown. This desludging operation automatically provides simultaneous desalting.

A blowdown period – opening period of the valve – lasts approx. 2 seconds. To be able to determine the periods when blowdown is to be repeated it is necessary to know the quantity of boiler water to be discharged.

1. The formula on page 4 calculates the boiler-water quantity in kg/h to be discharged to keep the boiler-water conductivity below the admissible value, e. g.: 10 kg/h
2. Chart 1 gives the discharge capacity blowdown in kg/s for the existing valve or the valve suitable for the size of the boiler standpipe e.g. 2.5 kg/s
3. The blowdown duration can now be calculated, in this case 4 seconds per hour.  
Since the blowdown valve stays only open for 2 seconds during each blowdown operation, this implies 2 operations per hour. The blowdown interval is therefore  $60 : 2 = 30$  minutes.

The automatic intermittent blowdown control unit TA..., LRR 1-40 (see separate data sheets) provides the following programme:

Blowdown duration (opening period) normally 2 seconds.  
Blowdown interval adjustable, e. g. 30 minutes.

It is of course possible to adjust larger intervals, i.e. to blowdown less frequently and to use a GESTRA Reactomat BA or BAE for continuous desalting.

Heat recovery of continuous desalting processes provides significant energy and cost savings.

## Pressure / Temperature Ratings

Acc. to EN 1092-1 for: 1.0460 acc. to PED and AD 2000 or A 105 acc. to PED

	Ratings according to		max. pressure [bar] at [t] =					Max. actuating force PA... [N]		Control fluid MPA...	Max. control pressure MPA...
			100 °C	200 °C	300 °C	400 °C	ts/p max.	20 – 32	40, 50		
(M)PA 46	PN 40 1.0460	EN 1092-1	37.3	30.2	25.8		234/29	290	460	Water or compressed air	8 bar
	PN 40 A105	EN 1092-1	40	37.9	33.5		246/36	320	530		
	Class 150 A105	ASME B16.34	17.7	14.0	10.2		198/14	230	310		
(M)PA 47	Class 300 A105	ASME B16.34	46.4	43.9	38.9		254/41	340	580		
	PN 63 1.0460	EN 1092-1	58.8	47.6	40.6		257/44	360	620		
	PN 63 A105	EN 1092-1	63	59.6	52.7		271/55	410	730		
(M)PA 110	Class 400/600 A105	ASME B16.34	93.2	87.6	79.6		270/82	400	720	Compressed air	6 bar
	PN 250 1.7335	EN 1092-1	250	250	227.7	200	369/206	800			
	PN 250 A182-F12	EN 1092-1	250	250	243	226.5	374/221	850			
	Class 400/600 A182-F12	ASME B16.34	103	95.8	85.7	73.3	300/85	400			
	Class 900 A182-F12	ASME B16.34	154.4	143.9	128.6	109.8	326/124	540			
	Class 1500 A182-F12	ASME B16.34	257.4	239.7	214.4	183.1	363/196	790			

## Retrofit sets

Diaphragm actuator unit for PA 46 / 47: 335093

Comprises: diaphragm actuator with spacer disk

Manual emergency operating device for MPA 46 / 47: 335060

Comprises: emergency operating lever, clevis, toggle bolt, hexagon-head screw

Proximity switch

MPA 46 / 47: 335140

Comprises: two proximity switches, mounting bracket, two disconnecting switch amplifiers

## Enquiry Specification

MPA

Rapid-action intermittent blowdown valves with diaphragm actuator and rapid-closing mechanism.

Indications on nominal pressure (PN), nominal size (DN), connections, service pressure, back pressure, temperature, fluid, application (e. g. type of boiler).

Specifications on intermittent blowdown control: TA..., LRR 1-40, solenoid valves 230 V, 50/60 Hz.

PA

Rapid-action intermittent blowdown valve with hand-lever actuation, with rapid-closing mechanism and locking device.

Indications on nominal pressure (PN), nominal size (DN), connections, service pressure, back pressure, temperature, fluid, application (e. g. type of boiler).

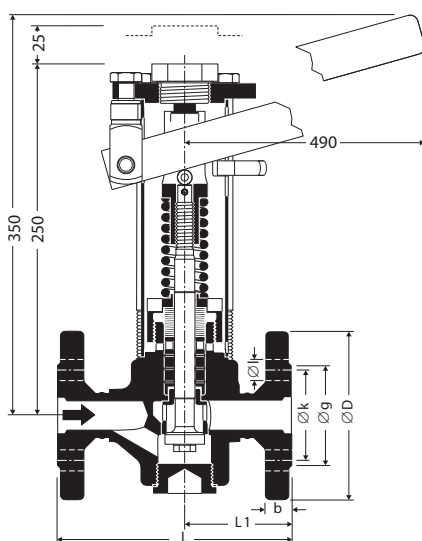
## Please note

When sizing pipes please take torsional and bending moments, which occur when the hand lever of PA... is set crosswise or lengthwise to the pipe, into account. The max. actuating forces are indicated in the table "Pressure / Temperature Rating".

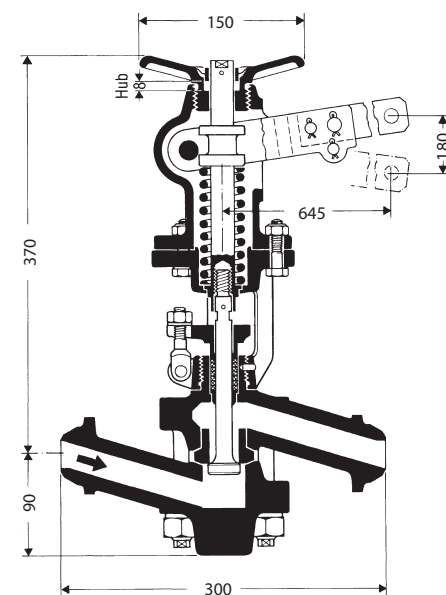
To avoid waterhammer we recommend that the pipe downstream of the intermittent blowdown valve has a downward inclination or to drain the pipe before carrying out the intermittent boiler blowdown.

The pipe length between the steam boiler and the intermittent blowdown valve must not exceed two meters!

PA 46 / PA 47



PA 110



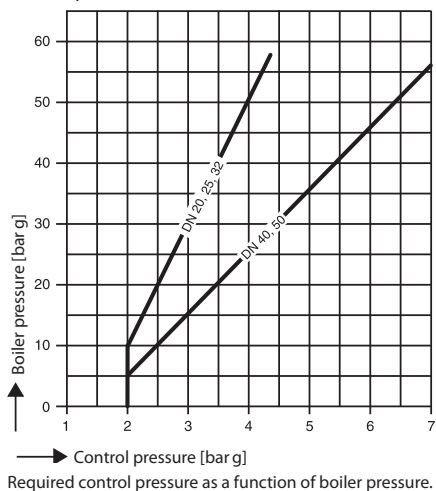
## Dimensions and weights

(M)PA 46, (M)PA 47 DN 20 – 50						
DN	[mm] [in]	20 ¾	25 1	32 1¼	40 1½	50 2
Flanged Class 150	L	150	160	180	230	230
	L1	68	73	83	98.5	98.5
Flanged Class 300	L	150	160	180	230	230
	L1	68	73	83	98.5	98.5
Flanged Class 400/600	L		216		216	250
	L1		101		91.5	108.5
Butt-weld ends via transition pieces	L	200	200	200	250	250
	L1	93	93	93	108.5	108.5
Socket-weld ends	L	200	200	200	250	250
	L1	93	93	93	108.5	108.5
Flanged DIN PN 40	L	150	160	180	200	230
	L1	68	73	83	83.5	98.5
	D	105	115	140	150	165
	k	75	85	100	110	125
	g	58	68	78	88	102
	b	18	18	18	18	20
	l	14	14	18	18	18
Number of bolts	n	4	4	4	4	4
	L		190		220	250
Flanged DIN PN 63	L1		88		73.5	108.5
	D		140		170	180
	k		100		125	135
	g		68		88	102
	b		24		26	26
	l		18		22	22
	n		4		4	4
Weight MPA [kg]	m	13.9	14.5	15.8	18.9	20.7
Weight PA [kg]	m	8.8	9.4	10.7	13.8	15.6

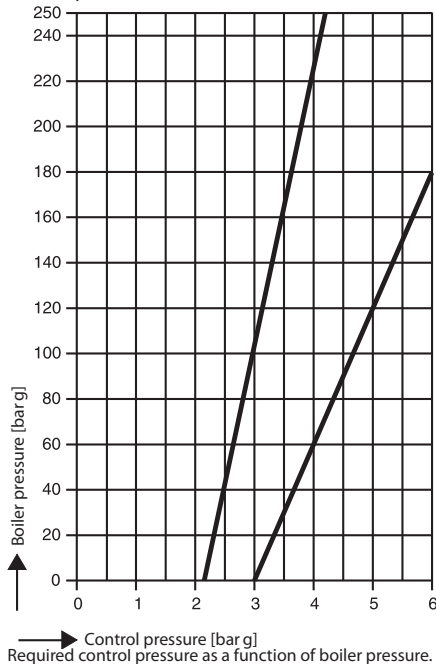
(M)PA 110, PN 250, DN 25						
DN	[mm] [in]	20 ¾	25 1	32 1¼	40 1½	50 2
Flanged DIN PN 100/160	L		390			
Flanged DIN PN 250	L		410			
Flanged Class 400/600	L		410			
Flanged Class 900/1500	L		440			
Butt-weld end	L		300			
Butt-weld ends via transition pieces	L		400			
Weight MPA 110 [kg] *)			37 (30)			
Weight PA 110 [kg] *)			29 (22)			

\*) Butt-weld ends and butt-weld ends via transition pieces

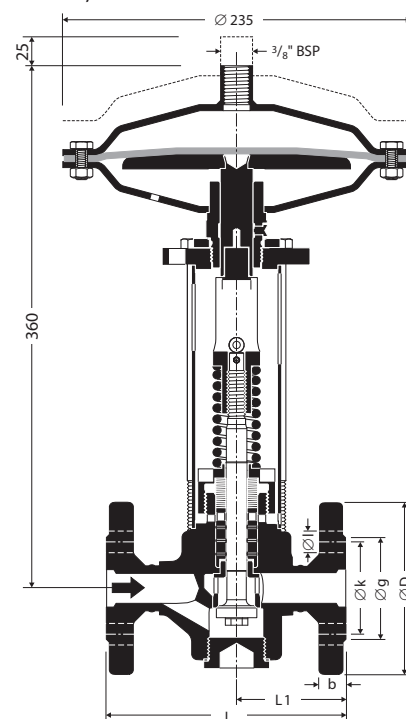
Control pressure (M)PA 46 / (M)PA 47



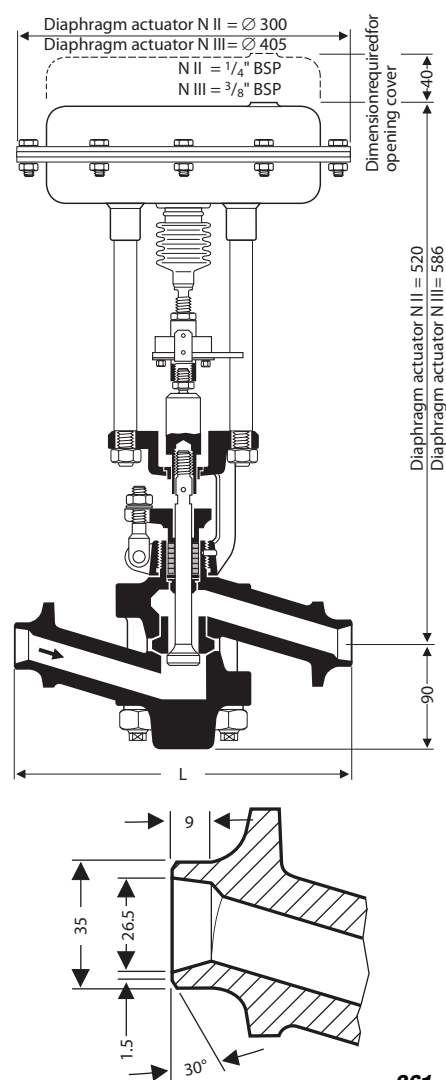
Control pressure (M)PA 110



MPA 46, MPA 47



MPA 110



## Rapid-Action Intermittent Blowdown Valves

(M)PA 46, PN 40, DN 20-50  
 (M)PA 47, PN 63, DN 25, 40, 50  
 (M)PA 110, PN 250, DN 25

Calculation of boiler water quantity to be discharged according to formula:

$$A = \frac{Q \cdot S}{K - S}$$

Conductivity of feedwater: S [µS/cm]

Admissible conductivity of boiler water: K [µS/cm]

Boiler capacity: Q [kg/h]

Boiler water quantity to be discharged: A [kg/h]

Example  
 Conductivity of feedwater: S = 20 µS/cm

Admissible conductivity of boiler water: K = 4000 µS/cm

Boiler capacity: Q = 2000 kg/h

Boiler water quantity to be discharged: A ≈ 10 kg/h

Reading chart 1

Boiler pressure: 25 bar

Nominal size of intermittent boiler blowdown: DN 32

Flowrate: 2.5 kg/s

### K<sub>v</sub>-values

(M)PA 46/47 DN 20, 25, 32	5.1 m <sup>3</sup> /h
(M)PA 46/47 DN 40, 50	16.5 m <sup>3</sup> /h
(M)PA 110 DN 25	6.1 m <sup>3</sup> /h

### When ordering please state

Steam pressure, backpressure, amount of condensate, connection, size (DN), application (e.g. type of boiler or steam user).

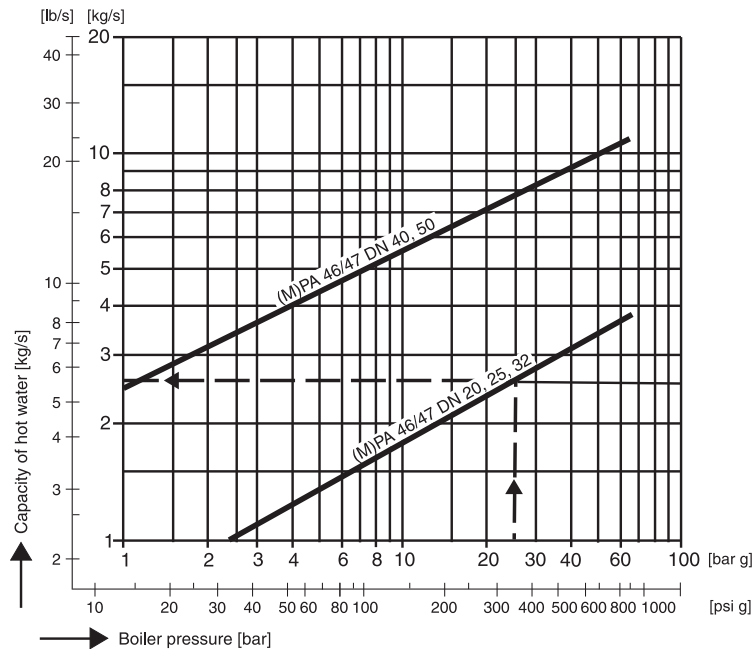
The following test certificates can be issued on request, at extra cost:

In accordance with EN 10204/2.2 and -3.1 B.

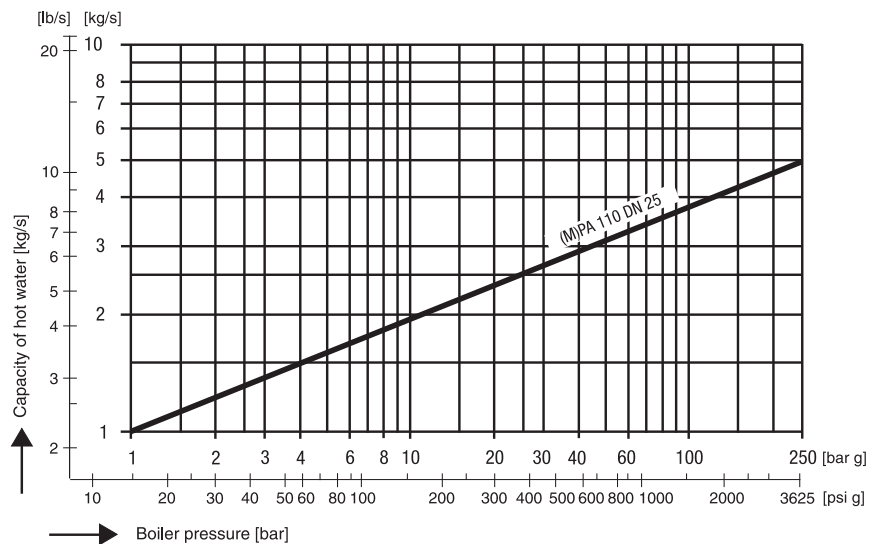
All inspection requirements have to be stated with the order. After supply of the equipment certification cannot be established. For tests and inspection charges please consult us.

Supply in accordance with our general terms of business.

### Chart 1



### Chart 2



## PED

The equipment meets the requirements of the Pressure Equipment Directive (PED) 97/23/EC. The equipment can be used for fluids of group 1 and 2.

With CE marking (apart from equipment in accordance with Article 3.3). For more information refer to our Declaration of Conformity with PED.

## ATEX

The equipment meets the requirements of the ATEX Directive 94/9/EC and can be used in potentially explosive zones 1, 2, 21, 22 (1999/92/EC). For more information refer to our Declaration of Conformity with ATEX.

## Flowserve GESTRA U.S.

2341 Ampere Drive  
 Louisville, KY 40299  
 Tel.: (502) 267-2205  
 Fax: (502) 266-5397  
 Email: fcd-gestra-usa@flowserve.com



GESTRA

## GESTRA Steam Systems

Product Range B1

### Oil Detector for Cooling Water Systems ORGS 11-2

### ORGS 11-2

#### Description

The oil detector/alarm ORGS 11-2 works according to the conductivity measurement principle. The electronic control unit of the ORGS 11-2 is an integral module of its terminal case and controls all functions – external switchgear is therefore **not** required.

A control and alarm unit should be added on downstream of the ORGS 11-2 in order to protect the installations to be cooled and prevent the possibility of oil leakage. The ORGS 11-2 has **two channels** for true fail safe confidence and features NC-type contact relays which will automatically signal alarm condition in the event of a malfunction or mains failure.

#### Design

The oil detector/alarm ORGS 11-2 consists of the following components:

**Measuring pot** for separating oil from water. The measuring pot can be isolated and features an automatically-operated quick-action air vent and a plug cock for draining and purging.

**Oil detector/alarm ORGS 11-1**, screwed into the measuring pot. The ORGS 11-2 is of the compact design type, consisting of a four-tip measuring electrode with integral alarm switch. The equipment works according to the level conductivity measurement principle, making use of two channels to detect any ingress of oil.

Use the oil detector/alarm e.g. for cooling water monitoring to detect ingress of oil.

#### Type approval

GL 17106-00 HH

When cooling water is used in marine installations for preheating or cooling oil or fuel, an oil detector, which will raise an alarm in the event of ingress of oil, is required according to Germanischer Lloyd.

#### Function

A water sample, taken downstream of the location at the highest point where ingress of oil might occur, is fed from below into a measuring pot (see schematic representations Fig. 2 and 3).

In the measuring pot the water-immiscible oil droplets precipitate and ascend, thereby forming an oil film which forces the water level to drop accordingly.

The lowering of the water level is detected by the electrode rods since the oil, which is non-conductive, interrupts the current flow between the two long and two short electrode rods. Two volt-free relay contacts in the terminal box evaluate the information and, if required, trigger an alarm and operate the associated switchgear. The amount of oil necessary to raise an alarm depends on the design of the measuring pot and the length of the electrode rods. The measuring pot is matched to the electrode such that an alarm is given when the oil content limit of approx. 50 ml is reached. The system can detect practically all insoluble, water-immiscible, non-emulsified matter with a lower density than water and a conductivity below the preset response sensitivity. Rust preventing oils which are for instance emulsified in cooling water will not trip an alarm.

#### Technical Data

##### Oil detector/alarm ORGS 11-2 with measuring pot

##### Admissible service pressure

6 barg (87 psig)

##### Admissible service temperature

110 °C (230 °F)

##### Flow velocity

100 – 300 l/h

##### Raising of alarm

Oil content limit: approx. 50 ml

##### Water inlet, draining

Ball valve, screwed connection E0 type 15-L

##### Water outlet

Ball valve, screwed connection E0 type 12-L/S

##### Weight

Approx. 7.4 kg

##### Electrode ORGS 11-1

##### Electrode

**Connection**  
Screwed 1" BSP (DIN ISO 228-1)

##### Material of wetted parts

Body: Austenitic S. S. X 6 CrNiMoTi 17 12 2 (DIN ref. 1.4571)  
Measuring electrode: Austenitic S. S. X 6 CrNiMoTi 17 12 2 (DIN ref. 1.4571)  
Electrode insulation: PTFE  
Ø of measuring electrodes: 5 mm

##### Terminal box

##### Housing

Terminal box with two lids  
Material: aluminium

##### Protection

IP 65 to DIN EN 60529

##### Admissible ambient temperature

70 °C

##### Cable entry

Cable glands with integral cable clamps  
2 x PG 9, 1 x PG 16

##### Mains supply

115/230 V ± 10 %, 50/60 Hz  
The transformer is of the split-bobbin type according to VDE 0551.

##### Special voltage

24 V ± 10 %, 50/60 Hz

##### Power consumption

5 VA

##### Fuse

Thermal fuse  $T_{max} = 102 °C$

##### Sensitivity

Range 1: 10 µS/cm  
Range 2: 0.5 µS/cm  
Code-switch selectable

##### Electrode voltage

10 V<sub>DC</sub>

##### Outputs for control circuit

Two volt-free relay contacts, contact material AgNi 0.15 hard gold plated.  
Max. contact rating with switching voltages of 24/115/230 V a.c.: 8 A resistive/inductive.  
Max. contact rating with a switching voltage of 24 V d.c.: 8 A

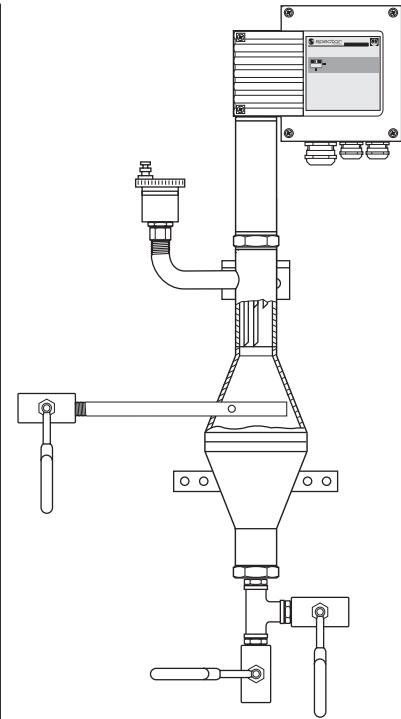


Fig. 1 ORGS 11-2

# Oil Detector for Cooling Water Systems ORGS 11-2

## Technical Data – continued –

**Energizing and de-energizing delays**  
3 seconds, factory set

### Indicators and adjustors

Two red LEDs to indicate "Electrode rod submerged" and "output relay energized"  
One four pole code switch for selection of sensitivity range

## Installation

The water sample taken from the cooling water cycle must flow continuously through the measuring pot (Fig. 2 and 3).

The sampling of the cooling water should take place downstream of the potential oil leakage location at the highest point and, if possible, in a horizontal line. The line leading to the measuring pot should be vertically ascending, running direct into the bottom part of the measuring pot. Avoid any narrow parts (< 1/2") since they could give rise to undesired emulsification of the oil. Air accumulated around the electrode will cause a malfunction alarm. Install an automatically operated quick-action air vent in the measuring pot in order to prevent the formation of air.

If space is a consideration and the measuring pot has to be installed at a lower point (see Fig. 3) make sure that the line leading to the measuring pot features sufficiently sized S-type bends in order to prevent emulsification. The discharge line does not have to meet specific requirements and can be installed at a right angle and DN 10 mm.

Insert the discharge line into the centre of the cooling water line in order to increase the suction effect which is a prerequisite for a continuous water sample flow through the measuring pot. To achieve a steady flowrate of approx. 200 l/h in the measuring pot reduce slightly the flow velocity in the cooling water line between the water sampling location and its re-entry point.

## Important Note

Cable required for wiring to the electrode: flexible, multi-conductor control cable, min. conductor size 1.5 mm<sup>2</sup>

## Order and Enquiry Specification

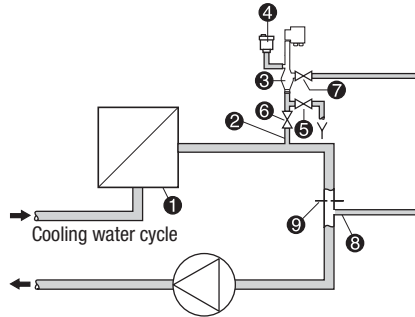
GESTRA Oil Detector/Alarm for cooling water  
ORGS 11-2, PN 6  
Mains supply

The following test certificates can be issued on request, at extra cost: In accordance with DIN EN 10204-2.1, -2.2 and -3.1 B.

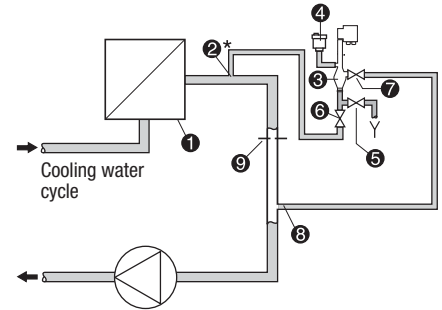
All inspection requirements have to be stated with the order. After supply of the equipment certification cannot be established. For tests and inspection charges please consult us.

Supply in accordance with our general terms of business.

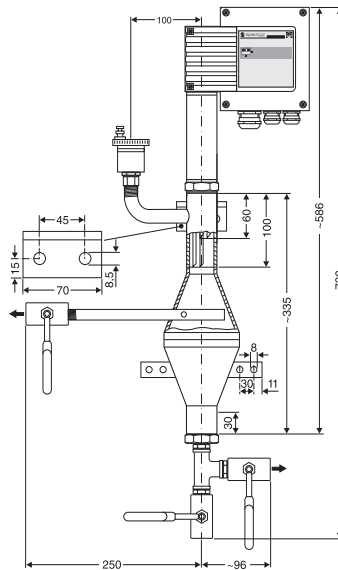
**Fig. 2** Example of an ideal measuring pot arrangement



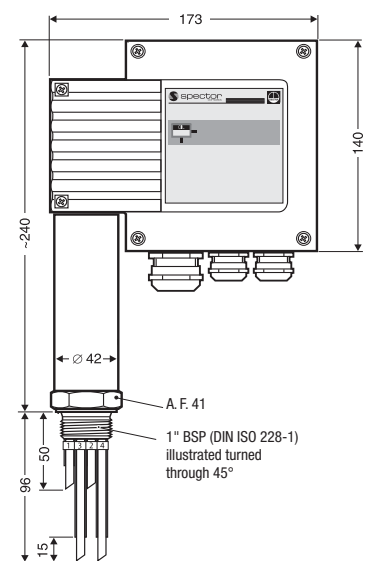
**Fig. 3** Example of a measuring pot arrangement at a lower point due to space limitations



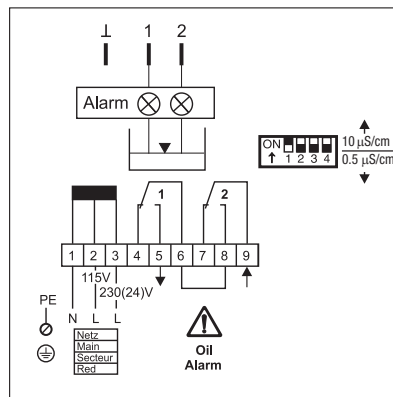
- 1 Preheater or cooler for oil or fuel. 2 Water sampling point (1/2") on top of the main line. The line leading to ORGS 11-2 should be as vertically ascending as possible, \* otherwise use five 1/2" S-type bends.
- 3 Measuring pot with oil detector/alarm. 4 Automatically operated quick-action air vent. 5 Drain valve.
- 6 Isolating valve for supply line. 7 Isolating valve for draining and purging. 8 Re-entry point of water sample, DN 10 mm. 9 Restrictor plate or throttle valve for generating a steady flowrate of 100 – 300 l/h or creating a differential pressure between valve 6 and 7 of approx. 0.1 bar.



**Fig. 4** Oil detector/alarm ORGS 11-2 with electrode type ORGS 11-1



**Fig. 6** Electrode type ORGS 11-1



**Fig. 5** Wiring diagram for the oil detector/alarm

# Flowserve GESTRA U.S.

2341 Ampere Drive  
Louisville, KY 40299  
Tel.: 001502 / 2672205, 001502 / 2672206  
Fax: 001502 / 2665397  
Email: dgoodwin@flowserve.com



GESTRA



## GESTRA Steam Systems

Product Range B1

Oil and Turbidity Detector TURBISCOPE®  
OR 52/5, OR 52/6

OR 52/5  
OR 52/6

### Description

The equipment combination ORG... and ORT 6 is designed for the continuous monitoring of transparent liquids to detect the ingress of insoluble light-scattering foreign matter. Measuring of turbidity and signal evaluation for indication, recording and control. Tripping of alarms, control valves etc.

The oil and turbidity detector OR 52/... consists of the measuring sensor ORG 12 or ORG 22 and the measuring transducer ORT 6.

### Typical Applications

- Steam boiler plants: Monitoring condensate returned to the boiler for contamination by oils and fats, in particular for boilers operating without constant supervision in accordance with TRD 604 sheet 1 (2 devices are required for 72 hrs. operation).
- Raw-water monitoring and water treatment: sand filters, demineralization plants, reverse osmosis plants.
- Design for Ex zone 1 available on request.
- Breweries and the beverage industry: filtration, monitoring of wort, quality assurance etc.
- Marine application: 15 ppm oil content alarm for oil/water separators on ships in accordance with IMO (International Maritime Organization) and EC Directive 96/98/eec (MED); for raw water monitoring and water treatment installations.

### Design

The GESTRA TURBISCOPE consists of a measuring sensor and a measuring transducer:

#### Measuring Sensor ORG...

The sensor is a photometric measuring device with separate light emitter and light receiver and a glass cylinder serving as sightglass. The sensor is provided with two connections for the inlet and outlet of the liquid to be monitored (with flow reversal) and one connection for the discharge of the rinsing water or for sampling. The upper and lower cover flanges can be interchanged and turned through 90° or 180°. It is possible to clean the inside of the glass cylinder during operation with the aid of the cleaning plunger.

Two different designs are available:

- ORG 12: Grey cast iron GG-25
- ORG 22: Stainless steel 1.4580

#### Measuring Transducer ORT 6

The measuring transducer ORT 6 is located in a field case for wall installation. The cover of the case is provided with the indicators and operating buttons as well as a seven-segment display indicating the measured values and LEDs for signalling alarm condition or malfunction.

### Function

The GESTRA TURBISCOPE is a continuous measuring device of turbidity as produced by foreign matter that is not dissolved in transparent liquids. The system operates on the Tyndall effect (concerning the scattering of light by suspended particles) which provides a high sensitivity of measurement for emulsified oils and greases and other suspended particles.

The light emitted by the light emitter of the sensor is focused by diaphragms fitted in the tube of the light emitter. The light beam penetrates through the glass cylinder into the liquid to be monitored where it is divided into a beam which passes through the liquid and a beam scattered at the foreign particles whose light intensity depends on the concentration of the foreign particles. The light intensity is transformed by a photo-electric cell in the light receiver into a proportional electric current fed to the measuring transducer which determines the concentration of foreign particles.

The light beam passing through the liquid is received by a second photo-electric cell. If the light intensity received deviates from a reference value in the measuring transducer the light intensity of the light emitter is correspondingly readjusted. Extinction and lamp aging are thus compensated. If the deviation can no longer be compensated, for example, because of breaking of lamp filament, heavy contamination of glass cylinder or excessive turbidity, a switch in the measuring transducer immediately de-energizes a relay. Simultaneously the LED MALFUNCTION lights up and the output current returns to zero.

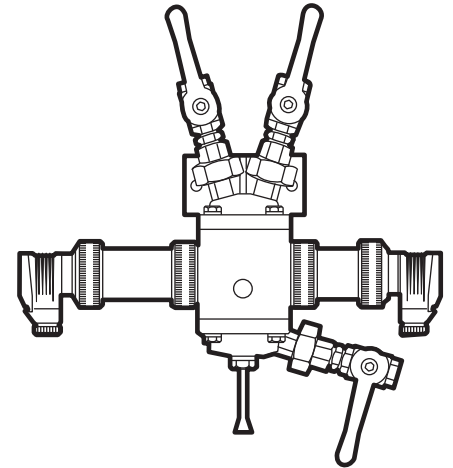
Zero point and measuring range can be adjusted on the measuring transducer. The zero-point adjuster (0 %) is used to compensate stray light (reference fluid) which might vary from sensor to sensor. The 100 % adjuster permits the calibration of the measuring range to the specific turbidity of the plant (see also under "Important Notes").

#### Measuring Transducer ORT 6

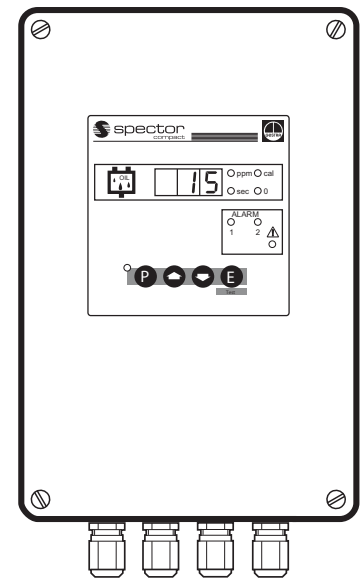
This equipment serves as transmitter for measuring and control purposes. A stabilized output current of 4 to 20 mA is provided at the output. The switchpoints are continuously adjustable over the complete measuring range of 0 to 15 ppm. If the scattered light or the turbidity value exceeds the switchpoint, the output relay is de-energized after a preset time lag (time delay adjustable between 0 to 20 sec.)

Malfunction causes the immediate de-energizing of the limit value relay and is indicated by the lighting-up of a yellow LED.

The readings are indicated on the digital seven-segment display unit.



Measuring sensor ORG 12, ORG 22



Measuring Transducer ORT 6

## Technical Data ORT 6

### Wiring

8 cable glands with integral cable clamps, M 16 x 1.5  
Screw-type terminal strips with wire guard, max.  
conductor size 1.5 mm<sup>2</sup>

### Mains voltage

230 V + 10 / - 15 %, 50 - 60 Hz  
115 V + 10 / - 15 %, 50 - 60 Hz (optional)  
For nominal voltage rating see name plate

### Fuse

Thermal fuse (semi-delay) 0.2 A

### Power consumption

25 VA

### Measured quantity

Turbidity (ppm = parts per million)

### Measuring range

0 - 15 ppm (cf. name plate)

### Lamp voltage for sight emitter

No-load voltage: 14 V  
with light emitter connected: < 12 V AC, 10 W

### Actual value output

0/4 - 20 mA

### Bus Networking

CANopen (optional)

### Load

Load 0 to 500 Ω

### Output

3 volt-free change-over contacts  
Max. contact rating for switching voltages  
24/115/230 V: 4 A

### Switchpoints

Continuously adjustable over the whole measuring  
range. Other measuring ranges available on request.

### Time delays

Adjustable between 0 and 20 sec.  
Other time delays available on request.

### Indicators and adjusters

4 push buttons for programming one red LED  
"Alarm 1", one red LED "Alarm 2", one yellow LED  
"Malfunction", one yellow LED "Program status",  
one 7-segment display for three digits

### Protection

IP 65 to EN 60529

### Admissible ambient temperature

0 - 55 °C

### Housing material

Die-cast aluminium, "GESTRA blue", RAL 5002

### Approx. weight

3.6 kg

## Technical Data ORG ...

### Type approvals

- GL (Germanischer Lloyd) for condensate monitoring on ships
- TÜV type approvals for condensate monitoring (land installations), based on WÜ 100
- Type approved by SEE-BG as 15 ppm content alarm in accordance with IMO (bilge-oil)
- EC type approved by SEE BG in accordance with EC Directive 96/98/EC (MED)

### Nominal size

DN 10, connection 3/8" BSP to EN ISO 228-1

### Nominal pressure

PN 10

### Flowrate

0.5 to 50 l/min

### Pressure drop

At a flowrate of 2 l/min and V-shaped flow through the sensor with a pipe length of 1 m (DN 10) and 4 bends; approx. 5 mbar ( $\zeta = 6.1$ ).

### Fluids

Water, condensate, drinks etc.

### pH values

Up to 10.5 (a pH value of 11 and above will lead to wear of the glass, depending on the temperature).

### Fluid temperature ranges

0 ... 60 °C with drying cartridge,  
60 ... 120 °C with vent nipple.

### Protection

IP 65

### Max. ambient temperature

60 °C

### Light emitter

Glow lamp 12 V / 10 W BA 15 s  
cable connection via 4 pole connector

### Light receiver

Two silicon photo-electric cells,  
cable connection via 4 pole connector

### Approx. weight

6.8 kg

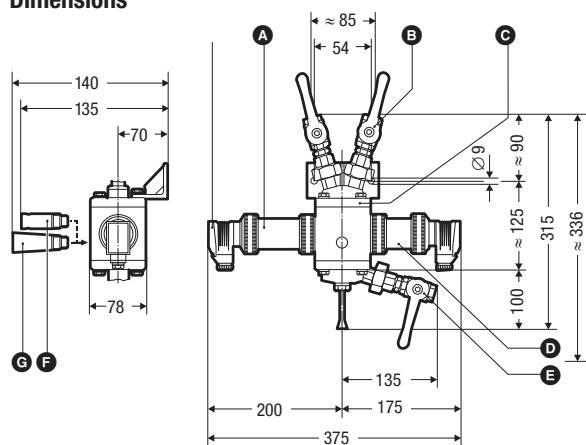
### Materials

	ORG 12	ORG 22
Housing cover	Grey cast iron GG-25	1.4580
Wetted parts	0.6025 galvanized	1.4580
Ball valves	Brass 58	1.4436
Screwed unions	St	1.4571
Glass cylinder	Duran 50	Duran 50
O-rings	EPDM	EPDM
Housing	0.6025 galvanized	0.6025 galvanized
Cleaning disc	EPDM	EPDM

## Scope of supply

Items	OR 52/5	OR 52/6	Stock code (230 V)	Stock code (115 V)
Measuring transducer	ORT 6	ORT 6	392 099	392 106
Measuring sensor incl.	ORG 12	ORG 22	385 193	385 195
Ball valves	3	3	077 135	077 135
Screwed unions	3	3	077 133	077 133
Drying cartridge (supplied but not fitted)	1	1	077 139	077 139
Vent nipple (screwed in)	1	1	077 213	077 213
Turbidity standard 20 ppm (supplied)	1	1	387 369	387 369

## Dimensions



Measuring sensor ORG 12, ORG 22

- A** Light emitter with tube (can be interchanged with **D**)
- B** 3/8" EN ISO 228-1
- C** Upper flange with two connections can be interchanged with lower flange
- D** Light receiver with tube (can be interchanged with **A**)
- E** 3/8" EN ISO 228-1
- F** Vent nipple
- G** Drying cartridge
- H** Cable clamp M 16 x 1.5
- I** Body made of die-cast aluminium

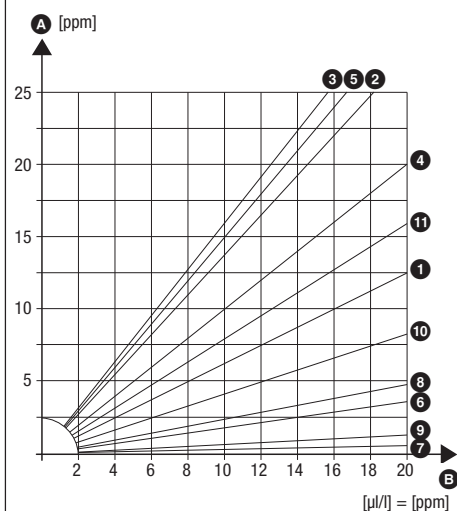
## Turbidity Curves

A light beam shines through the liquid and any foreign matter which is not dissolved scatters the beam. The scattered light intensity increases in proportion to the concentration of suspended particles, the degree of turbidity depending on:

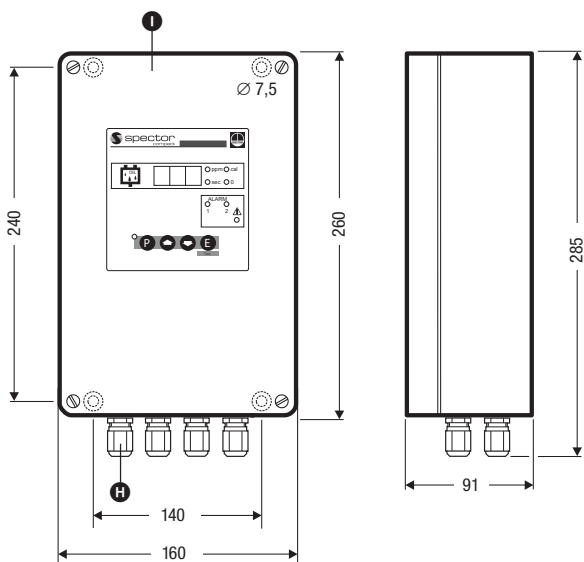
1. size of the particles (degree of emulsification)
2. shape and composition of the particles
3. optical properties of the particles.

In the case of oils, fats and greases the degree of emulsification is a decisive factor.

These influences have been considered in the following chart:



- A** Indication
- B** Concentration
- 1** Fuel oil "EL" at 15 °C, coarse emulsification
- 2** Fuel oil "EL" at 15 °C, fine emulsification
- 3** Fuel oil "EL" at 80 °C, fine emulsification
- 4** Engine oil "SAE 15W40" at 15 °C, fine emulsification
- 5** Vegetable oil at 15 °C, fine emulsification
- 6** Xylene at 20 °C, fine emulsification
- 7** Xylene at 80 °C, fine emulsification
- 8** Red-berry juice, concentrated
- 9** Black-berry juice, concentrated
- 10** Skimmed milk, fat content 0.1 %, referred to fat concentration
- 11** Turbine oil "T 68", gearbox oil "M 68"



Measuring transducer ORT 6 (field case for wall installation)

# Oil and Turbidity Detector TURBISCOPE® OR 52/5, OR 52/6

## Important Notes

### Condensate Monitoring

Condensate monitoring is recommended upstream of condensate tanks, in particular in steam boiler plants operating in accordance with TRD 604 / EN 12953, part 6. Readings are influenced by live steam and flash steam. Care should therefore be taken that the sensor does not come into contact with steam. For more information see Installation Manual OR.

### Connecting Three-Way Valve

For condensate and bilge-water monitoring a three-way valve should be controlled via alarm contacts such that contaminated condensate is discharged if the turbidity is too high (ingress of oil or start-up contamination).

Valves with a single-phase a.c. motor can be directly connected, max. power 50 VA. If three-phase actuators are used a reversing contactor has to be inserted. Valves with pneumatic actuators can be triggered via solenoid valves.

## Wiring

- Light emitting device with screened two-core cable (e.g. LYIC 2 x 0.75 mm<sup>2</sup>, max. length 50 m)
- Light receiving device with screened four-core cable (e.g. LYIC 4 x 0.5 mm<sup>2</sup>, max. length 50 m)

## Order and Enquiry Specifications

GESTRA Oil and Turbidity Detector TURBISCOPE, consisting of measuring sensor and transducer

- GESTRA oil and turbidity detector OR 52/5, consisting of measuring sensor ORG 12 (grey cast iron GG-25) and measuring transducer ORT 6
- GESTRA oil and turbidity detector OR 52/6, consisting of measuring sensor ORG 22 (stainless steel) and measuring transducer ORT 6

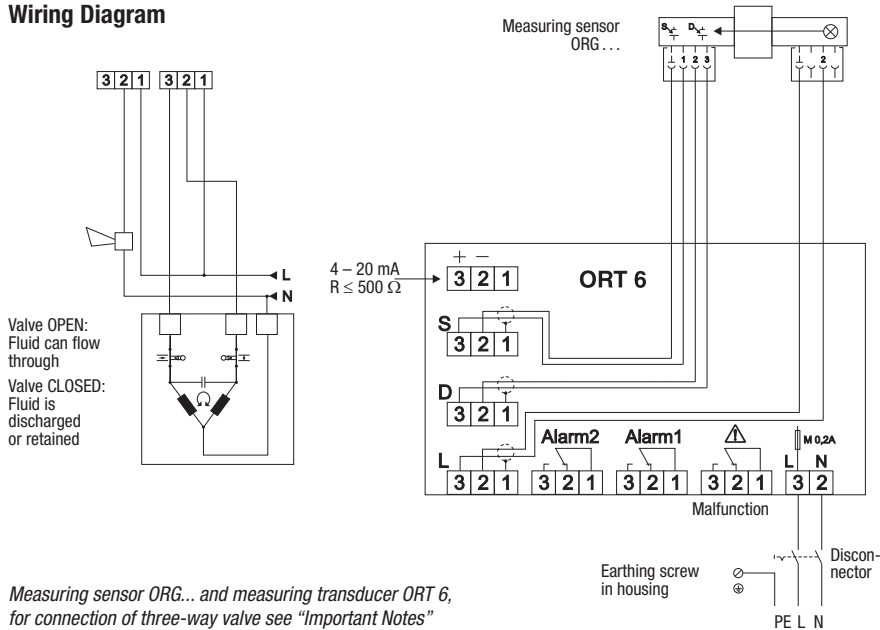
Supply voltage .....V (230 V or 115 V)

## Ancillary Units

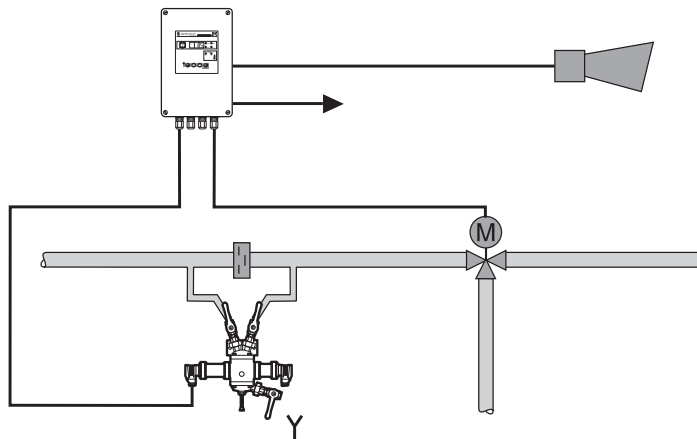
- Three-way valve
  - motorized, series 200
  - pneumatic, series 500
  - with three-way solenoid valve
- Stop valve GAV
- DISCO non-return valve type RK...

Supply in accordance with our general terms of business.

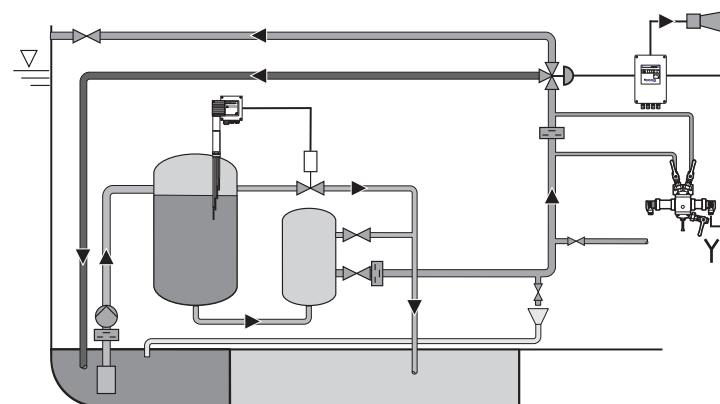
## Wiring Diagram



## Typical example of condensate monitoring, water treatment, filtering etc.



## Typical example of 15 ppm oil content alarm in acc. with IMO



# Flowserve GESTRA U.S.

2341 Ampere Drive  
Louisville, KY 40299  
Tel.: 001502 / 2672205, 001502 / 2672206  
Fax: 001502 / 2665397  
Email: dgoodwin@flowserve.com



GESTRA

## GESTRA Steam Systems

Product Range B

### Self-Tuning Universal Controller KS 92-1

### KS 92-1

#### Description

The universal controller is suitable for single closed-loop control systems and for automating industrial processes. The equipment is highly flexible and an economical and efficient solution for many industrial applications. The controller is self tuning during start-up and to the setpoint. An optional serial interface RS 422/485 is also available. The configuration and parameterization data are stored in an EEPROM. The user-friendly three-line alphanumeric "day & night" display enables convenient menu-driven operation on site of the controller by entering the configuration and parameter settings in accordance with the existing operating conditions and requirements.

#### Function

##### Continuous controller

PID controller  
Proportional band  $X_p$ : 1 to 9999  
Integral time  $T_i$  [s]: 0.1 to 9999 s  
Derivative time  $T_d$  [s]: 0.1 to 9999 s

##### Switching controller

2 position (on-off) or 3 position stepping controller  
The universal controller KS 92-1 is self optimizing, which means that the equipment itself tunes the optimum control parameters to the setpoint.

#### Design

Controller case in accordance with DIN 43700 for panel mounting and installation in control cabinets.  
Wiring via screw-type terminals on back of housing.  
For conductor cross-section from 0.5 to 2.5 mm<sup>2</sup>.

#### Technical Data

##### Inputs

##### Controller input 1

##### Thermocouples

Type	°C range
B	0/1820
C	0/2315
D	0/2315
E	-100/1000
L	-100/900
J	-100/1200
K	-100/1350
N	-100/1300
R	0/1760
S	0/1760
T	-200/400

Internal temperature compensation

Max. additional error:  $\pm 0.5$  K

Input impedance:  $\geq 1$  k $\Omega$

Sensor break detection indicated on display, output of a safety value or detection of control output

##### Voltage / Current

	Direct voltage	Direct current
Input resistance	110 k $\Omega$	20 $\Omega$ DIN IEC 381
Range	0 – 10 V	0 – 20 mA

##### Pt 100

For Pt 100 sensors to DIN 43760 and for three-wire connections

Measuring range:  $-200$  °C up to  $850$  °C

Measured current: max. 0.2 mA

Display error:  $\leq 1$  K

Monitoring for break in sensor or short circuit with indication on display, output of a safety value

Lead resistance: max. 30  $\Omega$ / lead

##### Logic input

2 logic inputs via volt-free contacts.

Configurable for the following functions:

interlocking operation, immobilisation of manual button, resetting saved alarms, switching to external setpoint, manual operation

##### Controller input 2

Heating current, external setpoint, position feedback, second actual value

##### Setpoint

1 internal and 1 external setpoint: mA or V

Function: fixed setpoint controller or fixed setpoint follow-up controller

##### Front interface

Connection at the front of the equipment via PC adaptor cable (optional). Thanks to the BlueControl software the KS 92-1 can be configured, parameterized, commissioned and operated manually.

##### Output

##### Relays

2 volt-free changeover contacts, output 1 and 2, switching capacity: 250 V, 2 A, resistive, 500 VA  
Servomotor, output 3 and 4, switching capacity 250 V, 2 A, resistive, 500 VA

##### Note

When connecting inductive loads, e. g. control contactors, make sure that the contactors are provided with RC suppressor circuits according to the specification of the manufacturers of the contactors in order to prevent high voltage spikes.

##### Current

0/4 – 20 mA max. load  $\leq 500$   $\Omega$ , output 4

##### Voltage

0/2 – 10 V configurable, load  $\geq 2$  k $\Omega$ , output 4

##### Alarm / Limit values

2 volt-free changeover contacts for upper and lower limit (absolute band and deviation alarm) with adjustable hysteresis

Switching capacity: 250 V, 2 A, resistive

##### Transmitter supply

18 V DC  $\pm 20$  %, not insulated

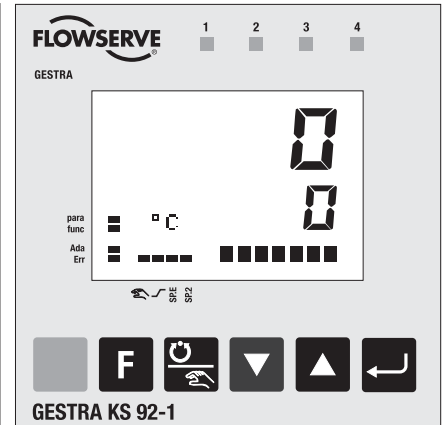
max. current 22 mA, max. load 600  $\Omega$

##### Display

LED display: alphanumeric, three-lines "day & night" display, showing process values numerically or as a bar graph, with additional elements

##### Settings

Configuration, parameterization and operation via keyboard, menu-driven.



P. T. O.

# Self-Tuning Universal Controller KS 92-1

## Technical Data – continued –

### Housing

Panel mounting  
Dimensions: 96 x 96 x 120 mm  
Weight: 300 g  
Protection: IP 65 (front panel)  
IP 20 (back)

### Wiring

Interfaces: RS 422/485  
Voltage supply of measuring transducer: 24 V DC  
Max. admissible current: 22 mA

### Mains voltage

Voltage range: 90 – 260 V AC, 48 – 62 Hz;  
24 V AC/DC (optional)  
Power consumption: 8 VA  
Admissible ambient temperature: 0 °C – 60 °C  
Storage temperature: –40 °C to 70 °C  
Rel. humidity: ≤ 75 % of annual average, must not be exposed to dew

## Important Note

Measuring sensors should always be connected with screened lines. If a pneumatic actuator is to be installed make sure that an I/P transducer is provided.

Ensure interference suppression by providing the loads connected to the relay contacts with suitable RC combinations.

## Order & Enquiry Specification

Microprocessor universal controller

### Type KS 92-1

With min. and max. limits  
Case for panel mounting  
Installation dimensions: 96 x 96 x 120 mm  
Protection: IP 65, front panel

### Measuring inputs:

Pt 100 (three-wire)  
Thermocouples (11 types)  
External setpoint 0/4 – 20 mA  
2 logic inputs, digital contacts  
1 internal/external setpoint each

### Outputs:

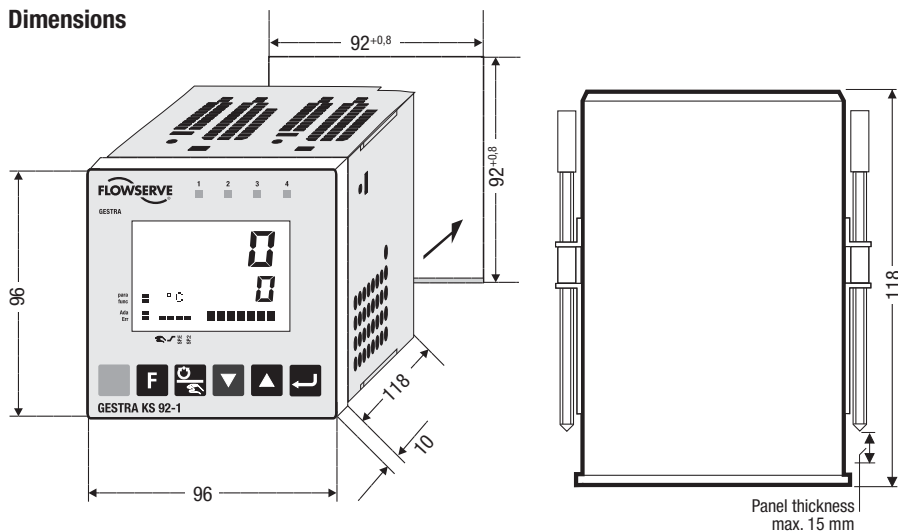
Voltage supply of transmitter: 24 V DC  
Servomotor (output 3 and 4)  
Control output or actual value 0/4 – 20 mA (output 4)  
2 isolated optocouplers (output 5, 6)  
2 changeover contacts min./max. (output 1 and 2)  
Supply voltage: 90 – 260 V AC, 48 – 52 Hz

## Ancillary Equipment

- Thermocouples TRG 5-11, TRG 5-41
- Resistance thermometer TRG 5-55 to TRG 5-67
- Pressure transducer DRT, CK/DC
- Level electrode NRG 26-...
- Level transmitter NRT 2-1
- Conductivity transmitter LRT 1-5/LRT 1-6
- Pneumatic and electric control valves series 200, 500, V 725, V 726 and V 727

Supply in accordance with our general terms of business.

## Dimensions



## Wiring Diagram

Typ: KS92-112-1000D-084  
Ident: 622123456 1234  
Vers.: 3.6  
Sach-Nr. Date: 0516



392222

GESTRA AG, Münchener Str.77, D-28215 Bremen

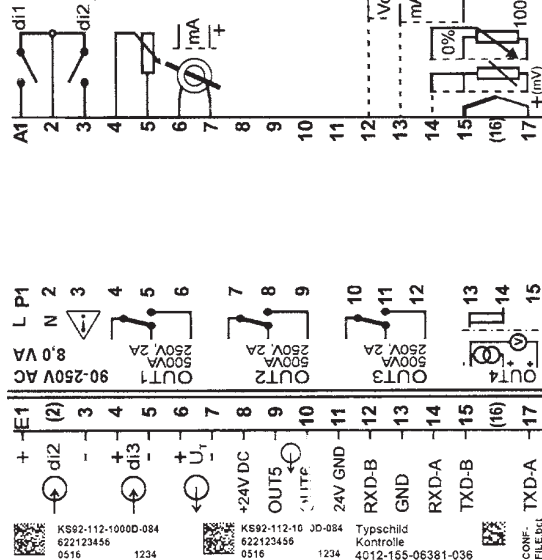
**KS92-112-1000D-084**

Typ: KS92-112-1000D-084  
Ident: 622123456 1234  
Vers.: 3.6  
Sach-Nr. Date: 0516



392222

GESTRA AG, Münchener Str.77, D-28215 Bremen



## ATEX (Atmosphère Explosible)

According to the European Directive 94/9/EC the equipment must not be used in potentially explosive atmospheres.

# Flowserve GESTRA U.S.

2341 Ampere Drive  
Louisville, KY 40299  
Tel.: (502) 267-2205  
Fax: (502) 266-5397  
Email: fcd-gestra-usa@flowserve.com



GESTRA

## GESTRA Steam Systems

Product Range B2

### Cycling Timer PRS 9

### PRS 9

#### Description

The PRS 9 is an analogue/digital cycling timer. In combination with up to four level switches type NRS 2-4 and a position-controlled limit switch the cycling timer can be used as part of a controlled draining system in a power station.

Use cycling timer PRS 9 only in combination with GESTRA level switch NRS 2-4.

#### Function

Signals coming to the inputs of the level switches and the position-controlled limit switch will be processed electronically, with the time delay adjusted in the equipment being taken into account. Dependent on the adjustment the drain valve will be controlled in one or two steps with a time delay.

#### Design

##### Design "c"

19" slide-in unit with guide rails and 32pole screw-type connector for installation in 19" magazine acc. to DIN 41494, part 5.

##### Design "d"

19" spare slide-in unit

#### Technical data

##### Supply voltage

24 V DC

##### Power consumption

4 VA

##### Input

Three control inputs (volt-free relay contacts)  
Control voltage 12 V DC

##### Output

2 volt-free relay contacts

Max. contact rating with a switching voltage of 24 V, 115 V and 230 V AC: 4 A resistive, 0.75 A inductive at  $\cos \varphi 0.5$ .

Max. contact rating with a switching voltage of 24 V DC: 4 A.

Service life of the relays:  $30 \times 10^6$  switching cycles.

##### Indicators and adjustors

1 green LED "OPERATING", 1 red LED "VALVE OPEN",

1 red LED "VALVE CLOSED".

1 pushbutton "TEST" (simulating alarm signalled by P1)

1 switch (on the circuit board) for program selection,

1 switch (on the circuit board) for time delay setting

##### Protection

IP 10 to DIN 40050

##### Admissible ambient temperature

0 °C to +70 °C

##### Case

19" slide-in unit with front panel to DIN 41494 part 5 and rear 32 way Euro card connector to DIN 41612 for installation onto 19" magazine.

Front panel: Aluminium

##### Wiring

via 32 pole screw-type connector at the back of the 19" magazine, max. conductor size 1.5 mm<sup>2</sup>

##### Weight

approx. 0.6 kg

#### Scope of supply

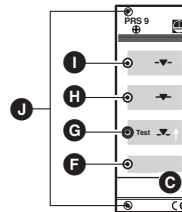
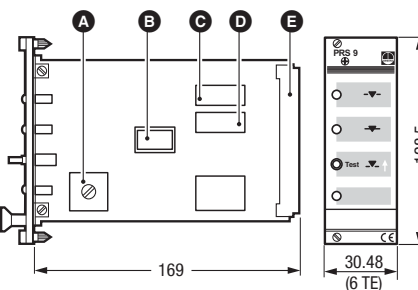
##### PRS 9, design "c"

- 1 Cycling timer type PRS 9
- 2 Guide rails
- 1 32 pole screw-type connector
- 1 Installation instructions

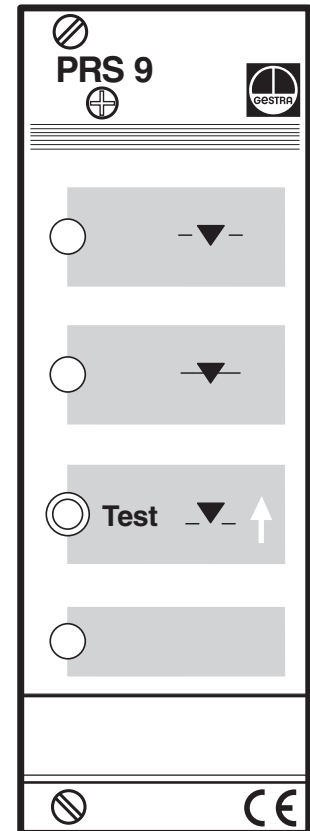
##### PRS 9, design "d"

- 1 Cycling timer type PRS 9
- 1 Installation instructions

#### Dimensions



- A** Switch S1 "TIME DELAY"
- B** Switch S2 "PROGRAM SELECTION"
- C** Relay 2 "ENERGIZED"
- D** Relay 1 "DE-ENERGIZED"
- E** 32 way Euro card connector
- F** LED "OPERATING"
- G** Push button "TEST"
- H** LED "VALVE CLOSED"
- I** LED "VALVE OPEN"
- J** Fixing screws



Cycling timer PRS 9

# Cycling Timer PRS 9

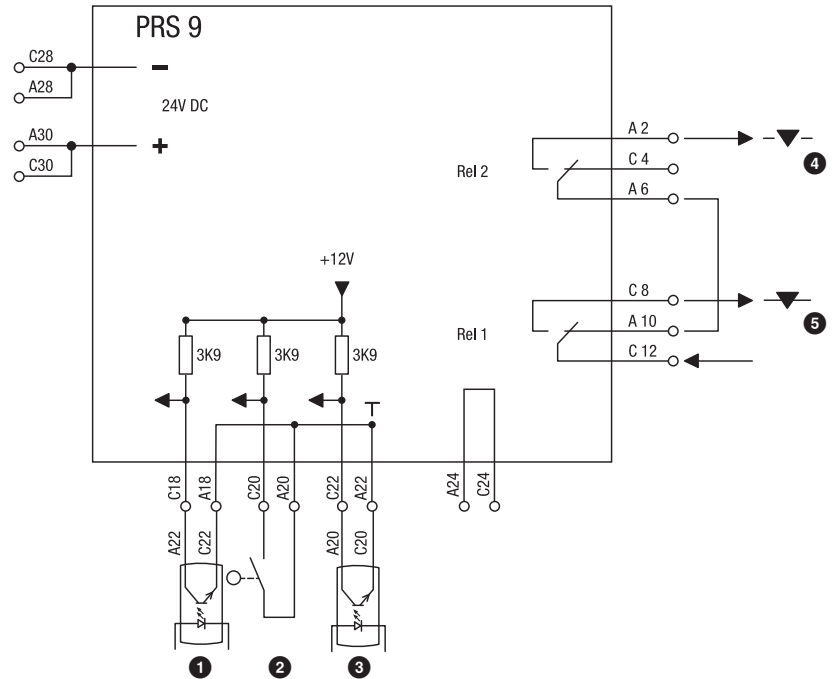
## Installation

### Design "c"/"d"

- Install the guide rails and the screw-type connector in the 19" magazine.
- Introduce the 19" slide-in unit onto the guide rails until it hits the stop.
- Tighten the fixing screws ①.

## Wiring diagram

### Design "c"/"d"



- ① P2 Level switch NRS 2-4 (level electrode 2)
- ② Position-controlled limit switch of the drain valve
- ③ P1 Level switch NRS 2-4 (level electrode 1)
- ④ Rel 2 for opening the drain valve
- ⑤ Rel 1 for closing the drain valve

Supply in accordance with our general terms of business.

## Flowserve GESTRA U.S.

2341 Ampere Drive  
Louisville, KY 40299  
Tel.: 001502 / 2672205, 001502 / 2672206  
Fax: 001502 / 2665397  
Email: dgoodwin@flowserve.com





# GESTRA Steam Systems

## Product Range B

### Logic Unit SRL 63-a

### SRL 63-a

#### Description

For the installation of low-level limiters of “high-integrity design” in measuring pots mounted outside of the boiler, it is imperative that the periodic purging of the connecting lines to the boiler be monitored properly.

To achieve this, the connecting lines are shut off one after the other at defined intervals and the measuring pot is drained.

The logic unit SRL 63 monitors compliance with the preset times and the sequence of valve operations; in addition, it bypasses the low-level limiter to ensure that the system is not shut down during purging.

The logic unit for monitoring the purging cycle consists of a compact PLC, a safety time-lag relay and a coupling relay. The design complies with prEN 50156.

#### Function

The logic unit monitors the following times:

- **Interval time:** This is the time interval at which, depending on the mode (24h / 72h operation), the connecting lines have to be purged.
- **Standby period:** The purging process must be initiated during this time. The standby period begins when the interval time has elapsed.
- **Purging time:** During this period, the purging process must be performed through actuation of the valves. Actuation of the valves is signalled by means of the limit switches; similarly, when the electrode of the low-level limiter is exposed, this is sensed through the output contact of the corresponding level switch. If a signal is not received within the purging time, the safety circuit is opened. Since a low-level limiter may be bypassed for a maximum of 5 minutes, monitoring of the purging time is a safety-relevant function.

The interval time is started when the logic unit is switched on. The display of the PLC shows the full hours of the remaining time. This can be synchronized at any time by closing an interconnection valve (E or D), i.e. the purging time begins and the interval time is reset to its initial value (e.g. 24h, 72h etc.).

During operation, the standby period is started at the end of the interval time, which is immediately reset to its initial value (e.g. 24h, 72h etc.). The PLC then starts the purging time when an interconnection valve (E or D) leaves the end position “Open”.

The safety circuit is opened when the standby time or the purging time is exceeded, and it is only closed again when the purging process has been completed properly.

During the purging time, the output contact of the low level limiter is bypassed. This bypass is triggered by the undelayed contact of the safety time-lag relay and limited to 5 minutes by the delayed contact of this relay.

Once all valves signal that they have reached their initial positions and the level switch of the low-level limiter senses that the level electrode is exposed, the purging process has ended and the bypassing of the low-level limiter is terminated.

In the event that the mains supply fails during the purging time, the bypassing of the low-level limiter is cancelled and the safety circuit is opened. If the mains supply is switched on again, the bypass remains deactivated and the safety circuit is only closed again after the purging process has been completed properly.

Expiry of the purging time and standby period, as well as deactivation of the safety circuit, are indicated by means of pilot lamps.

#### Design

##### SRL 63-a

Logic unit SRL 63-a with 3 LEDs and a compact PLC, for wall mounting, with clear lid. 5 cable glands for connecting wires.

External dimensions: 295 x 281 x 168.2 mm

#### Technical Data

##### Inputs

- 5 volt-free contacts from the limit switches of the valves
- 1 volt-free contact from a second SRL which may be mounted at the same boiler (interlock)
- 1 volt-free contact from the low-level limiter

##### Outputs

- 2 volt-free change-over contacts each for bypassing/deactivating the safety circuit
- Thermal current  $I_{th}$  : 4A, switching capacity acc. to AC-15: 3 A / 230 V a.c.
- 1 volt-free change-over contact as a signalling contact for a second logic unit
- Contactors must be interference-suppressed as per manufacturer’s instructions (RC combination)
- 3 contacts for internal or external indication of status (pilot lamps)

##### Interval time

Adjusted at our works within the range 2 to 336 hours, in compliance with TRD 24/72h

##### Standby period

Adjusted at our works within the range 15 minutes to 2 hours, in compliance with TRD 1h

##### Purging time

Set at our works to 5 minutes

##### Indicators and adjustors

- 1 control panel at the PLC for triggering a test
- 3 pilot lamps for standby period / purging time, bypassing of the low-level limiter and deactivation of the safety circuit

##### Mains voltage

230 V +10/-15 %, 50 - 60 Hz

##### Voltage of the safety circuit

230 V, 50 - 60 Hz, optional 24 V, 50 - 60 Hz

##### Power consumption

26 W

##### Protection

Enclosure: IP 65 to EN 60529

##### Permissible ambient temperature

Maximum 55 °C

##### Case

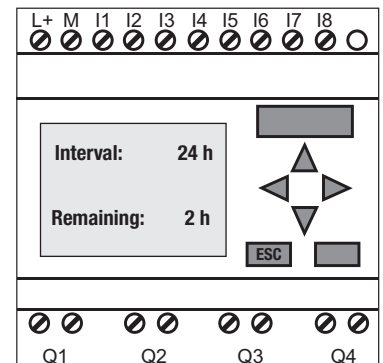
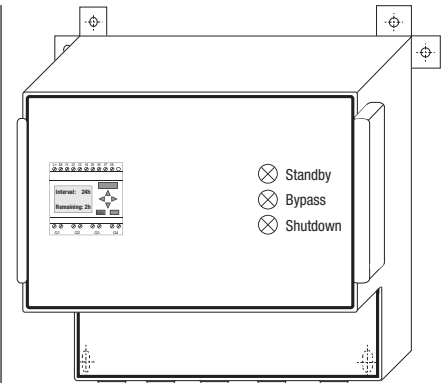
Field case for wall mounting, with clear lid  
Case material: Polystyrene/polycarbonate, colour light gray

##### Cable entry / electrical connection

5 cable glands, M16, electrical connection via two terminal strips

##### Weight

Approx. 3.3 kg



# Logic Unit SRL 63-a

### Please note:

If both low-level limiter electrodes of a boiler are installed in external measuring pots, simultaneous purging and bypassing of the low-level limiters is not admissible.

To prevent this happening, the two logic units **must** be interlocked by means of parallel connections between the terminals 16 to 20 of either unit.

For connecting the limit switch, we recommend a control cable, e.g. Ölflex 110 H, 7x1 mm<sup>2</sup>, length max. 100 m. To protect the relay contacts, fit the safety circuit with a fuse T 2.5 A (slow-blow) or 1 A (TRD 604, 72h operation).

### Order & Enquiry Specification

GESTRA Logic Unit SRL 63-a

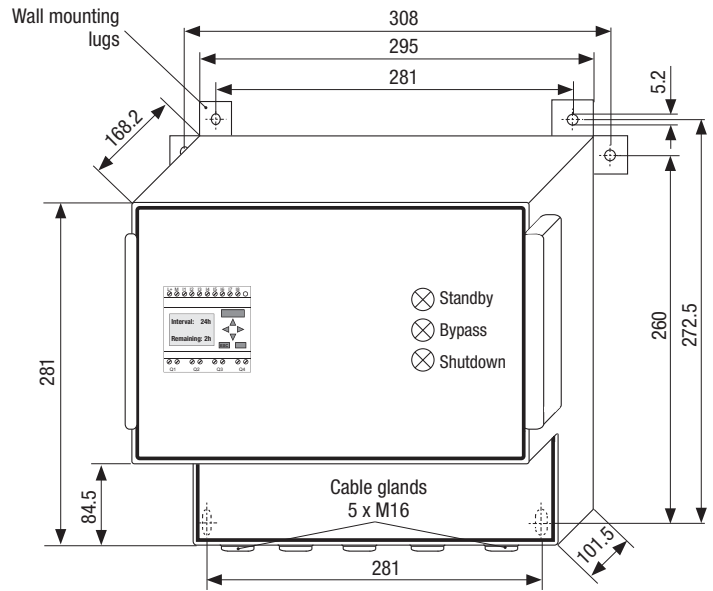
Interval time..... h  
Purging time ..... min  
Voltage of the safety circuit ..... V

### Ancillary Units

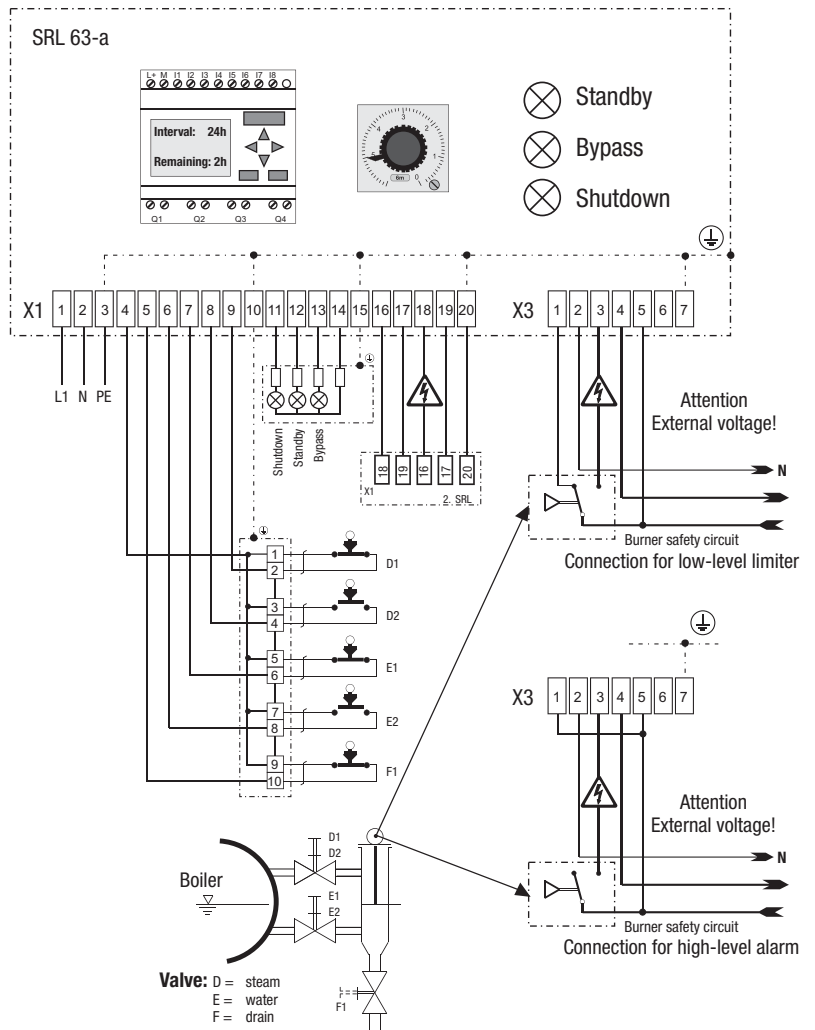
- High-integrity self-monitoring level limiter with control unit NRS 1-7 / NRS 1-9 and level electrode NRG 1x-11 / NRG 16-36
- High-integrity self-monitoring high level alarm with control unit NRS 1-8 and level electrode NRS 1x-12
- Measuring pot MFxxxx for level electrodes
- Two shut-off valves GAVxxx-II
- One drain valve GAVxxx-I

Supply in accordance with our general terms of business.

### Dimensions



### Wiring diagram



## Flowserve GESTRA U.S.

2341 Ampere Drive  
Louisville, KY 40299  
Tel.: (502) 267-2205  
Fax: (502) 266-5397  
Email: fcd-gestra-usa@flowserve.com



GESTRA

## GESTRA Steam Systems

### Programme-Controlled Blowdown System

#### TA 5, TA 6

#### Description

Generation of periodic pulses to initiate a blowdown cycle via the GESTRA rapid-action intermittent blowdown valve type MPA, i.e. automation of intermittent boiler blowdown.

The equipment meets the German regulations for use in steam boiler plants operating without constant supervision or with limited supervision (TRD 602 and TRD 604).

#### Design

The programme-controlled blowdown system consists of an electric cycling timer, a three-way solenoid valve and a strainer for either compressed air or water.

The following designs are available:

##### TA 5

Cycling timer type PRS 7-b, ¼" three-way solenoid valve and ½" strainer supplied separately.

##### TA 6

As TA 5, however, all component parts assembled and interconnected on a mounting panel. The cycling timer type PRS-7b is protected by a sheet-steel case against dust and water jets.

#### Operation

The cycling timer type PRS-7b generates a control pulse which, after the preset blowdown interval, operates the three-way solenoid valve. This in turn actuates the rapid-action blowdown valve by means of compressed air or pressurized water and closes it again at the end of the pulse (blowdown) duration.

The blowdown intervals can be adjusted.

A push-button manual override is provided on the cycling timer type PRS-7b. A single push will initiate a blowdown cycle. The next automatic cycle is then carried out after the adjusted interval.

The push button allows a test of the blowdown system at any time as required by the regulations in force.

For test purposes and in the event of a mains failure the three-way solenoid valve can be operated by hand. The strainer is used to remove any dirt or rust particles from the compressed air or pressurized water.

#### Technical Data

##### Cycling Timer PRS-7b

##### Interval time T (blowdown interval)

Adjustable in steps of 0.5 h within a range of 0.5 h...31.5 h

##### Pulse duration t (blowdown duration)

Adjustable in steps of 1 s within a range of 1 s...63 s

##### Output

1 potential-free relay contact:  
max. contact rating: 250 V, 500 W, 3 A ohmic with a life of  $4 \times 10^5$  switching cycles or 0.35 A inductive with a life of  $2 \times 10^6$  cycles; contact material silver, hard-gold plated

##### Indicators

1 LED flashing at one-second intervals  
START/TEST push button as manual override, to initiate a single pulse and to set the timer to zero

##### Mains supply

220 V, 50...100 Hz, 3.5 VA (other voltages on request)

##### Protection

IP 40

IP 65 (PRS-7b in sheet-steel case)

##### Permissible ambient temperature

0...55 °C

0...70 °C (PRS-7b in sheet-steel case)

##### Sheet-steel case

grey hammertone finish,  
2 cable glands Pg 11

##### Approx. weight

sheet-steel case included

1.4 kg

#### Three-Way Solenoid Valve

##### Connection

¼", BSP (DIN 259)

##### Max. service pressure

16 barg (230 psig)

##### Min. differential pressure required for opening and closing

0.5 bar (7.2 psi)

##### Duty cycle

100 %

##### Position of installation

as required, code letters for connections:

P = Pressure connection

A = Valve outlet

R = Exhaust or drain outlet

##### Mains supply

220 V, 50 Hz, 15 VA, inrush 30 VA

(other voltages and frequencies on request)

##### Protection

IP 65

##### Permissible ambient temperature

55 °C

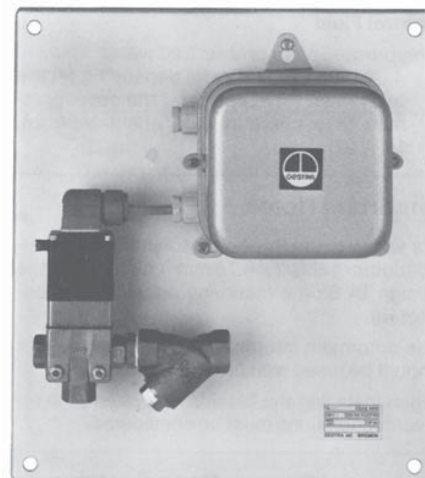
##### Approx. weight

0.9 kg

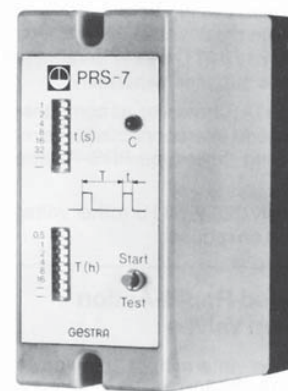
## Product Range A3

### TA 5

### TA 6



Programme-controlled blowdown system TA 6 on a mounting panel



Cycling timer PRS-7b as plug-in unit in plastic case

## Technical Data continued

### Strainer

#### Connection

½" BSP (DIN 259)

#### Material

Body: gun metal Rg 5  
Filter cartridge: ss 1.4571

#### Mesh size

0.5 mm

#### Approx. weight

0.3 kg

### Control Fluid

Compressed air or pressurized water, 4...8 barg (58...116 psig) depending on the blowdown valve used and the boiler pressure (see chart in data sheet MPA 26, MPA 27).

### Important Notes

For wiring to the three-way solenoid valve two-conductor cable 2 x 0.75 mm<sup>2</sup> can be used (the design TA 6 on a mounting panel is interconnected).

The automatic intermittent blowdown control should be fused with 2.5 A (inert fuse).

When installing the blowdown system, the relevant regulations must be considered.

### Order and Enquiry Specifications

GESTRA programme-controlled blowdown system with the GESTRA rapid-action intermittent blowdown valve, control fluid compressed air or pressurized water:

Type TA 5 with cycling timer type PRS 7-b as plug-in unit in plastic case, ¼" three-way solenoid valve type 340 C and ½" strainer, all component parts supplied separately.

Type TA 6 as TA 5, however, all component parts assembled and interconnected on a mounting panel, cycling timer type PRS-7b in a sheet-steel case.

Mains supply 220 V, 50 Hz (other voltages and frequencies on request).

### Associated Rapid-Action Blowdown Valves

Rapid-action intermittent blowdown valve type MPA 26 (PN 40) or MPA 27 (PN 63).

## Installation and Service Instructions

### Installation

Design TA 5: mount and interconnect component parts at the place of installation; the max. ambient temperature must not exceed 55 °C.

Connect outlet port of strainer to pressure connection of three-way solenoid valve using a reducer (strainer side screwed ½" BSP, solenoid valve side screwed ¼" BSP).

Connect control-fluid line (compressed air or pressurized water) to inlet port of strainer screwed ½" BSP.

Use a pipe 10 x 1 mm as control line leading to the rapid-action blowdown valve, connect to connection A of solenoid valve.

If pressurized water is used as control fluid, connect a drain line to connection R of the solenoid valve (screwed ⅜" BSP) with an inside diameter of approx. 12 mm, so that the water is immediately discharged without banking-up and the blowdown valve closed rapidly.

### Note

For the installation of the rapid-action blowdown valve see "Installation Instructions MPA 26, MPA 27".

## Wiring

Wiring should be carried out in accordance with wiring diagram (see last page).

In the case of the PRS-7b remove cable entries in the base to introduce cable. After wiring replace cover and tighten screws.

### Adjustment of Interval Time T (Blowdown Interval)

#### Example

Requested interval time T = 3.5 h

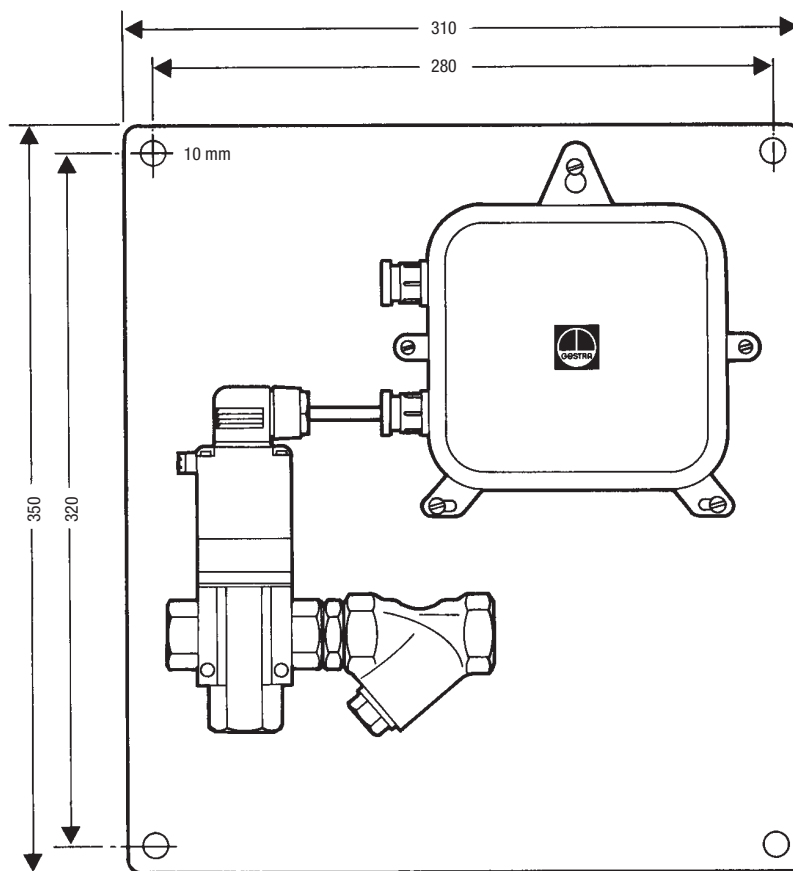
$$\begin{array}{r} 0.5 \\ 1 \\ \hline 2 \\ = 3.5 \text{ h} \end{array}$$

Move the 0.5, 1 and 2 (h) switches on the front panel to the left using a small screwdriver.

### Adjustment of Pulse Duration t (Blowdown Duration)

The pulse duration is set at our works to 2 seconds for effective blowdown and to avoid blowdown wastage. Before extending the pulse (blowdown) duration t it is essential to check whether longer blowdown durations are allowable for the boiler (lowering of water level, overheating of water-tube boilers etc.).

## Dimensions



Programme-controlled blowdown system type TA 6 with cycling timer type PRS-7b in sheet-steel case, three-way solenoid valve and strainer on a mounting panel.

## Commissioning

After switching on mains voltage, the system is ready for operation. This is indicated by flashing of the light-emitting diode on the PRS-7b. Push button START/TEST on the PRS-7b. This will initiate a single pulse. The next pulse is then released after the adjusted interval time T.

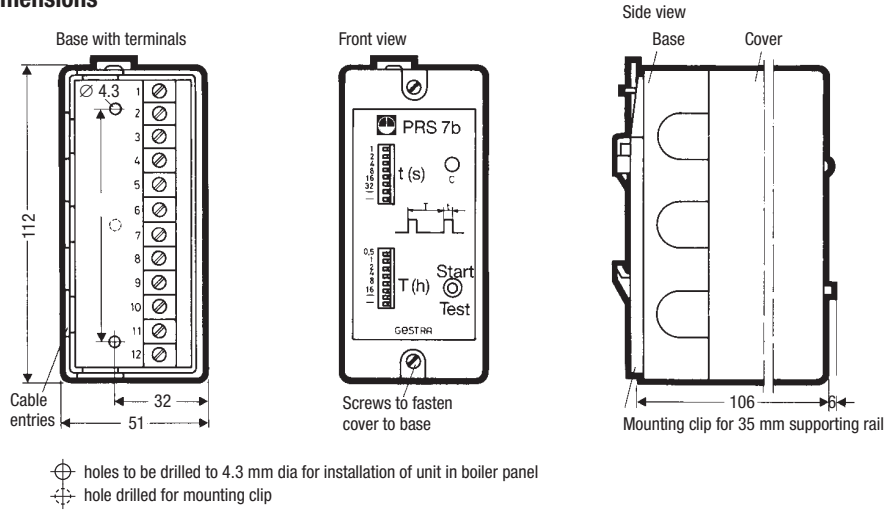
By pushing the button START/TEST on the PRS-7b a pulse can be initiated at any time during operation.

## Performance Test

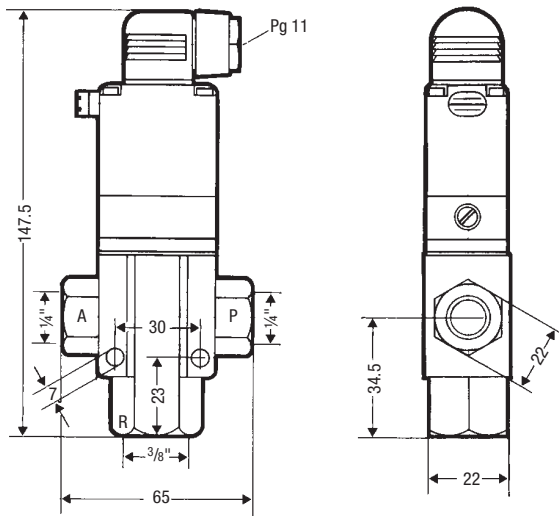
When pushing the button START/TEST on the PRS-7b, the rapid-action blowdown valve should open and close easily, otherwise clean filter or eliminate any other possible flow resistance.

For monitoring purposes or in the event of a power failure, the rapid-action blowdown valve can be actuated manually with the button provided on the three-way solenoid valve.

## Dimensions



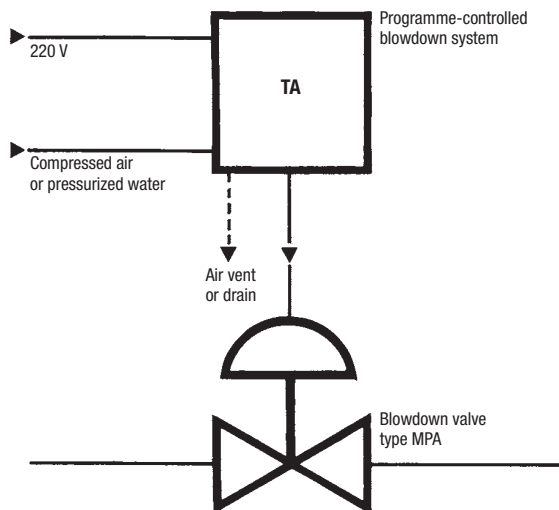
*Cycling timer type PRS-7b as plug-in unit in plastic case, component part of programme-controlled blowdown system type TA 5*



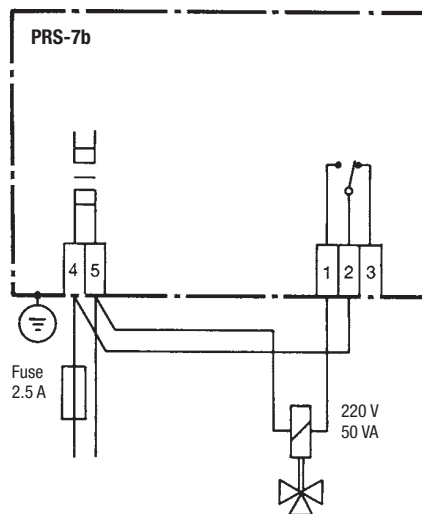
*Three-way solenoid valve type 340 C, 1/4", component part of programme-controlled blowdown systems types TA 5, TA 4*

Programme-Controlled  
Blowdown System  
TA 5, TA 6

Schematic Lay-out



Wiring Diagram



Cycling timer type PRS-7b in sheet-steel case,  
for programme-controlled blowdown systems types TA 5, TA 6

Supply in accordance with our general terms  
of business.

**Flowserve GESTRA U.S.**

2341 Ampere Drive  
Louisville, KY 40299  
Tel.: 001502 / 2672205, 001502 / 2672206  
Fax: 001502 / 2665397  
Email: dgoodwin@flowserve.com



GESTRA

## GESTRA Steam Systems

Product Range A3

### Blowdown System TA 7

TA 7

#### Purpose and Application

Electronic unit for the generation of periodic pulses to initiate a blowdown cycle via the GESTRA rapid-action intermittent blowdown valve type MPA, i.e. automation of intermittent boiler blowdown.

The equipment meets the German regulations for use in steam-boiler plants operating without constant supervision or with limited supervision (TRD 604 and TRD 602).

#### Design

The programme-controlled blowdown system consists of an electronic cycling timer, a three-way solenoid valve and a strainer.

The cycling timer is mounted in an appliance plug socket fitted on the three-way solenoid valve.

#### Operation

The cycling timer type PRS 8 generates a control pulse which, after the preset blowdown interval, operates the three-way solenoid valve. This in turn actuates the rapid-action blowdown valve by means of compressed air or pressurized water and closes it again at the end of the pulse (blowdown) duration.

The blowdown interval and the pulse duration can be coarsely preset with a dip switch. Final adjustment is carried out with the aid of two potentiometers.

For test purposes and in the event of a mains failure the three-way solenoid valve can be operated by hand. A push-button manual override is provided on the solenoid valve which allows a test of the blowdown valve as required by certain regulations in force.

#### Technical Data

##### Cycling Timer PRS 8

**Interval time  $t_{off}$**  (blowdown interval)  
Adjustable within a range of 0.5 to 10 h

**Pulse duration  $t_{on}$**  (blowdown duration)  
Adjustable within a range of 0.5 to 10 s

##### Indicators

One LED mains supply  
One LED pulse duration

##### Mains supply

115/230 V  $\pm$  10 %, 50/60 Hz  
(other voltages on request)

##### Protection

IP 65

##### Permissible ambient temperature

0 °C to 60 °C

##### Cable entry

PG cable gland for 0.6 to 7 mm cable

##### Approx. weight

60 g

##### Three-Way Solenoid Valve 340 C

##### Connection

1/4" BSP

##### Max. service pressure

16 barg (230 psig)

##### Min. differential pressure required for opening and closing

0.5 bar (7.2 psi)

##### Duty cycle

100%

##### Position of installation

as required

##### Code letters for connections

P = Pressure connection  
A/B = Valve outlet  
R = Exhaust or drain outlet

##### Mains supply

115/230 V  $\pm$  10 %, 50/60 Hz, 15 VA, inrush 30 VA  
(other voltages on request)

##### Protection

IP 65

##### Maximum permissible ambient temperature

55 °C

##### Approx. weight

0.9 kg

##### Strainer

##### Connection

1/2" BSP

##### Material

Body: gun metal RG 5  
Filter cartridge: austenitic stainless steel  
1.4571

##### Mesh size

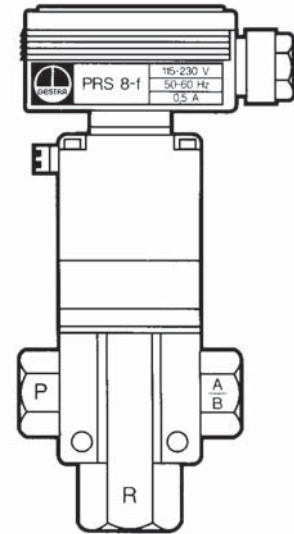
0.5 mm

##### Approx. weight

0.3 kg

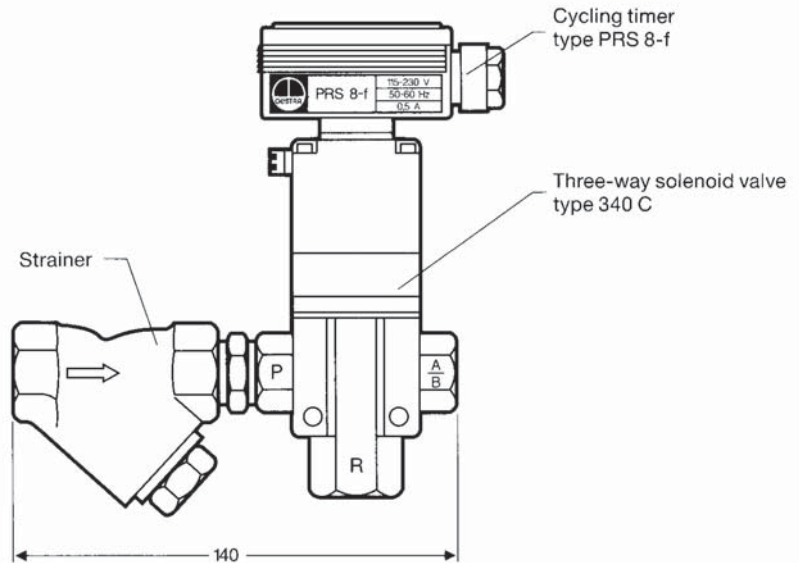
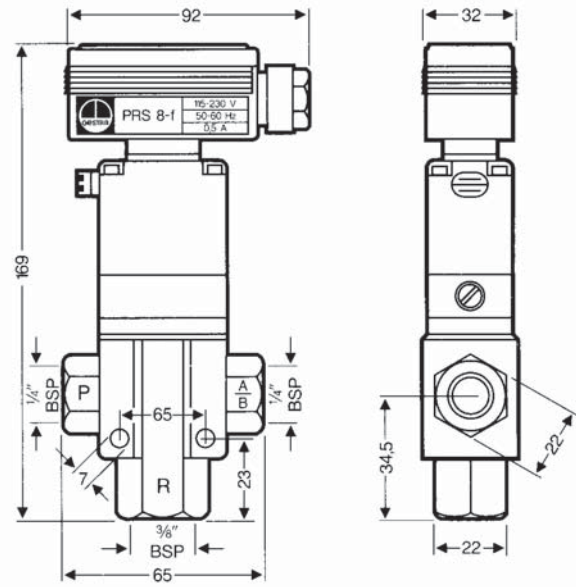
##### Control Fluid

Compressed air or pressurized water, 4 to 8 barg (58 to 116 psig) depending on the blowdown valve used and the boiler pressure (see chart in data sheet MPA 26, MPA 27)



Blowdown System  
TA 7

Dimensions



Dimensions of programme-controlled intermittent blowdown system

**Important Notes**

For wiring to the cycling timer three-core cable, conductor size 1.5 mm<sup>2</sup>, is required.

**Order and Enquiry Specifications**

GESTRA programme-controlled blowdown system type TA 7 with cycling timer type PRS 8, three-way solenoid valve type 340 C and strainer.

Supply in accordance with our general terms of business.

**Flowserve GESTRA U.S.**

2341 Ampere Drive  
Louisville, KY 40299  
Tel.: 001502 / 2672205, 001502 / 2672206  
Fax: 001502 / 2665397  
Email: dgoodwin@flowserve.com



GESTRA



## GESTRA Steam Systems

### Control Terminal and Display Unit Type URB 1

#### CANopen

#### System Description

The URB 1 is a user-friendly control terminal and display unit for use with GESTRA CAN bus systems. With the URB 1 all standard functions of the CAN bus systems can be easily called up and adjusted. The URB 1 uses the CANopen protocol.

Furthermore, the URB 1 makes the parameterization of the controller very convenient: The switchpoints, the response sensitivity and the proportional band can be adjusted by means of the keypad regardless of the actual values (level, conductivity). The energizing and deenergizing times of the relays can be customized for the switchpoints.

The URB 1 features a continuous display and therefore meets the requirements of TRD 401 / EN 12952 and EN 12953 for a second water level indicator. The equipment has also a temperature-compensated conductivity indication as required by VdTÜV – Bulletin WÜ 100 (Water Level 100).

The equipment indicates also malfunctions such as faulty electrode, excessively high temperature in a sensor, ambient temperature above max. limit, faulty communication etc.

The following tables specify the GESTRA equipment that can be displayed by the URB 1:

Standard display information	Level					Conductivity
	NRS 1-40	NRS 1-41	NRS 1-42	NRS 2-40	NRR 2-40	LRR 1-40
Actual value (bar chart)				●	●	●
Actual value (numerical value)				●	●	●
Switchpoint (symbol)			●	●	●	●
High level alarm (electrode HW)			●	●	●	●
Low level alarm (electrode LW)			●	●	●	●
Manual/automatic operation				●	●	●
Stand-by mode						●
Unit [ $\mu\text{S}/\text{cm}$ ] or [ppm]						●
Low level limit	●					
High level limit		●				
Alarm (warning triangle) ⚠	●	●				

Further display information	Level					Conductivity
	NRS 1-40	NRS 1-41	NRS 1-42	NRS 2-40	NRR 2-40	LRR 1-40
Actual value (continuous)				●	●	●
Switchpoints			●	●	●	●
Setpoint					●	●
Deviation					●	●
Valve position					●	●
Intermittent blowdown						●
Intermittent blowdown interval						●
Purging pulse 24 h						●
Current CAN bus addresses	●	●	●	●	●	●

#### Important Note

Note that screened multi-core twisted-pair control cable is required for the BUS line, e. g. UNITRONIC® BUS CAN 2 x 2 x ... mm<sup>2</sup> oder RE-2YCYV-fl 2 x 2 x ... mm<sup>2</sup>.

The baud rate (data transfer rate) dictates the cable length between the bus nodes and the total power consumption of the sensor dictates the conductor size.

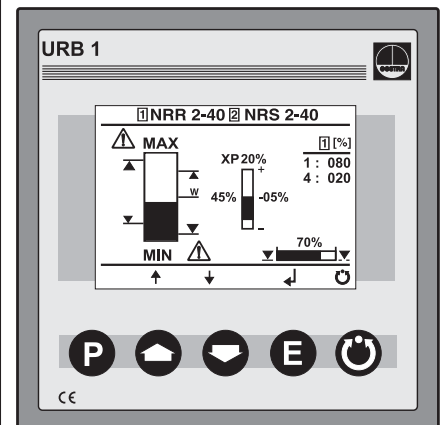
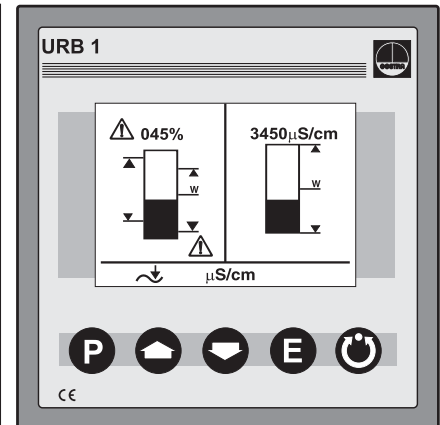
S 8	S 9	S 10	Baud rate	Cable length	Number of pairs and conductor size [mm <sup>2</sup> ]
OFF	ON	OFF	250 kBit/s	125 m	2 x 2 x 0.34
<b>Factory setting</b>					
ON	ON	OFF	125 kBit/s	250 m	2 x 2 x 0.5
OFF	OFF	ON	100 kBit/s	335 m	2 x 2 x 0.75
ON	OFF	ON	50 kBit/s	500 m	on request, dependent on bus configuration
OFF	ON	ON	20 kBit/s	1000 m	
ON	ON	ON	10 kBit/s	1000 m	

The baud rate is set via a code switch. Reduce baud rate if cable is longer than specified in the table. Make sure that all bus nodes have the same settings. To protect the switching contacts fuse circuit with 2.5 A (anti-surge fuse) or according to TRD regulations (1.0 A for 72 hrs operation).

**Note: If the cable is longer than 125 m (max. 1000 m!) the baud rate must be changed.**

## Product Range B

### URB 1



Example:  
Visual display of level monitoring system NRR 2-40

# Control Terminal and Display Unit Type URB 1 CANopen

## Function

The URB 1 communicates with other GESTRA systems via a CAN bus to DIN ISO 11898 using CANopen protocol.

## Design

### URB 1

Case according to DIN ISO 43700 for panel mounting. The terminals are accessible from the back. Installation in panel cut-out by means of fixing clips supplied with the equipment. Dimensions of panel cut-out: 92<sup>+0.8</sup> mm x 92<sup>+0.8</sup> mm.

## CAN Bus

All level and temperature switches, controllers and electrodes are interconnected by means of a CAN bus. The data exchange is effected by means of a CAN bus according to DIN ISO 11898 using the CANopen protocol. Every item of equipment features an electronic address (Node ID). The four-core bus cable serves as power supply and data highway for high-speed data exchange.

URB 1 is configured at our works and ready for service with other GESTRA components.

URB 1 can be used straight away without having to set the Node ID.

## Technical Data

**Type approval no.**  
TUV · WÜL · 02-007  
BAF-MUC 0205 103881 003

**Data exchange**  
CAN bus to DIN ISO 11898  
CANopen protocol

**Indicators and adjustors**  
1 illuminated display, resolution: 128 x 64 pixels  
5 push buttons

**Supply voltage**  
18 V – 36 V DC

**Protection**  
Front panel: IP 54 to DIN EN 60529  
Back: IP 00 to DIN EN 60529

**Admissible ambient temperature**  
0 °C – 55 °C

**Case material**  
Front face: Aluminium with polyester membrane  
Back: Noryl GFN 2 SE 1, glass-fibre reinforced

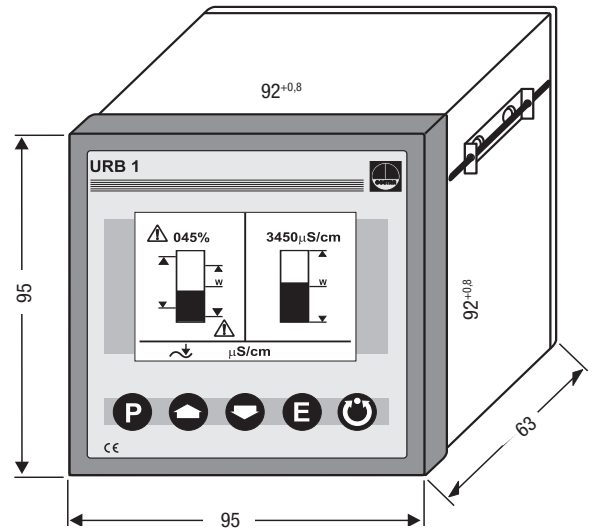
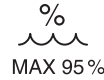
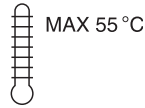
**Weight**  
Approx. 0.3 kg

## Order and Enquiry Specification

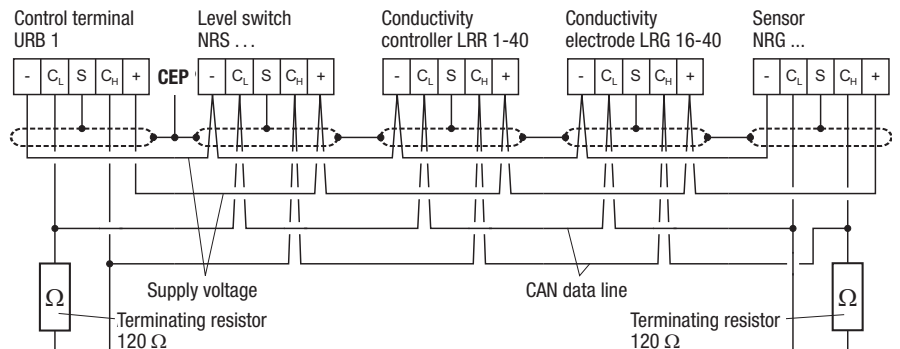
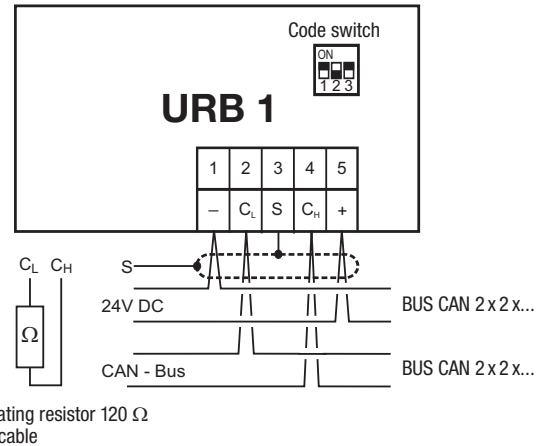
GESTRA Control terminal and display unit type URB 1 CANopen.

Supply in accordance with our general terms of business.

## Dimensions



## Wiring Diagram



# Flowserve GESTRA U.S.

2341 Ampere Drive  
Louisville, KY 40299  
Tel.: 001502 / 2672205, 001502 / 2672206  
Fax: 001502 / 2665397  
Email: dgoodwin@flowserve.com



GESTRA

## GESTRA Steam Systems

Product Range B2

### Power Supply Unit URN 2

### URN 2

#### Purpose and Application

The power supply unit type URN 2 in combination with up to four level switches and the cycling timer can be used as part of a controlled drainage system in power stations or for low level indication.

#### Example of installation

Use the PSU type URN 2 only for the power supply of a maximum of four level switches type NRS 2-4 or NRS 2-5 and the cycling timer type PRS 9.

#### Design

##### Design "c"

19" slide-in unit with guide rails and 32pole screw-type connector for installation in 19" magazine acc. to DIN 41494, part 5.

##### Design "d"

19" spare slide-in unit

#### Function

The mains voltage is stepped down, rectified and provided as 24 V DC supply voltage to the level switches NRS 2-4, NRS 2-5 and the cycling timer PRS 9.

#### Technical Data

##### Mains voltage

115/230 V ± 10 %, 50/60 Hz  
24 V ± 10 %, 50/60 Hz (option)

##### Power consumption

10 VA

##### Output

5 x 24 V DC

##### Indicator and adjustor

1 green LED OPERATION

##### Protection

IP 10 to DIN 40050

##### Admissible ambient temperature

0 °C to + 70 °C

##### Case

19" slide-in unit with front panel to DIN 41494 part 5 and rear 32 way Euro card connector to DIN 41612 for installation onto 19" mounting panels.

Front panel: Aluminium.

##### Wiring

via 32pole screw-type connector at the rear of the 19" magazine; max. conductor size 1.5 mm<sup>2</sup>

##### Internal fuse

Glass cartridge fine-wire slow-blow fuse  
500 mA, replaceable

##### Weight

approx. 0.6 kg

#### Scope of supply

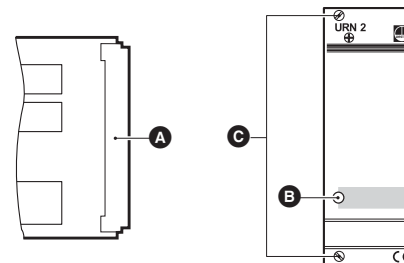
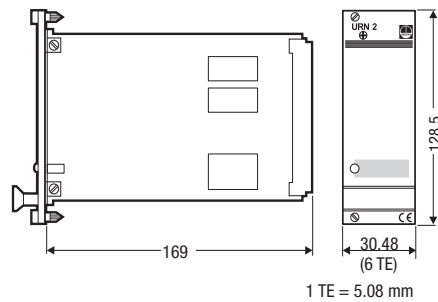
##### URN 2, design "c"

- 1 Power supply unit type URN 2
- 2 Guide rails
- 1 32pole screw-type connector
- 1 Installation instructions

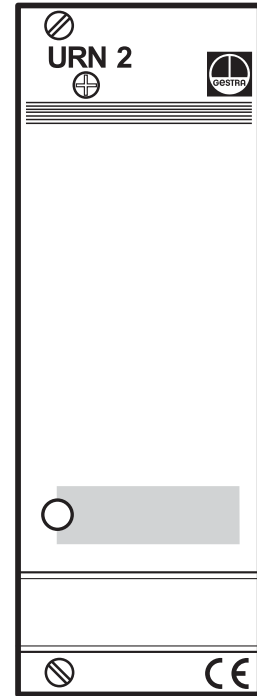
##### URN 2, design "d"

- 1 Power supply unit type URN 2
- 1 Installation instructions

#### Dimensions



- A** 32pole screw-type connector
- B** LED SERVICE
- C** Fixing screws




Power supply unit URN 2

## Power Supply Unit URN 2

### Installation

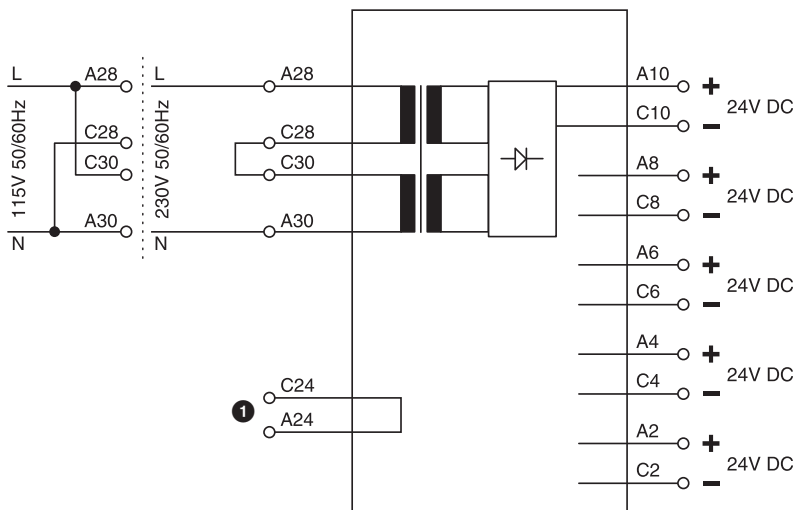
#### Design "c"/"d"

- Install the guide rails and the screw-type connector in the 19" magazine.
- Introduce the 19" slide-in unit onto the guide rails until it hits the stop.
- Tighten the fixing screws .

### Wiring diagram

#### Design "c"/"d"

Wiring is effected via the 32pole screw-type connector.



1 Test loop

Supply in accordance with our general terms of business.

## Flowserve GESTRA U.S.

2341 Ampere Drive  
Louisville, KY 40299  
Tel.: 001502 / 2672205, 001502 / 2672206  
Fax: 001502 / 2665397  
Email: dgoodwin@flowserve.com

**FLOWSERVE**<sup>®</sup>

GESTRA

## GESTRA Steam Systems

Product Range B2

### Max.-Min. Limit Switch URS 2b

### URS 2

#### Purpose and Application

Universal signalling of 2 limit values as MAX and MIN alarm. Connection to a measuring transducer with current output 0 to 20 mA or 4 to 20 mA.

Application, for example, with the GESTRA level transmitter type NRT 2-1b, the continuous blowdown controller type LRR 1-5b and the conductivity transmitter type LRT 1-5b or LRT 1-6b.

#### Design

Plug-in unit in plastic case for installation in control cabinets. The terminals in the case are accessible after loosening two screws and unplugging the unit from its base. To avoid confusion with other plug-in units of the GESTRA range, inserts are fitted in the bases so that only the correct unit may be plugged into each base.

The plug-in units may be snapped onto a 35 mm supporting rail or screwed into position on a mounting panel.

Field enclosures for several plug-in units are available on request.

#### Technical Data

##### Function

Limit alarm with one MAX and one MIN contact for wiring to a measuring transducer with current output 0 . . . 20 mA or 4 . . . 20 mA

##### Input

for measuring transducer with current output 0 . . . 20 mA (or 4 . . . 20 mA after establishing a wire link), input resistance 100 Ω

##### Output

2 potential-free relay contacts,  
max. contact rating: 250 V, 500 W, 3 A  
ohmic with a life of  $4 \times 10^5$  switching  
cycles or 0.35 A inductive with a life of  
 $2 \times 10^6$  cycles;  
contact material silver, hard-gold plated

##### Switching hysteresis

1%

##### Adjustors

2 adjustors provided with a scale  
0 . . . 100% for MAX and MIN alarm, con-  
tinuously adjustable

##### Indicators

1 LED for MAX alarm, 1 LED for MIN alarm

##### Mains supply

24 V, 110 V, 120 V, 220 V, 240 V,  
50 . . . 100 Hz, 3.5 VA  
(please state voltage when ordering),  
24 VDC supply also possible with the  
ancillary unit type URN-1

Protection  
IP 40

Permissible ambient temperature  
0 . . . 50 °C

##### Case materials

Base: ABS plastic, black  
Cover: polystyrene (highly shock-resis-  
tant), stone grey

Approx. weight  
0.5 kg

#### Important Notes

The max.-min. limit switch type URS 2b can be used with any measuring transducer having a current output 0 to 20 mA. For GESTRA measuring transducers see under "Associated Equipment".

#### Order and Enquiry Specifications

GESTRA max.-min. limit switch for 2 limit values used with a measuring transducer provided with current output:

Max.-min. limit switch type URS 2b, plug-in unit in plastic case for installation in control cabinets

Mains supply . . . V

#### Associated Equipment

Level transmitter type NRT 2-1b for on-off level control

Continuous blowdown controller type LRR 1-5b for TDS control

Conductivity transmitter type LRT 1-5b or LRT 1-6b for conductivity monitoring of li-  
quids



Max.-min. limit switch URS 2b

## Max.-Min. Limit Switch URS 2b

### Installation and Service Instructions

#### Installation

##### 1. With mounting clip

Snap unit onto 35 mm supporting rail.

##### 2. Without mounting clip

Loosen cover screws and unplug unit from its base. Unscrew mounting clip. Drill the holes in the base marked  $\varnothing$  4.3 mm. Fasten base with two screws M 4 onto mounting panel.

#### Wiring

Wiring should be carried out in accordance with wiring diagram (see diagram opposite or inside cover of plug-in unit). The mains voltage is indicated on the name plate.

To introduce cable, remove cable entries in the base. After wiring replace cover and tighten screws.

##### Wiring to the measuring transducer

Measuring transducers with current output 0 to 20 mA can be wired directly.

For measuring transducers with output 4 to 20 mA, link terminals 10 and 11.

##### Wiring to signalling equipment

Take care of max. contact rating indicated.

#### Performance Tests

If the input signal is lower than the set MIN switchpoint, lamp  $\odot$  must light up. The MIN contact should be in the position shown in the wiring diagram.

If the input signal exceeds the set MAX switchpoint, lamp  $\odot$  must light up. The MAX contact should be in the position shown in the wiring diagram.

NOTE: Before unplugging cover of URS 2 cut off power.

#### Relay Arc Suppression for Inductive Loads

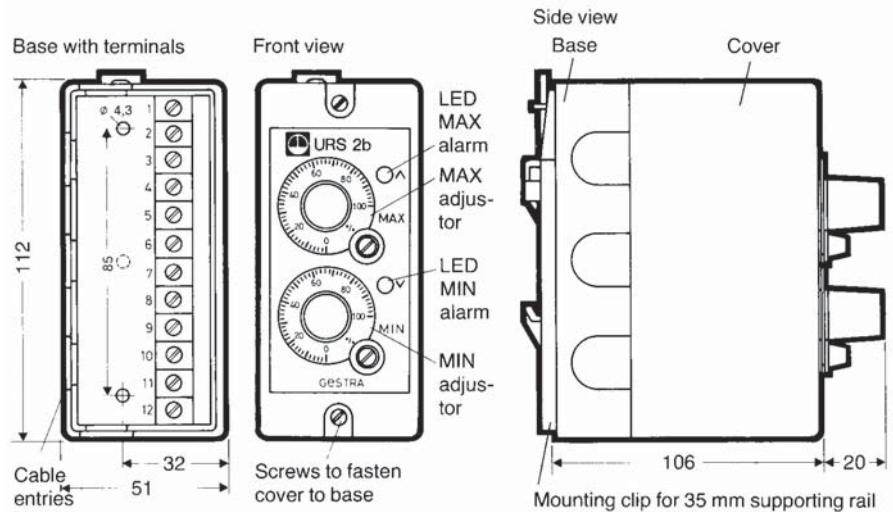
When switching off inductive loads voltage peaks are produced that may reach several times the mains voltage. The result is:

1. The operation of control and measuring systems may be impaired by interference caused by the voltage peaks.
2. The life of the relay contacts is reduced by the electric arcs formed.

We therefore recommend that inductive loads are provided with commercial arc suppressor RC combinations (e.g. 0.1  $\mu$ F/100  $\Omega$ ).

Supply in accordance with our general terms of business.

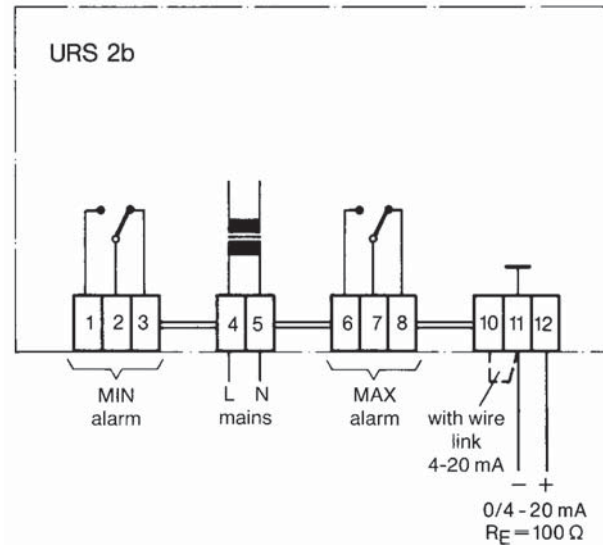
#### Dimensions



- $\varnothing$  holes to be drilled to 4.3 mm dia for installation of unit in boiler panel
- $\oplus$  hole drilled for mounting clip

Dimensions of max.-min. limit switch type URS 2b

#### Wiring Diagram



Wiring diagram for max.-min. limit switch type URS 2b, drawn position of contacts: relays deenergized, i.e. alarm

## Flowserve GESTRA U.S.

2341 Ampere Drive  
Louisville, KY 40299  
Tel.: 001502 / 2672205, 001502 / 2672206  
Fax: 001502 / 2665397  
Email: dgoodwin@flowserve.com



GESTRA

## Product Index

AK 45	103	LRGT 16-1	219
BA 28, BA 29, BA 210, BA 211	257	LRR 1-40	237
BA(E) ASME 46, BA(E) ASME 47	251	LRS 1-5b, LRR 1-6b	229
BK 15	55	LRT 1-5b, LRT 1-6b	235
BK 212	49	MB 26a	113
BK 212EX	53	MK 25/2	27
BK 212HT	51	MK 25/2S	29
BK 27	57	MK 35/2S	23
BK 28	45	MK 35/2S3	25
BK 29	47	MK 35/31	13
BK 36/A7	37	MK 35/32	15
BK 37	43	MK 36/51, MK 36/52	17
BK 45	39	MK 36/A7	11
BK 46	41	MK 45/1	19
CB 14	131	MK 45/2	21
CB 24S, CB 26, CB26A	133	NRG 16-11, NRG 17-11, NRG 19-11	193
DK 36/A7	97	NRG 16-36	201
DK47	99	NRG 16-40, NRG 17-40, NRG 19-40	207
DK 57	101	NRG 16-41, NRG 17-41, NRG 19-41	205
FMAHC	153	NRG 16-42	167
FMAHS	155	NRG 211	209
FMAVC	149	NRG 21-11, NRG 21-51	185
FMAVS	151	NRG 26-21	187
FPS-11	137	NRG 26-40	179
FPS-14	139	NRGS 11-1, NRGS 16-1, NRGS 16-1S	161
FPS-24	141	NRGS 11-2, NRGS 16-2	163
FPS-33L	141	NRGS 15-1	165
GK 11/21	107	NRGT 26-1, NRGT 26-1S	175
KS 92-1	269	NRR 2-40	183
LRG 12-1	233	NRS 1-3	171
LRG 12-2	231	NRS 1-5	173
LRG 16	223	NRS 1-7	197
LRG 16-40	221	NRS 1-8	199
LRG 17, LRG 19	227	NRS 1-9	203

## *Index (Continued)*

NRS 1-40	215	UNA 39	87
NRS 1-41	217	UNA SPECIAL, PN 25	73, 91, 93
NRS 1-42	169	UNA SPECIAL, PN 63	95
NRS 2-1	191	UNA SPECIAL, TYPE 62	71, 89
NRS 2-3	177	URB 1	281
NRS 2-4	211	URN 2	283
NRS 2-5	213	URS 2	285
NRS 2-40	181	V20	147
NRZ 2-1	189	ZK 29	239
ORGS 11-2	263	ZK 213	247
OR 52/5, OR 52/6	265	ZK 313	243
(M)PA 46, (M)PA 47, (M)PA 110	259		
RK 16	121		
RK 26A	123		
RK 41	117		
RK 44, RK 44S	119		
RK 49	129		
RK 70, RK 71	115		
RK 76	127		
RK 86, RK 86A	125		
SMK 22	105		
SRL 63-a	273		
TA 5, TA 6	275		
TA 7	279		
TK 23, TK 24 (2½", 3", 4")	33		
TK 23, TK 24 (2")	31		
UBK 46	109		
UNA 14, UNA 16	61		
UNA 14P	79		
UNA 14S, UNA 16S	77		
UNA 26H	63, 81		
UNA 26H MAX	65		
UNA 27H	67, 83		
UNA 38	69, 85		